

Warning Dual supply



NOTE

The label **MUST** be placed on the LCP frame as shown (UL-approved).

How to add the MCO 101 option:

- The power to the adjustable frequency drive must be disconnected.
- The power to the live part connections on relay terminals must be disconnected.
- Remove the LCP, the terminal cover and the cradle from the FC 202.
- Insert the MCO 101 option in slot B.
- Connect the control cables and secure the cables using the enclosed cable strips.
- Different systems cannot be combined.
- Install the extended cradle and terminal cover.
- Replace the LCP.
- Connect power to the adjustable frequency drive.

Wiring the Terminals

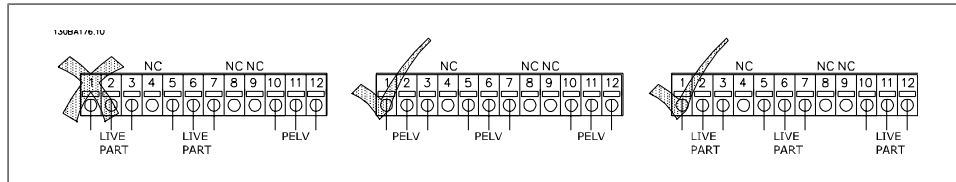
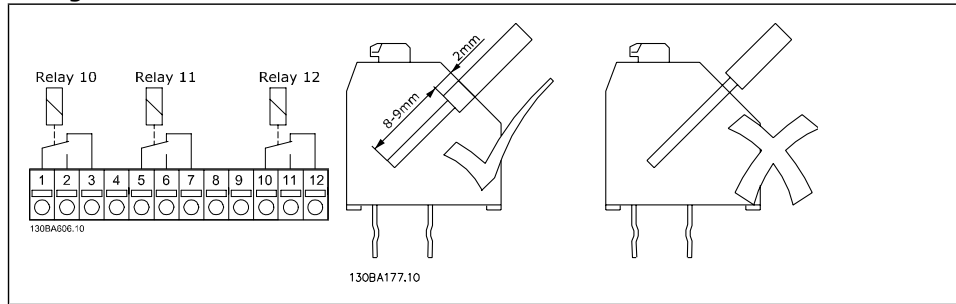

Do not combine low voltage parts and PELV systems.

3. Supported Configuration

3.1.1. Introduction

The extended cascade controller supports a variety of different pump and drive configurations. All of these configurations must have at least one variable speed pump, controlled by a VLT AQUA Drive and with the extended cascade controller option card installed. They must also have from one to five additional pumps, each connected to either a Danfoss VLT Drive or to line power through a contactor or soft starter.

3

3.1.2. Fixed-speed Pump Configuration

In this configuration, a single drive controls one variable speed pump and up to 5 fixed-speed pumps. The fixed-speed pumps are staged and de-staged as needed through contactors direct online. The single pump connected to the drive provides the finer level of control needed between the stages.

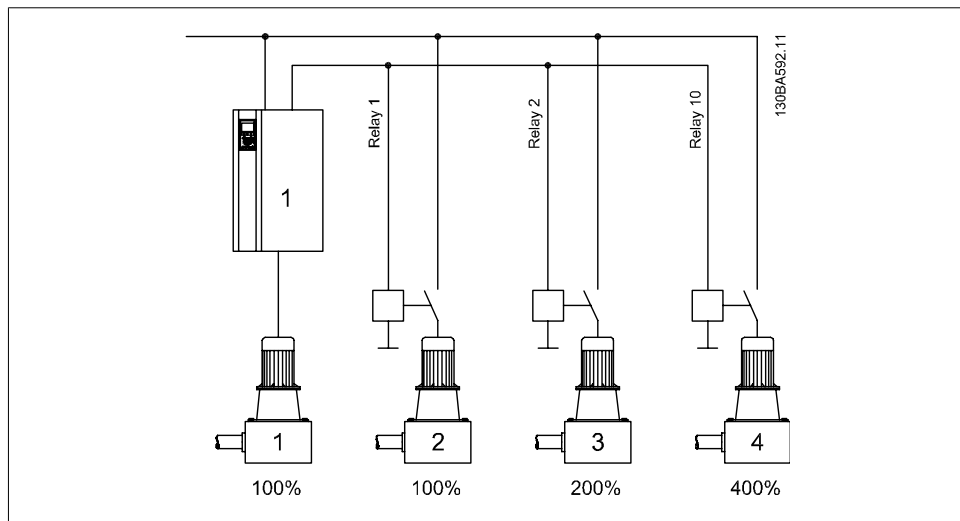

3.1: Example

For this configuration, relay selections in Group 27-7* "Connections" are as follows:

- 27-70 RELAY 1 → [73] Pump 2 to Line Voltage
- 27-71 RELAY 2 → [74] Pump 3 to Line Voltage
- 27-72 RELAY 10 → [75] Pump 4 to Line Voltage
- 27-73 RELAY 11 → [0] Standard Relay
- 27-74 RELAY 12 → [0] Standard Relay

The Fixed-speed Pump configuration provides a cost-effective method for controlling up to six pumps. It is able to control system output by controlling the number of running pumps as well as the speed of the single variable speed pump. It will however produce wider pressure fluctua-

tions during staging/de-staging transitions and it may be less energy efficient than the Master-Follower configurations.

3.1.3. Master-Follower Configuration

In this configuration, each pump is controlled by a drive. All of the pumps and drives must be of the same size. Staging and de-staging decisions are made based on the speed of the drives as well as the feedback sensor. Up to 6 pumps with drives can be part of this configuration.

3

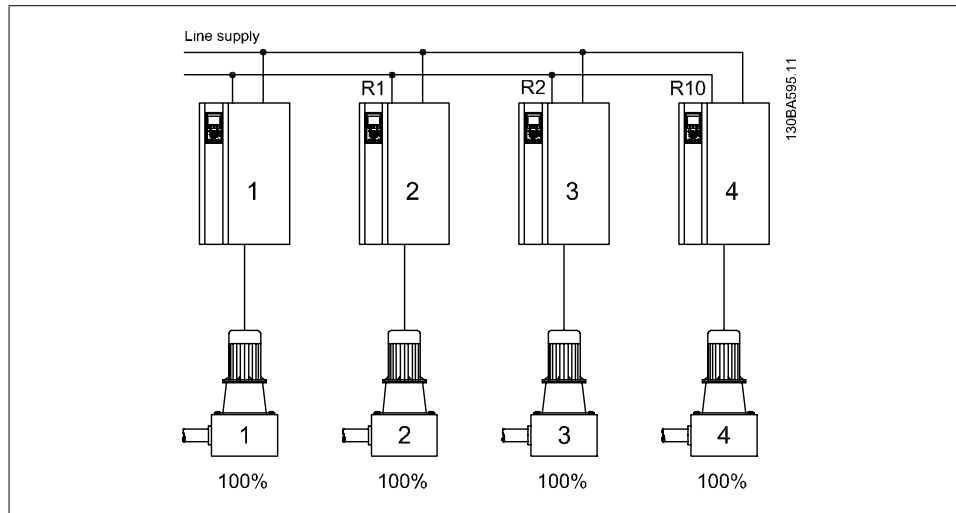

3.2: Example

For this configuration, relay selections in Group 27-7* "Connections" are as follows:

- 27-70 RELAY 1 → [1] Drive 2 Enable
- 27-71 RELAY 2 → [2] Drive 3 Enable
- 27-72 RELAY 10 → [3] Drive 4 Enable
- 27-73 RELAY 11 → [0] Standard Relay
- 27-74 RELAY 12 → [0] Standard Relay

The master/follower configuration provides the gentlest transition from one stage to the next and the most energy efficient operation. For most installations, the energy savings makes this the most cost-effective configuration.

3.1.4. Mixed Pump Configuration

The Mixed Pump configuration supports a mix of variable speed pumps connected to drives as well as additional fixed-speed pumps. In this configuration, all of the variable speed pumps and drives must be the same size. The fixed-speed pumps may be of different sizes. The variable speed pumps are staged on and staged off first based on drive speed. The fixed-speed pumps are then staged on last and staged off last based on the feedback pressure.

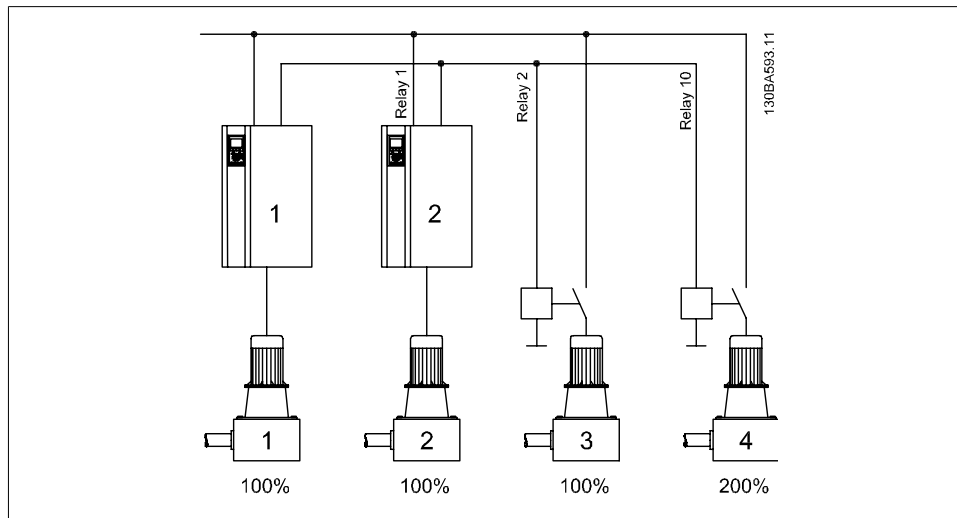

3.3: Example

For this configuration, relay selections in Group 27-7* "Connections" are as follows:

- 27-70 RELAY 1 → [1] Drive 2 Enable
- 27-71 RELAY 2 → [74] Pump 3 to Line Voltage
- 27-72 RELAY 10 → [75] Pump 4 to Line Voltage
- 27-73 RELAY 11 → [0] Standard Relay
- 27-74 RELAY 12 → [0] Standard Relay

This configuration provides some of the benefits of the Master-Follower configuration with some of the initial cost savings of the Fixed Speed configuration. It is a good choice when the extra capacity of the fixed pumps is rarely needed.

3.1.5. Unequal Size Pump Configuration

The Unequal Size Pump configuration supports a limited mix of fixed-speed pumps in different sizes. It provides for the largest range of system output with the smallest number of pumps.

3

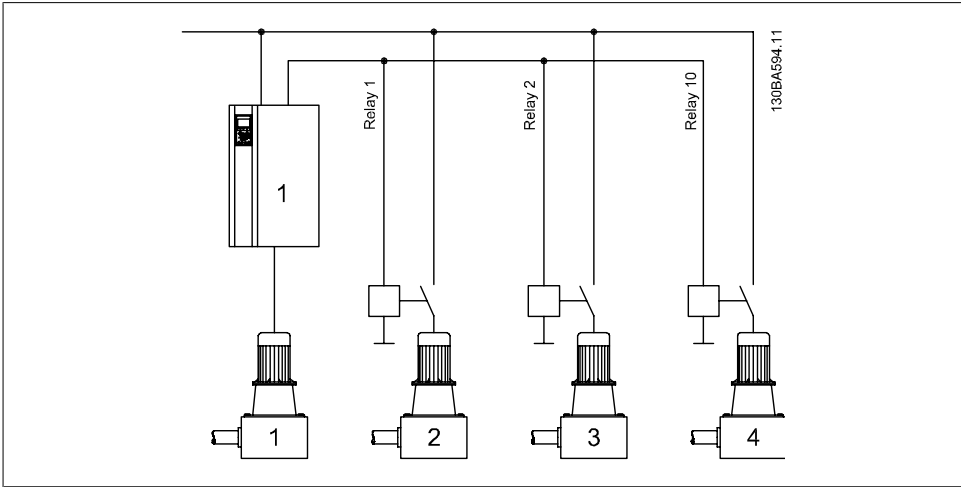

3.4: Example

For this configuration, relay selections in Group 27-7* "Connections" are as follows:

- 27-70 RELAY 1 → [73] Pump 2 to Line Voltage
- 27-71 RELAY 2 → [74] Pump 3 to Line Voltage
- 27-72 RELAY 10 → [75] Pump 4 to Line Voltage
- 27-73 RELAY 11→ [0] Standard Relay
- 27-74 RELAY 12→ [0] Standard Relay

Not all configurations of unequal size pumps are valid. For a configuration to be valid, it must be possible to stage pumps in increments of 100% of the size of the master drive's variable speed pump. This is necessary since the variable speed pump must be able to control the output between the fixed-speed stages.

Valid Configurations

100% is defined as the maximum flow produced by the pump connected to the master drive. The fixed-speed pumps must be multiples of this size.

Variable Speed	Fixed Speed
100%	100% + 200%
100%	100% + 200% + 200%
100%	100% + 100% + 300%
100%	100% + 100% + 300% + 300%
100%	100% + 200% + 400%
100% + 100%	200%
100% + 100%	200% + 200%

(Other valid configurations are possible)

Invalid Configurations

Invalid configurations will still run but will not stage on all of the pumps. This is done to allow for limited operation if a pump fails or is interlocked in this configuration.

Variable Speed	Fixed Speed	
100%	200%	(no control between 100% and 200%)
100%	100% + 300%	(no control between 200% and 300%)
100%	100% + 200% + 600%	(no control between 400% and 600%)

3.1.6. Mixed Pump Configuration with Alternation

In this configuration, it is possible to alternate the drive between two pumps along with controlling additional fixed-speed pumps. The cascade controller will attempt to balance the running hours between all of the pumps as specified by the Runtime Balancing parameter.

3

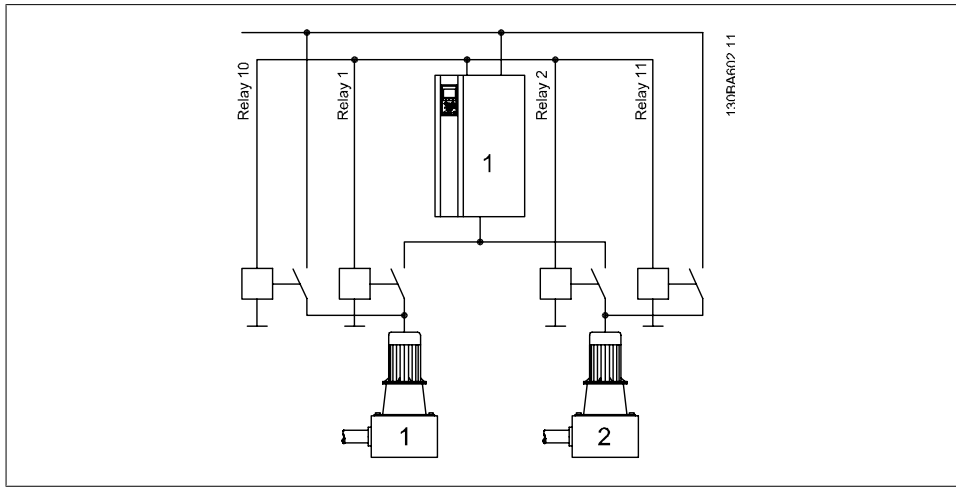

3.5: Example 1

The two pumps can be either variable speed or fixed-speed with equal running hours.

For this configuration, relay selections in Group 27-7* "Connections" are as follows:

- 27-70 RELAY 1 → [8] Pump 1 to Drive 1
- 27-71 RELAY 2 → [16] Pump 2 to Drive 1
- 27-72 RELAY 10 → [72] Pump 1 to Line Voltage
- 27-73 RELAY 11 → [73] Pump 2 to Line Voltage
- 27-74 RELAY 12 → [0] Standard Relay

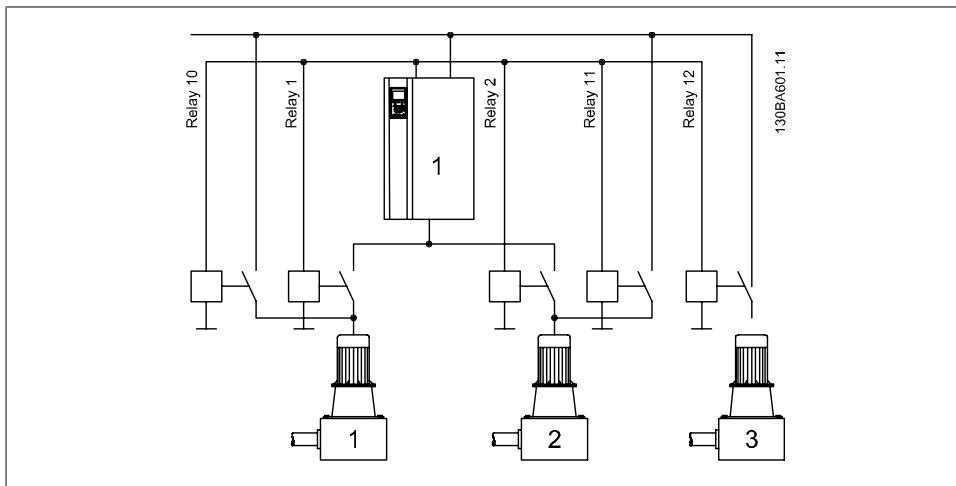

3.6: Example 2

The first two pumps can be either variable speed or fixed-speed with equal running hours between all three pumps as long as the system demand is typically greater than 1 pump.

For this configuration, relay selections in Group 27-7* "Connections" are as follows:

- 27-70 RELAY 1 → [8] Pump 1 to Drive 1
- 27-71 RELAY 2 → [16] Pump 2 to Drive 1
- 27-72 RELAY 10 → [72] Pump 1 to Line Voltage
- 27-73 RELAY 11 → [73] Pump 2 to Line Voltage
- 27-74 RELAY 12 → [74] Pump 3 to Line Voltage

3

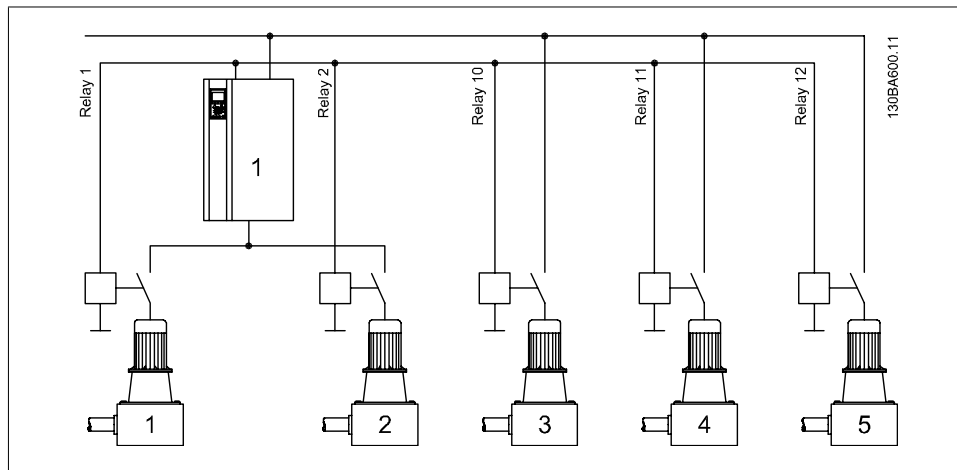

3.7: Example 3

The first two pumps alternate each with 50% of the running hours. The fixed-speed pumps turned on and off as needed with equal running time between them.

For this configuration, relay selections in Group 27-7* "Connections" are as follows:

- 27-70 RELAY 1 → [8] Pump 1 to Drive 1
- 27-71 RELAY 2 → [16] Pump 2 to Drive 1
- 27-72 RELAY 10 → [74] Pump 3 to Line Voltage
- 27-73 RELAY 11 → [75] Pump 4 to Line Voltage
- 27-74 RELAY 12 → [76] Pump 5 to Line Voltage

3.1.7. Soft Starters

Soft starters can be used in place of contactors for any configuration using fixed speed pumps. If soft starters are selected, they must be used for ALL fixed speed pumps. Mixing soft starters and contactors will result in an inability to control the output pressure during staging and de-staging transitions. When using soft starters, a delay will be added from when the staging signal occurs until staging takes place. The delay is necessary due to the ramp time of the fixed speed pump because of the soft starter.



4. Configuring the System

4.1.1. Introduction

The extended cascade controller can be quickly configured using many of the default parameters. However, it is first necessary to describe the configuration of drives and pumps in the system, and to describe the desired level of control of the system's output.

4.1.2. Defining the Hardware Configuration

Parameter groups 27-1* "Configuration" and 27-7* "Connections" are used to define the hardware configuration of the installation. Start the configuration of the cascade controller by selecting values for the parameters in the 27-1* "Configuration" group.

Parameter no.	Description
27-10	Cascade Controller can be used to enable or disable the extended cascade controller. The Mixed Pump selection is the general selection for the cascade controller. If using one drive per pump, the Master-Follower configuration can be selected reducing the number of parameters needed to set up the system.
27-11	Number of Drives
27-12	Number of Pumps - Will default to the Number of Drives.
27-14	Pump Capacity for each pump (Indexed Parameter) - If all of the pumps are the same size, the default values shall be used. To adjust: first choose the pump, click OK and adjust the capacity.
27-16	Runtime Balancing for each pump (Indexed Parameter) - If the system should balance the running hours equally between the pumps, then use the default values.
27-17	Motor Starters - All fixed-speed pumps must be the same.
27-18	Spin Time for Unused Pumps - Depends on the size of the pumps.

Next, the relays used to turn pumps on and off need to be defined. Parameter group 27-7* "Connections" provides a list of all of the available relays:

- Each follower drive in the system needs to have one relay assigned to enable/disable the drive as needed.
- Each fixed speed pump needs to have one relay assigned to control the contactor or enable the soft starter to turn the pump on/off.
- If it is necessary to have a single drive alternate between two pumps, then additional relays need to be assigned to provide this capability.

Any unused relays will be available for other functions through the 05-4* parameter group.

4.1.3. Additional Configuration for Multiple Drives

When more than one drive is used in the cascade controller, it is necessary for the master drive to tell the follower drives how fast to run. This is accomplished through a digital signal between the drives.

The master drive must use a digital output pin to output the required frequency for all of the drives. All of the drives always run at the same speed. Setting parameter 05-60 to [116] Cascade Reference will select pin 27 for this function.

Each of the follower drives must then be set to open-loop and must use a digital input as their speed reference. This can be done by setting parameter 01-00 Configuration Mode to [0] Open-loop and parameter 03-15 to selection [7] Frequency Input 29.

The 03-41 Ramp-up Time and 03-42 Ramp-down Time must be the same for the master drive and for all of the follower drives in the system.

These ramps should be set fast enough that the PID controller is able to maintain control of the system.

4

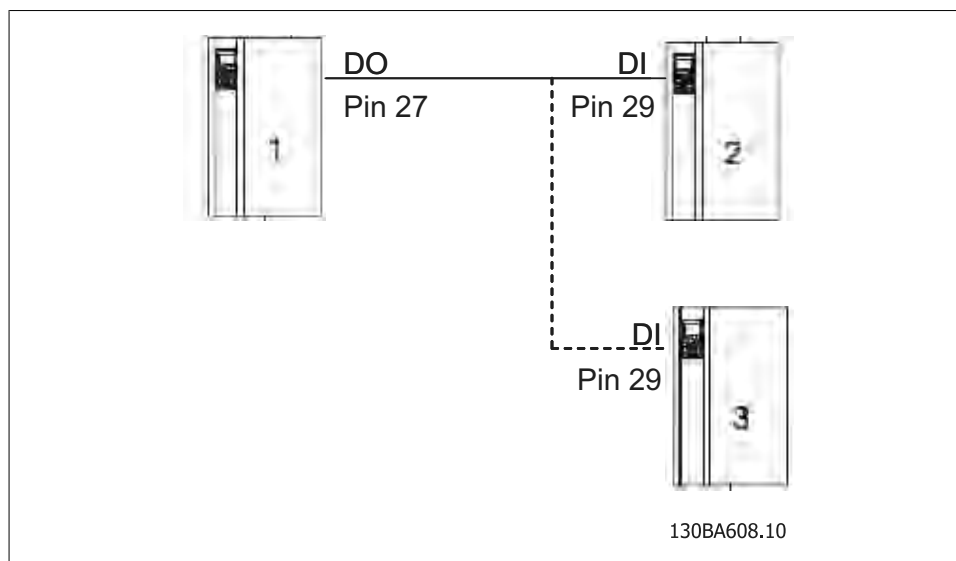

4.1.4. Closed-loop Control

The master drive is the primary controller for the system. It monitors the output pressure, adjusts the speed of the drives and decides when to add or remove stages. To perform this function, the master drive must be set up in closed-loop mode with a feedback sensor connected to an analog input on the drive.

The PID controller of the master drive must be set up to match the needs of the installation. Setting up the PID parameters is described in the VLT AQUA Drive Programming Guide and will not be covered in this manual.

4.1.5. Staging /de-staging variable speed pumps based on drive speed

In Master-Follower configurations and Mixed Pump configurations the variable speed pumps are staged and de-staged based on the speed of the drives.

Staging occurs when the speed of the drives has reached the value in parameter 27-31 (27-32) Stage on Speed. At this speed the system pressure is still maintained, but the pumps begin to operate outside of their peak efficiency points. Staging on an additional pump will lower the speed of all of the running pumps and provide a more energy efficient operation.

De-staging occurs when the speed of the drives drops below the value in parameter 27-33 (27-34) Stage Off Speed. At this speed the system pressure is still maintained, but the pumps begin to operate below their peak efficiency points. De-staging a pump will cause the speed of the drives to increase into a more energy efficient range.

Parameters 27-31 (27-32) Stage on Speed and 27-33 (27-34) Stage Off Speed are installation dependent. These parameters are indexed parameters with one set of entries for each pump stage.

Danfoss provides the Multiple Unit Staging Efficiency Calculator (MUSEC), a free software program available on the Danfoss website. By entering pump and system data, MUSEC provides the optimal settings for the Stage On and Stage Off speed parameters.

4.1.6. Staging/de-staging of fixed speed pumps based on pressure feedback

Fixed speed pumps are staged based on a drop in system pressure, and are de-staged based on an increases in system pressure.

Since it is undesirable to have pumps turning on and off rapidly, an acceptable range of system pressure needs to be defined along with a period of time the pressure is allowed to remain outside of this band before staging or de-staging occurs. These values are set through parameters 27-20 "Normal Operating Range" 27-23 "Staging Delay" and 27-24 "De-staging Delay".

These parameters are installation dependent and should be set to meet the requirements of the system.



5

5. Running the Extended Cascade Controller

5.1.1. Introduction

Once the cascade controller has been configured, it can be enabled or disabled through parameter 27-10 "Cascade Controller".

To start the cascade controller, the master drive needs to be started as a normal drive through the LCP or through serial bus communications. It will then attempt to control the system pressure by varying the speed of the drive and by staging on and off pumps as needed.

Two stop functions are provided by the cascade controller. One function quickly stops the system. The other stages off pumps in a sequence, allowing for a pressure controlled stop.

For a VLT AQUA Drive equipped with Safe Stop, Terminal 37 will turn off all relays and coast the master drive. If any of the digital inputs are set to [8] "Start" and the corresponding terminal is used to control the starting and stopping of the drive, setting the terminal to 0 volts will turn off all relays and coast the master drive. Pressing the OFF button on the LCP will cause a sequenced de-staging of all of the running pumps.



6

6. Cascade Controller Features

6.1.1. Pump Status and Control

The 27-0* group of parameters provides a convenient place to check on the status of the cascade controller and to control individual pumps. In this parameter group, it is possible to select a specific pump to view the current status, the current running hours, and the total lifetime hours. From the same location, an individual pump can be manually controlled for maintenance purposes.

The parameter group is organized as follows:

	Pump 1	Pump 2	Pump 3	Pump ...
27-01 Status	On Drive	Ready	Offline-off	
27-02 Control	No Operation	No Operation	No Operation	
27-03 Current Hrs	650	667	400	
27-04 Lifetime Hrs	52673	29345	30102	

Navigate to the 27-0* group on the LCP.
 Use the right and left arrows on the LCP to select the pump.
 Use the up and down arrows on the LCP to select the parameter.

6.1.2. Manual Pump Control

The extended cascade controller allows for complete control of each pump in the system. Using parameter 27-02, pumps can be individually controlled through their selected relays. A pump can be turned on or off outside of the control of the extended cascade controller or can be forced to alternate the lead.

This parameter is different than other value related parameters in that selecting one of these options will cause the action to occur and then the parameter will revert back to its default state.

The choices are as follows:

- No Operation - Default.
- Online - Makes the pump available to the extended cascade controller.
- Alternate On - Forces the selected pump to be the lead pump.
- Offline-Off - Turns the pump off and makes it unavailable for cascading.
- Offline-On - Turns the pump on and makes it unavailable for cascading.
- Offline-Spin - Initiates a pump spin.

If any of the "Offline" selections are chosen, the pump will no longer be available to the cascade controller until "Online" is selected.

If a pump is taken offline through parameter 27-02, the cascade controller will attempt to compensate for the unavailable pump.

- If "Offline-Off" is selected for a pump that is running, a different pump will be staged on to compensate for the loss of output.
- If "Offline-On" is selected for a pump that is currently off, a different pump will be staged off to compensate for the excess output.

6.1.3. Runtime Balancing

The extended cascade controller is designed to balance the running hours between the available pumps. Parameter 27-16 provides a balancing priority for each pump in the system.

Three levels of priority are available:

- Balanced Priority 1
- Balanced Priority 2
- Spare Pump

The cascade controller selects a pump to be staged or de-staged based on the pump's maximum capacity (27-14), the Current Runtime Hours (27-03) and the Runtime Balancing (27-16) parameter.

In selecting the pump to be turned on during staging, the cascade controller will first attempt to evenly balance the current running hours for all of the pumps with a "Balanced Priority 1" in parameter 27-16.

If all of the Priority 1 pumps are running, it will then try to evenly balance the pumps with "Balanced Priority 2" selected.

If all of the Priority 1 and 2 pumps are running, it will then select a pump with "Spare Pump" selected.

During de-staging, this process takes place in reverse. Spare pumps are de-staged first, followed by Priority 2 pumps, followed by Priority 1 pumps. At each priority level, the pump with the greatest number of current runtime hours will be de-staged first.

An exception to this occurs in Mixed Pump configurations with more than one drive. All variable speed pumps are staged on before fixed speed pumps.

Variable speed pumps are also staged off before fixed speed pumps. Parameter 27-19 is used to reset the current runtime hours for all of the pumps and restart the balancing process. This parameter will not affect the Total Lifetime Hours (27-04) for each pump. Total Lifetime Hours is not used for runtime balancing.

6.1.4. Pump Spin for unused pumps

For some installations, not all of the pumps are needed or used on a regular basis. When this occurs, the extended cascade controller will first try to balance the running hours between pumps by alternating when possible. If, however, it is unable to use a pump for 72 hours, it will initiate a pump spin for that pump.

This feature is intended to make sure that no pump is allowed to sit idle for an extended period of time. The Spin Time can be set with parameter 27-18. Spin time should be long enough to ensure that the pump stays in good working condition, but short enough to not create excess pressure within the system. Setting 27-18 to zero disables the function.

The extended cascade controller will not compensate for the extra pressure generated during a pump spin. It is advisable to keep the spin time as short as possible to prevent damage caused by creating excess pressure in the output.

6.1.5. Total lifetime hours

For maintenance purposes, the extended cascade controller is designed to help you keep track of the total lifetime hours for each pump it controls.

The Pump Total Lifetime Hours parameter 27-04 displays a running total of the operating hours for each pump. This parameter is updated whenever a pump is running, and it is saved to non-volatile memory once every hour.

This parameter can also be set to an initial value to reflect the hours of operation for a pump before it was added to the system.

Lifetime hours will only be accumulated by the cascade controller if it is enabled and controlling the pump.

6.1.6. Alternation of the Lead Pump

In a configuration with multiple drives, the lead pump is defined as the last variable speed pump running.

In a configuration with only a single drive, the lead pump is defined as the pump that is connected to the drive. More than one pump can be connected to the drive through contactors that are controlled by the master drive's relays.

Through normal staging and de-staging, the cascade controller will alternate the lead pump to balancing running hours. It will also alternate the lead pump when starting the system or when exiting sleep mode.

However, if the system demand remains below the maximum capacity of the lead pump for a long period of time without entering sleep mode, then it will not alternate the pump. If this scenario is likely to occur, the lead pump can be forced to alternate through a Time Interval parameter 27-52 or through a Time of Day parameter 27-54.

6.1.7. Staging / De-staging in Mixed Pump Configurations

Two methods are used to decide when pumps should be staged or de-staged. The first is the speed of the drives. The second is the feedback pressure going outside of the normal operating range. In a Mixed Pump configuration with more than one drive, both methods are used. In the following example, feedback is referred to as pressure.

Staging:

When the master drive receives a start command, a variable speed pump is selected and started using one of the available drives.

If the system pressure drops, the speed of the drive increases to meet the demand for more flow. While maintaining the pressure, if the drive exceeds the Stage on Speed (27-31), and remains above that speed for the Staging Delay (27-23) time, the next variable speed pump is staged on. This repeats for all of the variable speed pumps.

If the cascade controller is still unable to maintain the system pressure with all of the variable speed pumps on at maximum, it will begin to stage on fixed speed pumps. A fixed speed pump will be staged on when the pressure goes below the setpoint by the Normal Operation Range (27-20) percentage and stays there for the Staging Delay (27-23) time. This repeats for all of the fixed speed pumps.

De-staging:

If the system pressure increases, the speed of all of the drives decrease to match the system's reduced demand for flow. While maintaining pressure, if the drive goes below the Stage off Speed (27-33) and stays there for the De-staging Delay (27-24) time, a variable speed pump will be staged off. This repeats for all of the variable speed pumps except the last one.

If the system pressure is still too high with only one drive running at minimum speed, it will begin to de-stage fixed-speed pumps. A fixed-speed pump will be de-staged when the pressure goes above the setpoint by the Normal Operating Range (27-20) percentage and stays there for the De-staging Delay (27-24) time. This repeats for all of the fixed-speed pumps. This leaves only one variable speed pump running. If the system demand continues to drop, the system will enter sleep mode.

6.1.8. Override Staging / De-staging

Normal staging and de-staging handles most of the situations in typical applications. However, sometimes it is necessary to respond rapidly to changes in system feedback pressure. In these cases, the cascade controller is equipped to immediately stage and de-stage pumps in response to large changes system demand.

Staging:

When the system pressure drops by more than the Override Limit (27-21), the cascade controller will immediately stage on a pump to meet the demand for more flow.

If the system pressure continues to stay below the Override Limit (27-21) for the Override Hold Time (27-25) time, the cascade controller will then stage on the next pump. This repeats until all of the pumps are on or until the system pressure drops below the override limit.

De-staging:

When the system pressure increases rapidly above the Override Limit (27-21), the cascade controller will immediately de-stage a pump to try to reduce the pressure.

If the system pressure continues to stay above the Override Limit (27-21) for the Override Hold Time (27-25) time, the cascade controller will de-stage another pump. This will repeat until only the lead pump is left on or until the pressure stabilizes.

The Override Limit parameter 27-21 is set as a % of the maximum reference. It defines a point above and below the system setpoint where override staging and de-staging will occur.

6.1.9. Minimum Speed De-staging

To reduce emergency usage, the cascade controller will de-stage a pump if the lead pump is running at minimum speed for Min. Speed De-stage Delay (27-27).

6.1.10. Fixed Speed only operation

Fixed Speed only operation is a feature designed to keep critical systems operating in the rare event that all of the variable speed pumps are unavailable to the cascade controller. In this situation, the cascade controller will attempt to maintain system pressure by turning on and off fixed-speed pumps.

Staging:

If all the variable speed pumps are unavailable and the system pressure goes below the Fixed Speed Only Operating Range (27-22) for the Staging Delay (27-23) time, then a fixed-speed pump will be turned on. This repeats until all of the pumps are on.

De-staging:

If all of the variable speed pumps are unavailable and the system pressure goes above the Fixed Speed Only Operating Range (27-22) for the De-stage Delay (27-24) time, a fixed-speed pump will be turned off. This repeats until all of the pumps are off.



7

7. How to Program

7.1. Extended Cascade Controller Parameters

7.1.1. Cascade CTL Option 27-**

Cascade Control Option Parameter group.

7.1.2. Control & Status, 27-0*

Control & Status parameters are for monitoring and manually controlling the pumps.

Use the right [▶] and left [◀] arrow keys to choose a pump. Use the up [▲] and down [▼] arrow keys to change settings.

27-01 Pump Status	
Option:	Function:
	Pump Status is a readout parameter showing the status of each pump in the system. Possibilities are:
Ready	The pump is available for use by the cascade controller.
On Drive	The pump is controlled by the cascade controller, and the pump is connected to a drive, and is running.
On Line Power	The pump is controlled by the cascade controller, and the pump is connected to line power, and is running.
Offline-Off	The pump is not available for use by the cascade controller, and the pump is off.
Offline-On Line Power	The pump is not available for use by the cascade controller, and the pump is connected to line power and is running.
Offline-On Line Power	The pump is not available for use by the cascade controller, and the pump is connected to line power and is running.
Offline-External Inter-lock	The pump has been externally interlocked and is off.
Spinning	The cascade control is executing a spin cycle for the pump.
No Relay Connection	The pump is not directly connected to a drive, and no relay has been assigned to the pump



27-02 Manual Pump Control

Option:
Function:

Manual Pump Control is a command parameter that allows for the manual control of individual pump states. Selecting one of these will execute the command and then return to No Operation. Selections are:

[0] *	No Operation	Does nothing.
[1]	Online	Makes the pump available to the cascade controller.
[2]	Alternate On	Forces the selected pump to become the lead pump.
[3]	Offline-Off	Turns the pump off and makes the pump unavailable for cascading.
[4]	Offline-On	Turns the pump on and makes the pump unavailable for cascading.
[5]	Offline-Spin	Initiates a pump spin.

27-03 Current Runtime Hours

Option:
Function:

Units: hrs

Current Runtime Hours is a readout parameter showing the total number of hours each pump has been running since the last reset. This time is used to balance the running hours between pumps. The times may all be reset to 0 by using parameter 27-91.

27-04 Pump Total Lifetime Hours

Range:
Function:

0* [0 - 2147483647] Pump Total Lifetime Hours is the total operating hours for each connected pump. This parameter may be individually set to any value for maintenance purposes.

7.1.3. Configuration, 27-1*

This parameter group is for configuring the cascade controller option.

27-10 Cascade Controller

Option:
Function:

Cascade Controller Mode sets the operating mode. Selections are:

Disabled	Turns off cascade controller option.
Master/Follower	Operates using only variable speed pumps connected to drives. This selection simplifies the set-up.
Mixed Pumps	Operates using both variable and fixed-speed pumps

Basic Cascade Ctrl Turns off the cascade option and reverts to basic cascade operation (See P25-** in the *VLT AQUA Drive Programming Guide* for further information). The additional relays on the option can be used to extend the basic cascade with 3 relays. Only basic cascade functions are available.

27-11 Number of Drives

Range: 1* [1 - 6] **Function:** Number of Drives specifies the number of drives that are to be controlled by the cascade controller.

27-12 No. of Pumps

Range: Number [No. of Drives - 6] of Drives* **Function:** Number of Pumps sets the number of pumps to be controlled by the cascade controller.

27-14 Pump Capacity

Range: 100%* [0% (Off) - 800%] **Function:** Pump Capacity sets the capacity of each pump in the system, relative to the first pump. This is an indexed parameter with one entry per pump. The capacity of the first pump is always considered to be 100%.

27-16 Runtime Balancing

Option: **Function:** Runtime Balancing sets the priority of each pump for balancing it's running hours. The pumps with the highest priority will be operated before the lower prioritized pumps. If all pumps are set as spare pumps, they will be staged and de-staged as no priorities have been set. It means staged on in the order of 1-2-3 and de-staged 3-2-1. Selections are:

- [0] * Balanced Priority 1 Turned on first, turned off last.
- [1] Balanced Priority 2 Turned on if no priority 1 pumps are available. Turned off before priority 1 pumps are turned off.
- [2] Spare Pump Turned on last, turned off first.

27-17 Motor Starters

Option: **Function:** Motor Starters selects the type of line voltage starters used on the fixed-speed pumps. All of the fixed-speed pumps must be configured the same. Selections are:

None (contactors)

Soft starters

Star-delta starters

27-18 Spin Time for Unused Pumps

Range:

1.0 s* [0.0 s - 99.0 s]

Function:

Spin Time for Unused Pumps sets the length of time to spin unused pumps. If a fixed-speed pump has not been run in the last 72 hours, it will be turned on for this time. This is to prevent damage caused by leaving the pump off too long. The spin feature may be disabled by setting the value of this parameter to 0. Warning - Setting this parameter too high may overpressure some systems.

27-19 Reset Current Runtime Hours

Option:**Function:**

Reset Current Runtime Hours is used to reset all of the Current Runtime Hours to zero. This time is used for runtime balancing. Selections:

[0] * Do not reset

[1] Reset

7

7.1.4. Bandwidth Settings, 27-2*

Parameters for configuring control response.

27-20 Normal Operating Range

Range:

10%* [1% – P27-21]

Function:

Normal Operating Range is the allowed offset from the setpoint before a pump may be added or removed. The system must be outside this limit for the time specified in P27-23 (Staging) or P27-24 (De-staging) before a cascade operation takes place. Normal refers to the system operating with at least one variable speed pump available. This value is entered as a % of Max Reference (See P21-12 in the *VLT AQUA Drive Programming Guide* for further information).

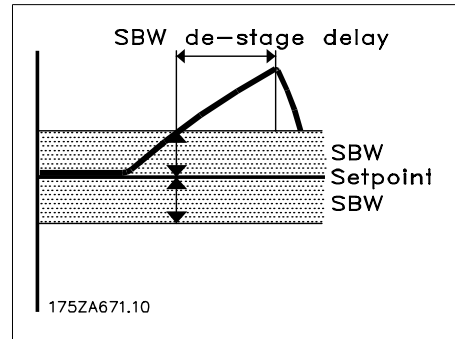
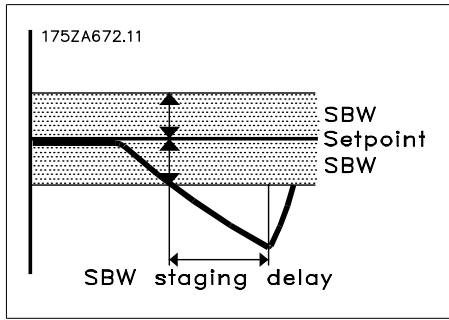

27-21 Override Limit

Range:

100% [P27-20 - 100%]
(Disabled)*

Function:

Override Limit is the allowed offset from the setpoint before a pump will immediately be added or removed (for instance, if a fire tab is switched on). Normal Operating Range includes a delay that limits the system response to transients. This makes the system respond too slowly to large demand changes. The override limit causes the drive to respond immediately. The value is entered as a % of Max Reference (P21-12). Override operation may be disabled by setting this parameter to 100%.

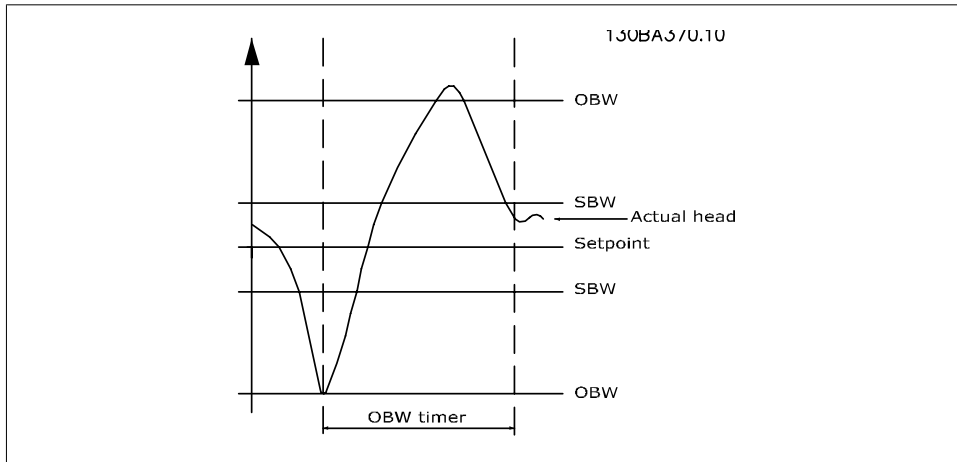

27-22 Fixed Speed Only Operating Range

Range:

P27-20* [P27-20 - P27-21]

Function:

Fixed Speed Only Operating Range is the allowed offset from the setpoint before a pump may be added or removed when there are no operational variable speed pumps. The system must be outside this limit for the time specified in P27-23 (Staging Delay) or P27-24 (De-staging Delay) before a cascade operation may take place. The value is entered as a % of Max Reference. When there are no operational variable speed

pumps, the system will try to maintain control with the remaining fixed-speed pumps.

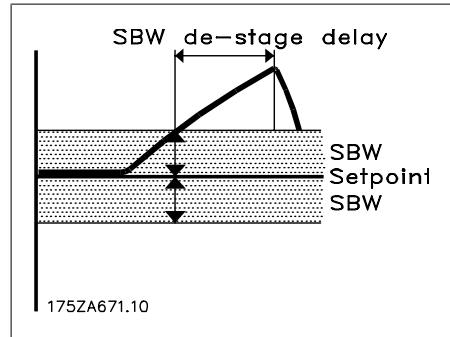
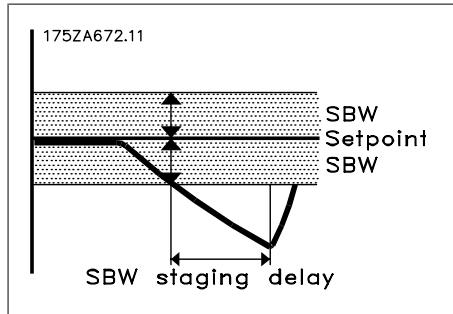

27-23 Staging Delay

Range:

15 s* [0 - 3,000 s]

Function:

Staging Delay is the time that the system feedback must remain below the operating range before a pump may be turned on. If the system is operating with at least one variable speed pump available, the Normal Operating Range (P27-20) is used. If there are no variable speed pumps available, the Fixed Speed Only Operating Range (P27-22) is used.

27-24 De-staging Delay

Range:

15 s* [0 - 3,000 s]

Function:

De-staging Delay is the time that the system feedback must remain above the operating range before a pump may be turned off. If the system is operating with at least one variable speed pump available, the Normal Operating Range (P27-20) is used. If there are no variable speed pumps available, the Fixed Speed Only Operating Range (P27-22) is used.

27-25 Override Hold Time

Range:

10 s* [0 - 300 s]

Function:

Override Hold Time is the minimum time that must elapse following a staging or de-staging, and before a staging or de-staging may take place due to the system exceeding the Override Limit (P27-21). The override hold time is designed to allow the system to stabilize after a pump is turned on or off. If this delay is not long enough, the transients caused by turning a pump on or off may cause the system to add or remove another pump when it should not.

27-27 Min-Speed De-stage Delay

Range:
15 s* [0 - 300 s]

Function:
Min-Speed De-stage Delay is the time that the lead pump must be running at minimum speed with the system feedback still within the normal operating band before a pump will be turned off to save energy. Energy savings may be realized by turning off a pump if the variable speed pumps are operating at minimum speed, with the feedback still in band. Under these conditions, a pump may be turned off and the system will still be able to maintain control. The pumps that remain on will begin operating more efficiently.

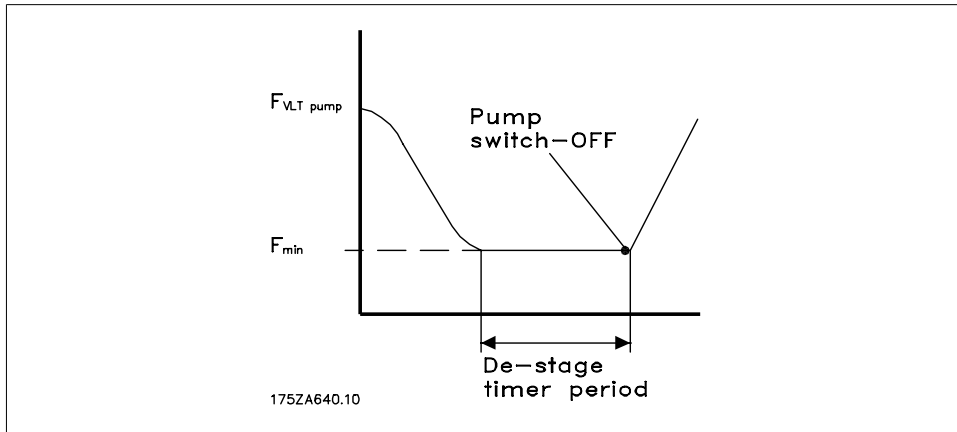

7.1.5. Staging Speed, 27-3*

Parameters for configuring a Master/Follower control response.

27-31 Stage On Speed (RPM)

Range:
P4-13* [P4-11 – P4-13]

Function:
To be used if RPM is chosen. If the lead pump is operating above stage on speed for the time specified in Staging Delay (P27-23), and a variable speed pump is available, it will be turned on.

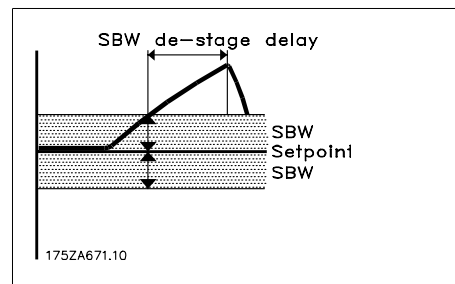
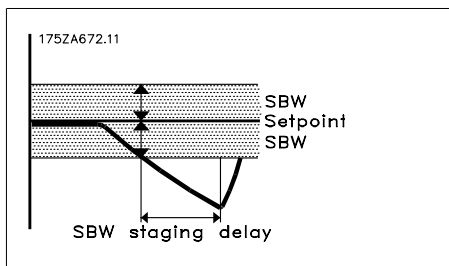

27-32 Stage On Speed (Hz)

Range:

P4-14* [P4-12 – P4-14]

Function:

To be used if Hz is chosen.
If the lead pump is operating above stage on speed for the time specified in Staging Delay (P27-23), and a variable speed pump is available, it will be turned on.

27-33 Stage Off Speed (RPM)

Range:

P4-11* [P4-11 – P4-13]

Function:

If the lead pump is operating below stage off speed for the time specified in De-staging Delay (P27-24), and more than one variable speed pump is on, a variable speed pump will be turned off.

27-34 Stage Off Speed (Hz)

Range:

P4-12* [P4-12 – P4-14]

Function:

If the lead pump is operating below stage off speed for the time specified in De-staging Delay (P27-24), and more than one variable speed pump is on, a variable speed pump will be turned off.

7

7.1.6. Staging Settings, 27-4*

Parameters for configuring staging transitions.

27-41 Ramp-down Delay

Range:

10.0 s* [0.0s – 120.0 s]

Function:

Ramp-down Delay sets the delay between turning on a soft starter controlled pump and ramping down the drive-controlled pump. This is only used for soft starter-controlled pumps.

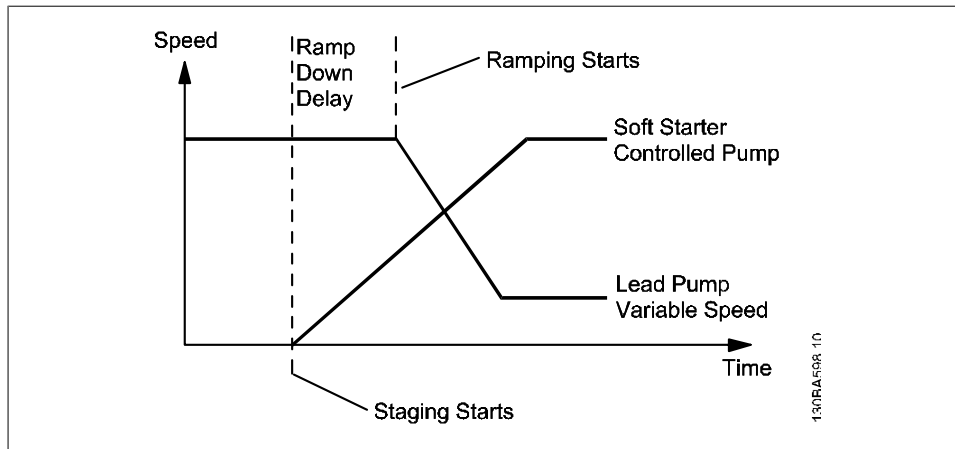

27-42 Ramp-up Delay

Range:
2.0 s* [0.0 s – 12.0 s]

Function:
Ramp-up Delay sets the delay between turning off a soft starter-controlled pump and ramping up the drive-controlled pump. This is only used for soft starter-controlled pumps.

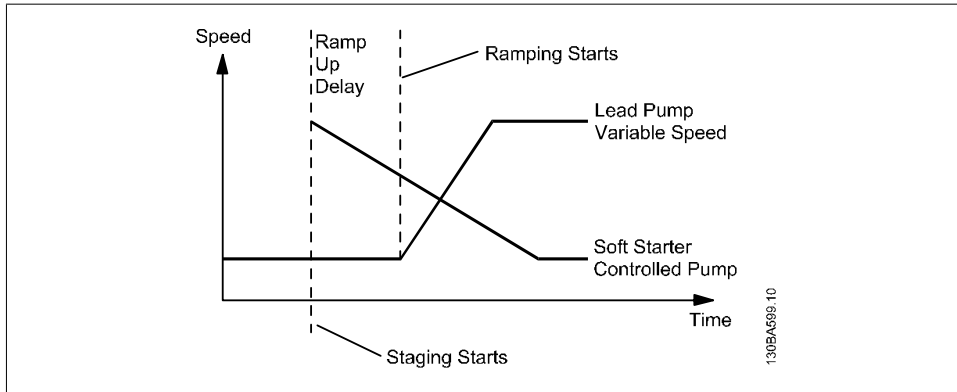

27-43 Staging Threshold

Range:
90%* [1% – 100%]

Function:
Staging Threshold is the speed in the staging ramp at which the fixed speed pump should be turned on. Set as a percentage [%] of maximum pump speed.

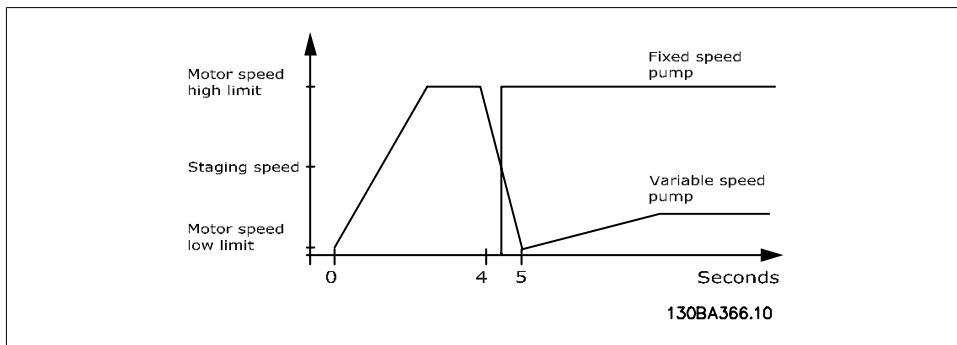

27-44 De-staging Threshold

Range:
50%* [1% – 100%]

Function:
De-staging Threshold is the speed in the staging ramp at which the fixed-speed pump should be turned on. Set as a percentage [%] of maximum pump speed.

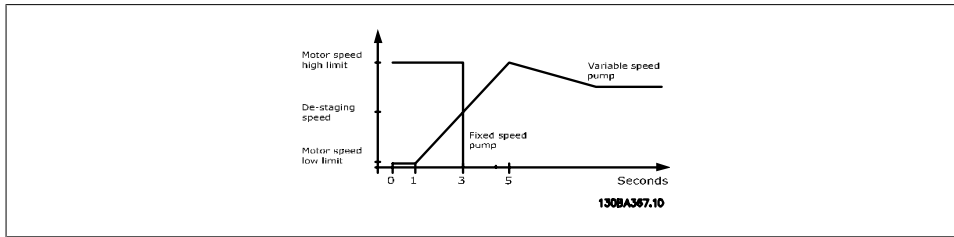

27-45 Staging Speed (rpm)

Option:

Units: RPM

Function:

Staging Speed is a readout parameter that shows the actual staging speed based on the staging threshold.

27-46 Staging Speed (Hz)

Option:

Units: Hz

Function:

Staging Speed is a readout parameter that shows the actual staging speed based on the staging threshold.

27-47 De-staging Speed (rpm)

Option:

Units: rpm

Function:

De-staging Speed is a readout parameter that shows the actual de-staging speed based on the de-staging threshold.

27-48 De-staging Speed (Hz)

Option:

Units: rpm

Function:

De-staging Speed is a readout parameter that shows the actual de-staging speed based on the de-staging threshold.

7.1.7. Alternation Settings, 27-5*

Parameters for configuring alternations.

27-51 Alternation Event

Option:

Function:

Alternation Event allows alternation at destage.

[0] * Off

[1] At De-stage

27-52 Alternation Time Interval

Range:

0 (Disa- [0 (Disabled) – 32808
bled)* ft [10000 m]]

Function:

Alternation Time Interval is the user settable time between alternations. It is disabled by setting it to 0. Parameter 27-53 shows the time remaining until the next alternation occurs.

27-53 Alternation Timer Value

Option:

Units: min

Function:

Alternation Timer Value is a readout parameter that shows the time remaining before an-interval based alternation takes place. Parameter 27-52 sets the time interval

27-54 Alternate at Time of Day

Option:
Function:

Alternate at Time of Day allows the user to select a specific time of day for alternating pumps. The time is set in parameter 27-55. Alternation at Time of Day requires the real time clock to be set.

[0] * Disabled

[1] Time of Day

27-55 Alternation Predefined Time

Range:

1:00* [00:00 – 23:59]

Function:

Alternation Predefined Time is the time of day for pump alternation. This parameter is only available if parameter 27-54 is set to Time of Day.

27-56 Alternate Capacity is <

Range:
0% [0% (Off) – 100%]
(Off)*
Function:

Alternate Capacity is < requires the lead pump to be operating below this capacity before time based alternation will be allowed to take place. This feature ensures that alternation only takes place when the pump is running below a speed where interruption in operation will not affect the process. This minimizes the system disturbance caused by alternations. The value is entered as a % of the capacity of pump 1. Alternate Capacity is < operation may be disabled by setting this parameter to 0%.

27-58 Run Next Pump Delay

Range:

0.1 s* [0.1 s – 5 s]

Function:

Run Next Pump Delay is a delay between stopping the current lead pump and starting the next lead pump when alternating lead pumps. This provides time for the contactors to switch while both pumps are stopped.

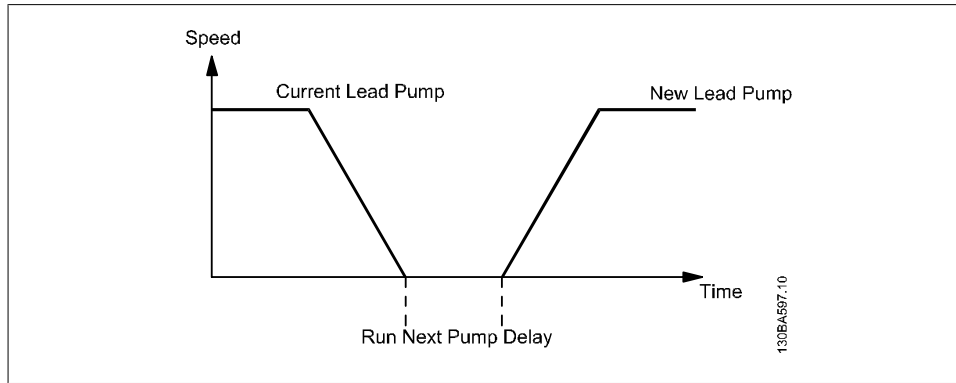

7.1.8. Connections, 27-7*

Parameters for configuring relay connections.

7

27-70 Relay 1

Option:	Function:
Standard Relay	Use as standard relay. Not assigned to cascade controller
[0] Drive X Enable	Enable follower drive X
Pump K to Drive N	Connect pump K to drive N
Pump K to Line Power	Connect pump K to line power

27-71 Relay 2

Option:	Function:
	Relay 2 sets the relay function for Relay 2 in the system. See parameter 27-20 for the available selections.

27-72 Relay 10

Option:	Function:
	Relay 10 sets the relay function for Relay10 in the system. See parameter 27-20 for the available selections.

27-73 Relay 11

Option:	Function:
	Relay 11 sets the relay function for Relay 11 in the system. See parameter 27-20 for the available selections.

27-74 Relay 12

Option:	Function:
	Relay 12 sets the relay function for Relay 12 in the system. See parameter 27-20 for the available selections.

7.1.9. 27-9* Readouts

Cascade Control Option Readout Parameters

27-91 Cascade Reference

Cascade Reference is a readout parameter that shows the reference output for use with follower drives. This reference is available even when the master drive is stopped. This is the speed at which the drive is operating or would be operating if it were on. It is scaled as a percentage of *Motor Speed High Limit* (P4-13[rpm] or P4-14[Hz]).
Units: %

27-92 Current % of Total Capacity

Current % of Total Capacity is a readout parameter that shows the system operating point as a % capacity of total system capacity. 100% means all pumps are on at full speed.
Units: %

27-93 Cascade Option Status

Option:

Function:

Cascade Option Status is a readout parameter to show the status of the cascade system.

[0] *	Disabled	The cascade option is not used.
	Off	The cascade option is turned off.
	Running	The cascade option is running normally.
	Running at FSBW	The cascade option is running in fixed speed mode. No variable speed pumps are available.
	Jogging	The system is running at the jog speed set in P3-11.
	In Open-loop	The system is set to open-loop.
	Frozen	The system is frozen in the current state. No changes will take place.
	Emergency	The system has stopped due to Coast, Safety Interlock, Trip Lock, or Safe Stop.
	Alarm	The system is operating with an alarm condition.
	Staging	A staging operation is in progress.
	De-staging	A de-staging operation is in progress.
	Alternating	An alternation operation is in progress.
	Lead Pump Not Set	A lead pump has not been selected.





New #	Group/Parameter Name	Description	Units	Range	Default	Set-ups	Change During Operation	Conversion	Data Type
Extended/Advanced Cascade Controller Parameters									
Cascade CTL Option 27-**									
27-0*	Control & Status	Current state of each pump in the system	--	Text Readout	Readout	All	Readout	1	
27-01	Pump Status [x6]	Command Parameter	--	[0] - [5]	[0] No Operation	All	TRUE	1	
27-02	Manual Pump Control [x6]	Running hours for this pump since the last reset.	hrs	0 - 2147483647	Readout	All	Readout	1	
27-03	Current Runtime Hours [x6]	Total running hours since this pump was new.	hrs	0 - 2147483647	0	All	TRUE	1	
27-04	Pump Total Lifetime Hours [x6]	Configuration							
27-1*	Cascade Controller	Selects operating mode	--	[0] - [3]	[0] Disabled	All	FALSE	1	
27-10	Number of Drives	Number of drives in this configuration	Drives	1 - 8	1	All	FALSE	1	
27-11	Number of Pumps	Number of pumps in this configuration	Pumps	(27-11) - 8	1	All	FALSE	1	
27-12	Pump Capacity [x6]	Pump Max capacity as a % of 1st pump	% of pump	10% - 800%	100%	All	FALSE	1	
27-14	Runtime Balancing [x6]	Priority for balancing running hrs	--	[0] - [2]	[0] Priority 1	All	TRUE	1	
27-16	Motor Starters	Enables or disables motor starters.	--	[0] - [2]	[0] Direct Online	All	FALSE	1	
27-17	Spin Time for Unused Pumps	On time for pumps after 72 hrs	sec	0.0 (Off) - 99.0 sec	1.0 s	All	TRUE	1	
27-18	Reset Current Runtime Hours	Command Parameter	--	[0] - [1]	[0] Do not reset	All	FALSE	1	
27-19	Bandwidth Settings								
27-2*	Normal Operating Range	Acceptable range around Setpoint (SBW)	% of Max Ref	1% - (27-21)%	10%	All	TRUE	1	
27-20	Override Limit	Too far from setpoint causes staging (OBW)	% of Max Ref	(27-20)% - 100% (Disabled)	100% (Disabled)	All	TRUE	1	
27-21	Fixed Speed Only Operating Range	No Drive range around Setpoint (FSBW)	% of Max Ref	(27-20)% - (27-21)%	10%	All	TRUE	1	
27-22	Staging Delay	Delay time for staging	sec	0 - 3000 sec	15 sec	All	TRUE	1	
27-23	De-staging Delay	Delay time for de-staging	sec	0 - 3000 sec	15 sec	All	TRUE	1	
27-24	Override Hold Time	Min time between staging/de-staging/motor starting	sec	0 - 300 sec	10 sec	All	TRUE	1	
27-25	Min-Speed De-stage Delay	Duration the pump is at min speed before de-staging.	sec	0 - 300 sec (Disabled)	15 sec	All	TRUE	1	
27-27	Staging Speed	Staging Speed for each pump	rpm	(27-33) - Max Ref	(Each Stage Diff)	All	TRUE	1	
27-3*	Stage On Speed [RPM] [x6]	Staging Speed for each pump	Hz	(27-34) - Max Ref	(Each Stage Diff)	All	TRUE	0,1	
27-31	Stage On Speed [Hz] [x6]	De-staging Speed for each pump	rpm	Min Ref - (27-31)	(Each Stage Diff)	All	TRUE	1	
27-32	Stage Off Speed [RPM] [x6]	De-staging Speed for each pump	Hz	Min Ref - (27-32)	(Each Stage Diff)	All	TRUE	0,1	
27-33	Stage Off Speed [Hz] [x6]								





New #	Group/Parameter Name	Description	Extended/Advanced Cascade Controller Parameters				Data Type	
			Units	Range	Default	Set-ups		
27-4*	Staging Settings							
27-41	Ramp-down Delay	Ramp-down Delay for soft starters	sec	0.0 - 120.0 sec	10.0 sec	All	TRUE	0,1
27-42	Ramp-up Delay	Ramp-up Delay for soft starters	sec	0.0 - 12.0 sec	2.0 sec	All	TRUE	0,1
27-43	Staging Threshold	Staging Speed in percent	% Max Ref	1% - 100%	90%	All	TRUE	1
27-44	De-staging Threshold	De-staging Speed in percent	% Max Ref	1% - 100%	50%	All	TRUE	1
27-45	Staging Speed (rpm)	Readout Staging Speed in RPM	rpm	0 - Max Ref	Readout	All	Readout	1
27-46	Staging Speed [Hz]	Readout Staging Speed in Hz	Hz	0 - Max Ref	Readout	All	Readout	1
27-47	De-staging Speed [RPM]	Readout De-staging Speed in RPM	rpm	0 - Max Ref	Readout	All	Readout	1
27-48	De-staging Speed [Hz]	Readout De-staging Speed in Hz	Hz	0 - Max Ref	Readout	All	Readout	1
27-5*	Alternate Settings							
27-51	Alternate Event	Alternate when de-staging a pump.	--	[0] - [1]	[1] At De-stage	All	TRUE	1
27-52	Alternation Time Interval	Time interval between the alternations	min	0 (Disabled) - 10000 min	0 (Disabled)	All	TRUE	1
27-53	Alternation Timer Value	Readout for Alternation timer	min	0 - 10000 min	Readout	All	Readout	1
27-54	Alternate at Time of Day	Alternate on Time of Day	--	[0] - [1]	[0] Disabled	All	TRUE	1
27-55	Alternation Predefined Time	Alternation happens at a particular time of day.	hrs-min	00:00 - 23:59	01:00	All	TRUE	0,001
27-56	Alternate capacity is <	Disable alternation if lead pump is > this speed.	% Max Ref	0% (Off) - 100%	0% (Off)	All	TRUE	1
27-58	Run Next Pump Delay	Lead Pump Alternation to Next Pump Delay	sec	0.1 - 5.0 sec	0.1 sec	All	TRUE	0,1
27-7*	Connections							
27-70	Relay 1	Function for Relay1	--	[0] - [77]	[0] Stand-ard Relay	All	FALSE	1
27-71	Relay 2	Function for Relay 2	--	[0] - [77]	[0] Stand-ard Relay	All	FALSE	1
27-72	Option Relay 10	Function for Option Relay 10	--	[0] - [77]	[0] Stand-ard Relay	All	FALSE	1
27-73	Option Relay 11	Function for Option Relay 11	--	[0] - [77]	[0] Stand-ard Relay	All	FALSE	1
27-74	Option Relay 12	Function for Option Relay 12	--	[0] - [77]	[0] Stand-ard Relay	All	FALSE	1
27-9*	Readouts							
27-91	Cascade Reference	External Reference for follower drives	% Max Ref	0% - 100%	Readout	All	Readout	0,1
27-92	% of Total Capacity	Current operating point	% all pumps	0% - 100%	Readout	All	Readout	1
27-93	Cascade Option Status	Text status for display	--	Text Readout	Readout	All	Readout	1

Index

C

Cascade Controller Features	23
Closed-loop Control	18
Configuring The System	17
Critical Systems	27

D

De-staging	19
Drive Configurations	9

E

Extended Cascade Controller Option	5
------------------------------------	---

F

Feedback Pressure	10, 25
Feedback Sensor	18
Fixed Speed	27
Fixed-speed Pump	6
Fixed-speed Pump Configuration	9
Fixed-speed Pump Configuration	9
Follower Drive	5

G

Ground Leakage Current	3
------------------------	---

L

Lead Pump	25, 27
Lead Pump	25
Lifetime Hours	25

M

Manual Pump Control	23
Master Drive	6, 21
Master/follower Configuration	10
Master-follower Configuration	10
Mixed Pump Configuration	10, 13
Multiple Drives	25
Multiple Unit Staging Efficiency Calculator	19

O

Open-loop Mode	5
Override Limit	26, 33
Override Staging /de-staging	26

P

Pid Controller	18
Pressure Fluctuations	9
Pump Spin	24

R

Runtime Balancing	13, 24
-------------------	--------



S

Safe Stop 21

Single Drive 25

Soft Starters 15

Software Version 3

Spin Time 25, 32

Staging 19

Staging / De-staging 25

Staging And De-staging Decisions 10

Stop Functions 21

Supported Configuration 9

U

Unequal Size Pump Configuration 11

V

Variable Speed Pumps. 6



www.danfoss.com/drives

Danfoss shall not be responsible for any errors in catalogs, brochures or other printed material. Danfoss reserves the right to alter its products at any time without notice, provided that alterations to products already on order shall not require material changes in specifications previously agreed upon by Danfoss and the Purchaser. All trademarks in this material are property of the respective companies. Danfoss and the Danfoss logotype are trademarks of Danfoss A/S. All rights reserved.

For: Industrial Sales, Application Engineering

Danfoss Drives

Division of Danfoss Inc.
4401 N. Bell School Road
Loves Park, IL, 61111
Toll free: 800/432-6367
Telephone: 815/639-8600
Fax: 815/639-8000
www.namc.danfoss.com

For: HVAC Sales, Water Sales, Engineered Panels

Danfoss Graham and Danfoss US Water

Division of Danfoss Inc.
8800 W. Bradley Road
Milwaukee, WI, 53224
Toll free: 800/621-8806
Telephone: 414/355-8800
Fax: 414/355-6117
www.namc.danfoss.com

