



High Power Instruction Manual



VLT® AQUA Drive FC 200



design award
winner
2004

Contents

1. How to Read the Instruction Manual	5
Copyright, Limitation of Liability and Revision Rights	5
Approvals	6
Symbols	6
2. Safety	7
General Warning	8
Before Commencing Repair Work	8
Special conditions	8
Avoid unintended Start.	9
Safe Stop Installation	10
Safe Stop of the Adjustable Frequency Drive	11
IT Line	13
3. How to Install	15
How to Get Started	15
Pre-installation	16
Planning the Installation Site	16
Receiving the Adjustable Frequency Drive	16
Transportation and Unpacking	16
Lifting	17
Rated Power	18
Mechanical Dimensions	19
Mechanical Installation	20
Tools Needed	20
General Considerations	20
Installation in Enclosures - IP 00 / Chassis units	29
Installation on the Wall - IP 21 (NEMA 1) and IP 54 (NEMA 12) Units	29
Floor Mounting - Pedestal Installation IP 21 (NEMA1) and IP 54 (NEMA12)	30
Gland/Conduit Entry - IP 21 (NEMA 1) and IP 54 (NEMA12)	32
IP 21 Drip shield installation (D1 and D2 enclosure)	33
Field Installation of Options	33
Installation on pedestal	43
Electrical Installation	46
Control Wires	46
Power Connections	47

Line connection	56
Fuses	57
Electrical Installation, Control Terminals	60
Connection Examples	62
Start/Stop	62
Pulse Start/Stop	62
Speed Up/Slow	63
Potentiometer Reference	63
Electrical Installation - continued	64
Electrical Installation, Control Cables	64
Switches S201, S202, and S801	66
Final Set-up and Test	67
Additional Connections	69
Motor Thermal Protection	69
4. How to program the adjustable frequency drive	71
How to program	71
Initialization to Default Settings	99
Parameter Options	100
Default settings	100
0-** Operation/Display	101
1-** Load/Motor	103
2-** Brakes	104
3-** Reference / Ramps	105
4-** Limits / Warnings	106
5-** Digital In/Out	107
6-** Analog In/Out	109
8-** Comm. and Options	111
9-** Profibus	112
10-** CAN Ser. Com. Bus	113
13-** Smart Logic	114
14-** Special Functions	115
15-** FC Information	116
16-** Data Readouts	118
18-** Data Readouts 2	120
20-** FC Closed-loop	121
21-** Ext. Closed-loop	122

22-** Application Functions	124
23-** Timed Actions	126
25-** Cascade Controller	127
26-** Analog I/O Option MCB 109	129
29-** Water Application Functions	130
31-** Bypass Option	131
5. General Specifications	133
6. Troubleshooting	141
Warning/Alarm list	143
7. Annexes	147
Index	153



1

1. How to Read the Instruction Manual

1

1.1.1. Copyright, Limitation of Liability and Revision Rights

This publication contains information proprietary to Danfoss A/S. By accepting and using this manual, the user agrees that the information contained herein will be used solely for operating equipment from Danfoss A/S or equipment from other vendors, provided that such equipment is intended for communication with Danfoss equipment over a serial communication link. This publication is protected under the copyright laws of Denmark and most other countries.

Danfoss A/S does not guarantee that a software program produced according to the guidelines provided in this manual will function properly in every physical, hardware or software environment.

Although Danfoss A/S has tested and reviewed the documentation within this manual, Danfoss A/S makes no warranty or representation, neither expressed nor implied, with respect to this documentation, including its quality, performance or fitness for a particular purpose.

In no event shall Danfoss A/S be liable for direct, indirect, special, incidental or consequential damages arising from the use or the inability to use information contained in this manual, even if advised of the possibility of such damages. In particular, Danfoss A/S is not responsible for any costs, including, but not limited to, those incurred as a result of lost profits or revenue, loss of or damages to equipment, loss of computer programs, loss of data, the costs to substitute these, or any claims by third parties.

Danfoss A/S reserves the right to revise this publication at any time and to make changes to its contents without prior notice or any obligation to notify former or present users of such revisions or changes.

This Instruction Manual will introduce all aspects of your VLT AQUA Drive.

Available literature for VLT AQUA Drive:

- The Instruction Manual MG.20.MX.YY provides the necessary information for getting the drive up and running.
- The Design Guide MG.20.NX.YY contains technical information about the drive design and customer applications.
- The Programming Guide MG.20.OX.YY provides information on how to program and includes complete parameter descriptions.

X = Revision number

YY = Language code

Danfoss Drives technical literature is also available online at www.danfoss.com/BusinessAreas/DrivesSolutions/Documentations/Technical+Documentation.

1

1.1.2. Approvals

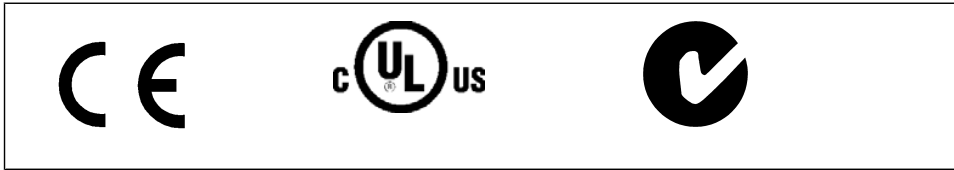

1.1.3. Symbols

Symbols used in this Instruction Manual.

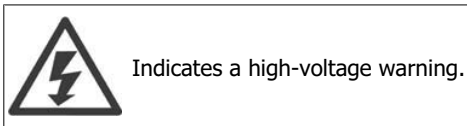
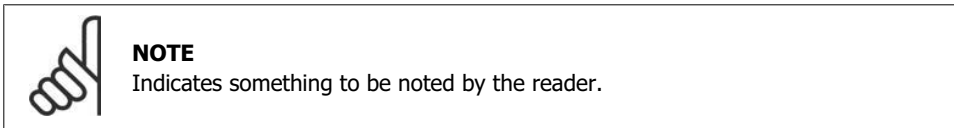

2. Safety

2

2.1.1. Safety note



The voltage of the adjustable frequency drive is dangerous whenever connected to line power. Incorrect installation of the motor, adjustable frequency drive or serial communication bus may cause damage to the equipment, serious personal injury or death. Consequently, the instructions in this manual, as well as national and local rules and safety regulations, must be followed.

Safety Regulations

1. The adjustable frequency drive must be disconnected from line power if repair work is to be carried out. Make sure that the line supply has been disconnected and that the necessary time has passed before removing motor and line plugs.
2. The [STOP/RESET] key on the control panel of the adjustable frequency drive does not disconnect the equipment from line power and is thus not to be used as a safety switch.
3. Correct protective grounding of the equipment must be established, the user must be protected against supply voltage, and the motor must be protected against overload in accordance with applicable national and local regulations.
4. The ground leakage currents are higher than 3.5 mA.
5. Protection against motor overload is set by par. 1-90 *Motor Thermal Protection*. If this function is desired, set par. 1-90 to data value [ETR trip] (default value) or data value [ETR warning]. Note: The function is initialized at 1.16 x rated motor current and rated motor frequency. For the North American market: The ETR functions provide class 20 motor overload protection in accordance with NEC.
6. Do not remove the plugs for the motor and line supply while the adjustable frequency drive is connected to line power. Make sure that the line supply has been disconnected and that the necessary time has passed before removing motor and line plugs.
7. Please note that the adjustable frequency drive has more voltage inputs than L1, L2 and L3 when load sharing (linking of the DC intermediate circuit) and external 24 V DC have been installed. Make sure that all voltage inputs have been disconnected and that the necessary time has passed before commencing repair work.

Installation at High Altitudes



At altitudes higher than 6,600 feet [2 km], please contact Danfoss Drives regarding PELV.

Warning against Unintended Start

1. The motor can be brought to a stop by means of digital commands, bus commands, references or a local stop while the adjustable frequency drive is connected to line power. If personal safety considerations make it necessary to ensure that no unintended start occurs, these stop functions are not sufficient. 2. While parameters are being changed, the motor may start. Consequently, the stop key [STOP/RESET] must always be activated, following which data can be modified. 3. A motor that has been stopped may start if faults occur in the electronics of the adjustable frequency drive, or if a temporary overload or a fault in the supply line or the motor connection ceases.

**Warning:**

Touching the electrical parts may be fatal - even after the equipment has been disconnected from line power.

Also, make sure that other voltage inputs have been disconnected, such as external 24 V DC, load sharing (linkage of DC intermediate circuit), as well as the motor connection for kinetic backup.

2.1.2. General Warning

**Warning:**

Touching the electrical parts may be fatal - even after the equipment has been disconnected from line power.

Also make sure that other voltage inputs have been disconnected, (linkage of DC intermediate circuit), as well as the motor connection for kinetic backup.

Before touching any potentially live parts of the VLT AQUA Drive FC 200, wait at least the minimum time as follows:

380-480 V, 150-600 hp [110-450 kW], wait at least 15 minutes.

525-690 V, 175-850 hp [132-630 kW], wait at least 20 minutes.

A shorter time is allowed only if indicated on the nameplate for the specific unit.

**Leakage Current**

The ground leakage current from the VLT AQUA Drive FC 200 exceeds 3.5 mA. According to IEC 61800-5-1, a reinforced protective ground connection must be ensured by means of: a min. 0.015 in² [10 mm²] Cu or 0.025 in² [16 mm²] Al PE wire or an additional PE wire, with the same cable cross-section as the line power wiring, must be terminated separately.

Residual Current Device

This product can cause DC current in the protective conductor. If a residual current device (RCD) is used for extra protection, only an RCD of Type B (time delayed) may be used on the supply side of this product. See also RCD Application Note MN.90.GX.02.

Protective grounding of the VLT AQUA Drive FC 200 and the use of RCDs must always follow national and local regulations.

2.1.3. Before Commencing Repair Work

1. Disconnect the adjustable frequency drive from the line power.
2. Disconnect DC bus terminals 88 and 89.
3. Wait at least as long as the time mentioned in section 2.1.2.
4. Remove motor cable.

2.1.4. Special conditions

Electrical ratings:

The rating indicated on the nameplate of the adjustable frequency drive is based on a typical 3-phase line power supply within the specified voltage, current and temperature ranges, which are expected to be used in most applications.

The adjustable frequency drives also support other special applications, which affect the electrical ratings of the adjustable frequency drive. Special conditions that affect the electrical ratings might be:

- Single phase applications.
- High temperature applications which require derating of the electrical ratings
- Marine applications with more severe environmental conditions.

Consult the relevant clauses in these instructions and in the **VLT® AQUA Drive Design Guide** for information about the electrical ratings.

Installation requirements:

The overall electrical safety of the adjustable frequency drive requires special installation considerations regarding:

- Fuses and circuit breakers for overcurrent and short-circuit protection
- Selection of power cables (line power, motor, brake, load sharing and relay)
- Grid configuration (IT,TN, grounded leg, etc.)
- Safety of low-voltage ports (PELV conditions).

Consult the relevant clauses in these instructions and in the **VLT® AQUA Drive Design Guide** for information about the installation requirements.

2.1.5. Caution

The adjustable frequency drive DC link capacitors remain charged after power has been disconnected. To avoid the risk of electrical shock, disconnect the adjustable frequency drive from the line power before performing maintenance procedures. Wait at least as long as follows before servicing the adjustable frequency drive:

Voltage	Min. Waiting Time	
	15 min.	20 min.
380-480 V	150-600 hp [110-450 kW]	
525-690 V	175-850 hp [132-630 kW]	
Be aware that there may be high voltage on the DC link even when the LEDs are turned off.		

2.1.6. Avoid unintended Start.

While the adjustable frequency drive is connected to line power, the motor can be started/stopped using digital commands, bus commands, references or via the Local Control Panel.

- Disconnect the adjustable frequency drive from line power whenever personal safety considerations make it necessary to avoid an unintended start.
- To avoid an unintended start, always activate the [OFF] key before changing parameters.
- Unless terminal 37 is turned off, an electronic fault, temporary overload, a fault in the line supply or lost motor connection may cause a stopped motor to start.

2.1.7. Safe Stop Installation

To carry out an installation of a Category 0 Stop (EN60204) in conformity with Safety Category 3 (EN954-1), follow these instructions:

1. The bridge (jumper) between Terminal 37 and 24 V DC must be removed. Cutting or breaking the jumper is not sufficient. Remove it entirely to avoid short-circuiting. See jumper on illustration.
2. Connect terminal 37 to 24 V DC by a short circuit-protected cable. The 24 V DC voltage supply must be interruptible by an EN954-1 category 3 circuit interrupt device. If the interrupt device and the adjustable frequency drive are placed in the same installation panel, you can use an unshielded cable instead of a shielded one.

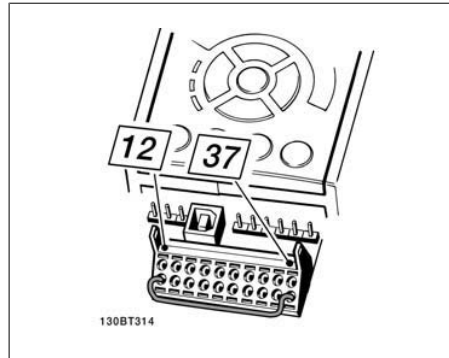

2.1: Bridge jumper between terminal 37 and 24 VDC

The illustration below shows a Stopping Category 0 (EN 60204-1) with safety Category 3 (EN 954-1). The circuit interruption is caused by an opening door contact. The illustration also shows how to connect a non-safety-related hardware coast.

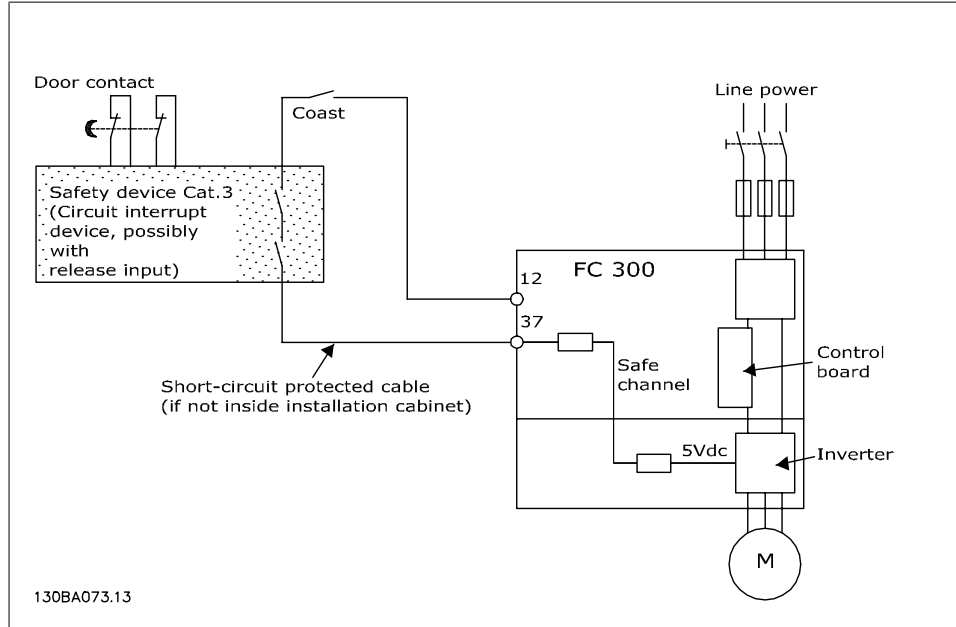

2.2: Illustration of the essential aspects of an installation to achieve a Stopping Category 0 (EN 60204-1) with safety Category 3 (EN 954-1).

2.1.8. Safe Stop of the Adjustable Frequency Drive

For versions fitted with a safe stop terminal 37 input, the adjustable frequency drive can perform the safety function *Safe Torque Off* (As defined by draft CD IEC 61800-5-2) or *Stop Category 0* (as defined in EN 60204-1).

It is designed and deemed suitable for the requirements of Safety Category 3 in EN 954-1. This function is called safe stop. Prior to integrating and using safe stop in an installation, a thorough risk analysis must be carried out on the installation in order to determine whether the safe stop functionality and safety category are appropriate and sufficient. In order to install and use the Safe Stop function in accordance with the requirements of Safety Category 3 in EN 954-1, the related information and instructions of the VLT AQUA Drive Design Guide MG.20.NX.YY must be followed! The information and instructions contained in the Instruction Manual are not sufficient for a correct and safe use of the safe stop functionality!



Prüf- und Zertifizierungsstelle im BG-PRÜFZERT		BGIA Berufsgenossenschaftliches Institut für Arbeitsschutz <small>Hauptverband der gewerblichen Berufsgenossenschaften</small>		130BA373.10
Type Test Certificate		05 06004 <small>No. of certificate</small>		
<small>Translation In any case, the German original shall prevail.</small>				
Name and address of the holder of the certificate (customer)		Danfoss Drives A/S, Ulnoes 1 DK-6300 Graasten, Dänemark		
Name and address of the manufacturer:		Danfoss Drives A/S, Ulnoes 1 DK-6300 Graasten, Dänemark		
Ref. of customer:	Ref. of Test and Certification Body: <small>Apf/KAb-VI-Nr. 2003 23220</small>	Date of Issue: 13.04.2005		
Product designation:	Frequency converter with integrated safety functions			
Type:	VLT® Automation Drive FC 302			
Intended purpose:	Implementation of safety function „Safe Stop“			
Testing based on:	EN 954-1, 1997-03, DIN AK 226.03, 1998-06, EN ISO 13849-2: 2003-12, EN 61800-3, 2001-02, EN 61800-5-1, 2003-09.			
Test certificate:	No.: 2003 23220 from 13.04.2005			
Remarks:	The presented types of the frequency converter FC 302 meet the requirements laid down in the test bases. With correct wiring a category 3 according to DIN EN 954-1 is reached for the safety function.			
The type tested complies with the provisions laid down in the directive 98/37/EC (Machinery).				
Further conditions are laid down in the Rules of Procedure for Testing and Certification of April 2004.				
Head of certification body <small>(Prof. Dr. rer. nat. Diemar Rainert)</small>		Certification officer <small>(Dipl.-Ing. R. Apfeld)</small>		
PZ3108 01.03	Postal address: 53754 Seckel-Angeln	Office: Althausstraße 111 53757 Seckel-Angeln	Phone: 0 22 41/2 31-02 Fax: 0 22 41/2 31-22 34	

2

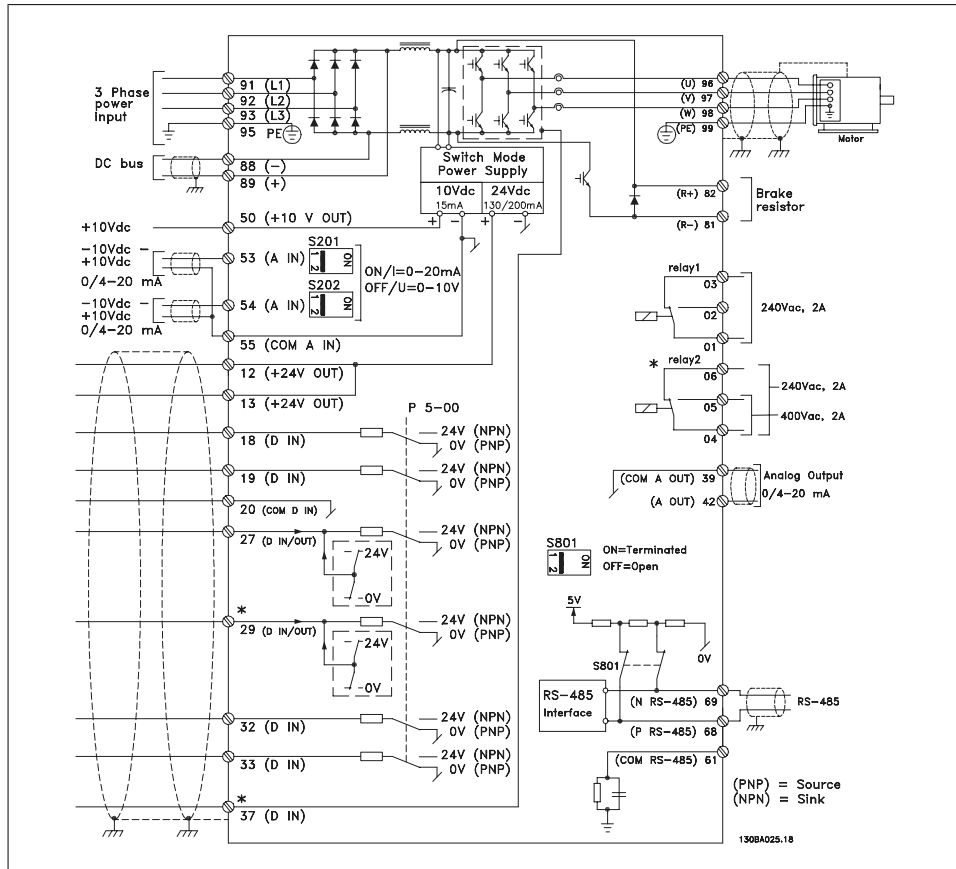

2.1.9. IT Line



IT Line

Do not connect 400 V adjustable frequency drives with RFI filters to line supplies with a voltage between phase and ground of more than 440 V.
For IT lines and delta ground (grounded leg), line voltage may exceed 440 V between phase and ground.

2

Par. 14-50 *RFI 1* can be used to disconnect the internal RFI capacitors from the RFI filter to ground. If this is done, it will reduce the RFI performance to A2 level.

2.1.10. Software Version and Approvals: VLT AQUA Drive

VLT AQUA Drive
Instruction Manual
Software version: 1.00



This instruction manual can be used for all VLT AQUA Drive adjustable frequency drives with software version 1.00.
The software version number can be seen in parameter 15-43.

2.1.11. Disposal Instructions



Equipment containing electrical components may not be disposed of together with domestic waste.
It must be separately collected with electrical and electronic waste according to local and currently valid legislation.



3

3. How to Install

3.1. How to Get Started

3.1.1. About How to Install

This chapter covers mechanical and electrical installations to and from power terminals and control card terminals.

Electrical installation of *options* is described in the relevant Instruction Manual and Design Guide.

3.1.2. How to Get Started

The adjustable frequency drive is designed for quick installation and is EMC-compliant. Just follow the steps described below.



Read the safety instructions before installing the unit.

Mechanical Installation

- Mechanical mounting

Electrical Installation

- Connection to Line and Protecting Ground
- Motor connection and cables
- Fuses and circuit breakers
- Control terminals - cables

Quick set-up

- Local Control Panel, LCP
- Automatic Motor Adaptation, AMA
- Programming

Frame size is dependent on enclosure type, power range and line voltage.

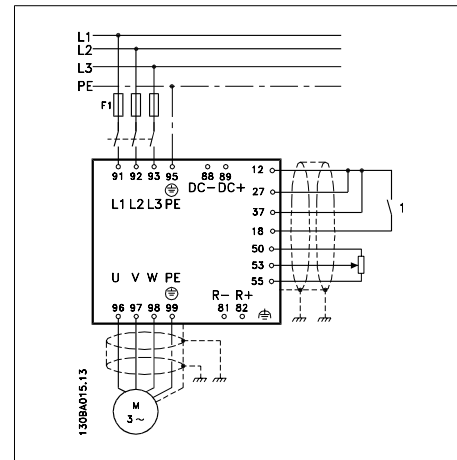

3.1: Diagram showing basic installation including line power, motor, start/stop key, and potentiometer for speed adjustment.

3.2. Pre-installation

3.2.1. Planning the Installation Site

**NOTE**

Before performing the installation, it is important to plan the installation of the adjustable frequency drive. Neglecting this may result in extra work during and after installation.

Select the best possible operation site by considering the following (see details on the following pages and in the respective Design Guides):

- Ambient operating temperature
- Installation method
- How to cool the unit
- Position of the adjustable frequency drive.
- Cable routing
- Ensure the power source supplies the correct voltage and necessary current.
- Ensure that the motor current rating is within the maximum current from the adjustable frequency drive.
- If the adjustable frequency drive is without built-in fuses, ensure that the external fuses are rated correctly.

3.2.2. Receiving the Adjustable Frequency Drive

When receiving the adjustable frequency drive, make sure that the packaging is intact, and look for any damage that might have occurred to the unit during transport. If damage has occurred, immediately contact the shipping company to make a damage claim.

3.2.3. Transportation and Unpacking

Before unpacking the adjustable frequency drive, it is recommended to unload it as close as possible to the final installation site.

Remove the cardboard box and keep the adjustable frequency drive on the pallet as long as possible. Remark: The cardboard box cover contains a drilling master for the mounting holes.

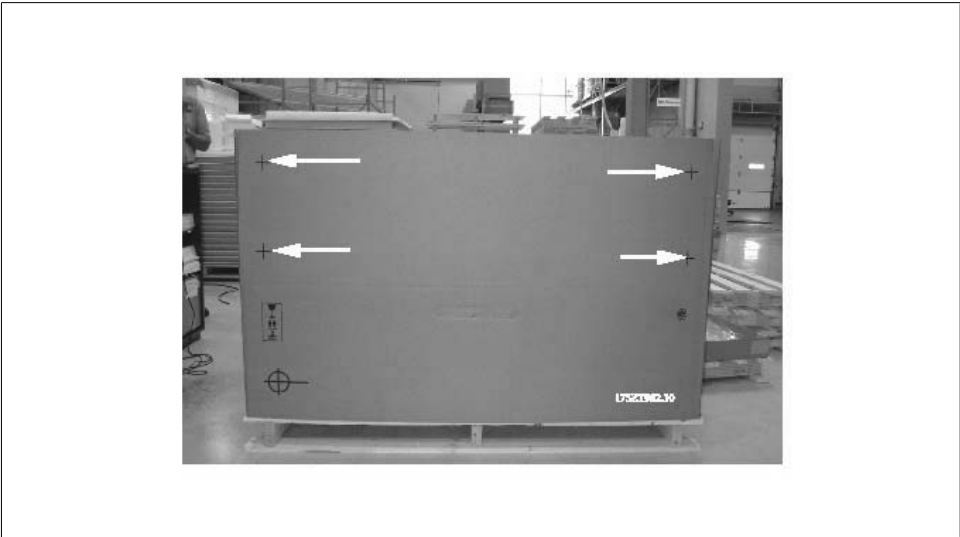

3.2: Mounting Template

3.2.4. Lifting

Always lift the adjustable frequency drive using the dedicated lifting holes. Use a bar to avoid bending the lifting holes of the adjustable frequency drive.

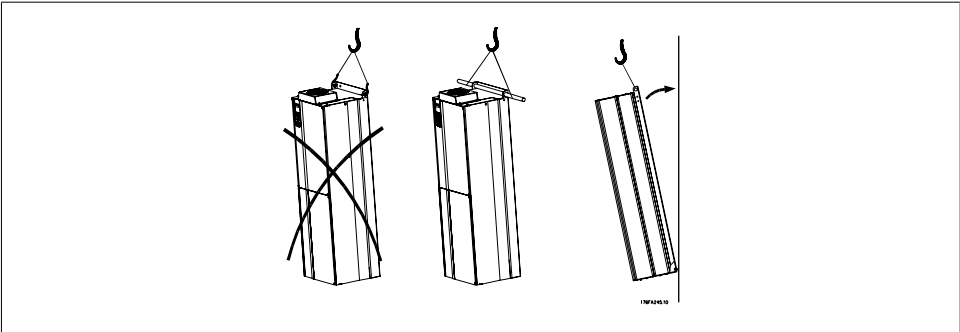

3.3: Recommended lifting method

3.3.1. Rated Power

Enclosure type	D1		D2		D3		D4		E1		E2	
	Type 1/	Type 12	Type 1/	Type 12	Chassis	Chassis	Type 1/	Type 12	Type 1/	Type 12	Chassis	Chassis
Enclosure protection	IP 21/54		IP 21/54		IP 00		IP 00		IP 21/54		IP 00	
Rated power	150-175 hp [110-132 kW] at 400 V (380-480 V)	125-250 hp [110-160 kW] at 600 V (525-690 V)	200-350 hp [150-250 kW] at 400 V (380-480 V)	300-550 hp [200-400 kW] at 600 V (525-690 V)	150-175 hp [110-132 kW] at 400 V (380-480 V)	275-250 hp [132-160 kW] at 600 V (525-690 V)	200-350 hp [150-250 kW] at 400 V (380-480 V)	300-550 hp [200-400 kW] at 600 V (525-690 V)	450-600 hp [315-450 kW] at 400 V (380-480 V)	600-850 hp [450-630 kW] at 600 V (525-690 V)	450-600 hp [315-450 kW] at 400 V (380-480 V)	600-850 hp [450-630 kW] at 600 V (525-690 V)

3.3.2. Mechanical Dimensions

Mechanical dimensions, D Enclosures						
Frame size	D1		D2		D3	D4
	150-175 hp [110-132 kW] (380-480 V)		200-350 hp [150-250 kW] (380-480 V)		150-175 hp [110-132 kW] (380-480 V)	200-350 hp [150-250 kW] (380-480 V)
	175-250 hp [132-160 kW] (525-690 V)		300-550 hp [200-400 kW] (525-690 V)		175-250 hp [132-160 kW] (525-690 V)	300-550 hp [200-400 kW] (525-690 V)
IP NEMA	21 Type 1	54 Type 12	21 Type 1	54 Type 12	00 Chassis	00 Chassis
Cardboard box size Shipping dimensions	Height	25.6 in [650 mm]	25.6 in [650 mm]	25.6 in [650 mm]	25.6 in [650 mm]	25.6 in [650 mm]
	Width	68.1 in [1730 mm]	68.1 in [1730 mm]	68.1 in [1730 mm]	68.1 in [1730 mm]	58.7 in [1490 mm]
	Depth	22.4 in [570 mm]	22.4 in [570 mm]	22.4 in [570 mm]	22.4 in [570 mm]	22.4 in [570 mm]
Drive dimensions	Height	45.6 in [1159 mm]	45.6 in [1159 mm]	60.6 in [1540 mm]	60.6 in [1540 mm]	50.3 in [1277 mm]
	Width	16.5 in [420 mm]	16.5 in [420 mm]	16.5 in [420 mm]	16.5 in [420 mm]	16.1 in [408 mm]
	Depth	14.7 in [373 mm]	14.7 in [373 mm]	14.7 in [373 mm]	14.7 in [373 mm]	14.7 in [373 mm]
Max weight	229.3 lbs [104 kg]	229.3 lbs [104 kg]	332.9 lbs [151 kg]	332.9 lbs [151 kg]	200.6 lbs [91 kg]	304.2 lbs [138 kg]

Mechanical dimensions, E Enclosures			
Frame size	E1		E2
	450-600 hp [315-450 kW] (380-480 V)		450-600 hp [315-450 kW] (380-480 V)
	600-850 hp [450-630 kW] (525-690 V)		600-850 hp [450-630 kW] (525-690 V)
IP NEMA	21 Type 12	54 Type 12	00 Chassis
Cardboard box size Shipping dimensions	Height	33.1 in [840 mm]	32.7 in [831 mm]
	Width	86.5 in [2197 mm]	67.1 in [1705 mm]
	Depth	29 in [736 mm]	29 in [736 mm]
Drive dimensions	Height	78.7 in [2000 mm]	59 in [1499 mm]
	Width	23.6 in [600 mm]	23 in [585 mm]
	Depth	19.5 in [494 mm]	19.5 in [494 mm]
Max weight	690 lbs [313 kg]	690 lbs [313 kg]	611 lbs [277 kg]

3.4. Mechanical Installation

Preparation of the mechanical installation of the adjustable frequency drive must be done carefully to ensure proper results and to avoid additional work during installation. Start by taking a close look at the mechanical drawings at the end of this instruction manual to become familiar with the space demands.

3.4.1. Tools Needed

To perform the mechanical installation, the following tools are needed:

- Drill with 0.39 or 0.47 in [10 or 12 mm] drill.
- Tape measure
- Wrench with relevant metric sockets (7-17 mm)
- Extensions to wrench
- Sheet metal punch for conduits or cable glands in IP 21 and IP 54 units
- Lifting bar to lift the unit (rod or tube \varnothing 0.75 in [20 mm]) able to lift minimum 880 lbs [400 kg].
- Crane or other lifting aid to place the adjustable frequency drive in position
- A Torx T50 tool is needed to install the E1 enclosure in IP 21 and IP 54 enclosure types.

3.4.2. General Considerations

Space

Ensure proper clearance space above and below the adjustable frequency drive to allow airflow and cable access. In addition, space in front of the unit must be considered to enable opening the door of the panel.

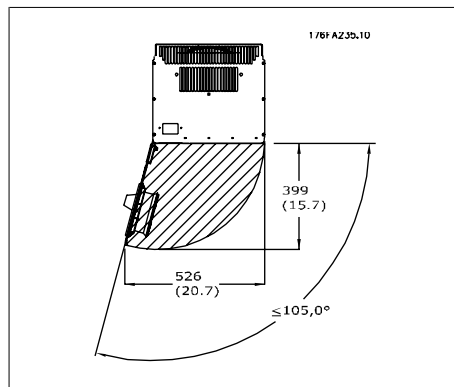

3.4: Space in front of IP 21/IP 54 enclosure type D1 and D2.

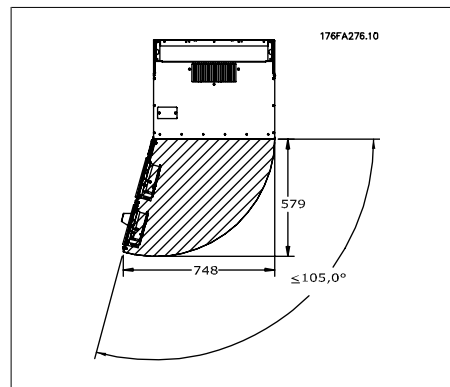

3.5: Space in front of IP 21/IP 54 enclosure type E1.

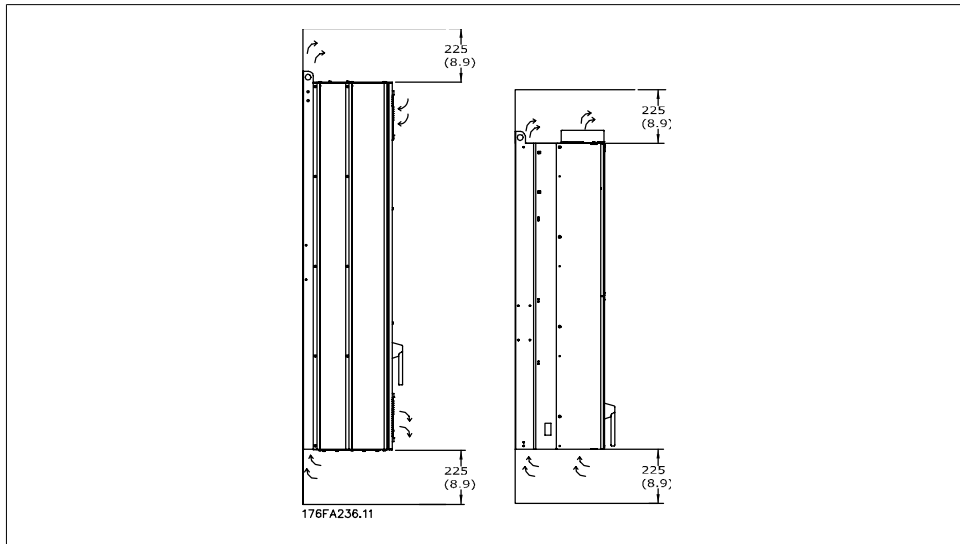

3.6: Airflow direction and necessary space for cooling

Left: Enclosure IP 21/IP 54, D1 and D2.

Right: Enclosure IP 00, D3, D4 and E2.

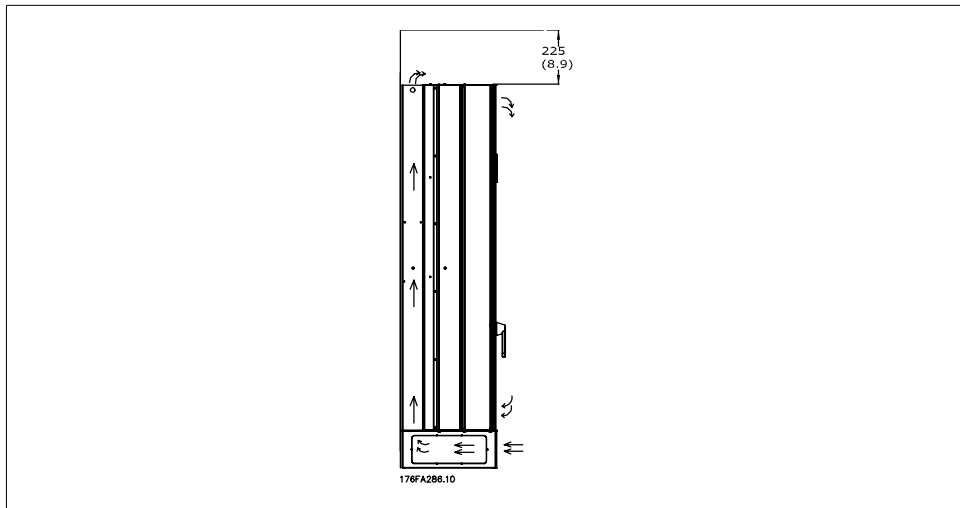

3.7: Airflow direction and necessary space for cooling - Enclosure IP 21/IP 54, E1

Wire access

Ensure that proper cable access is present including the necessary bending allowance. Since the IP 00 enclosure is open, the bottom cables must be attached to the back panel of the enclosure where the adjustable frequency drive is mounted, i.e., by using cable clamps.

Terminal locations**(D1 and D2 enclosures)**

Take the following terminal positions into consideration when you design for cable access.

3

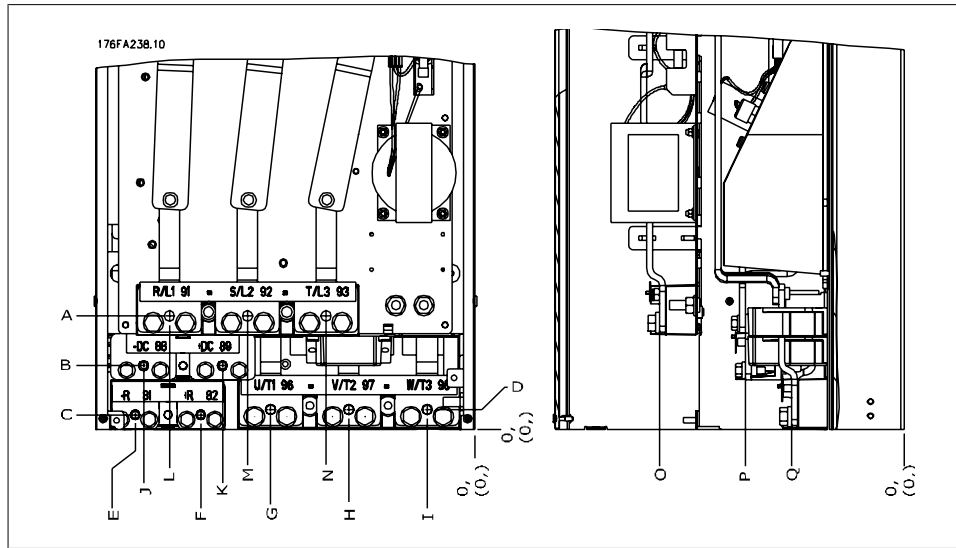

3.8: Position of power connections

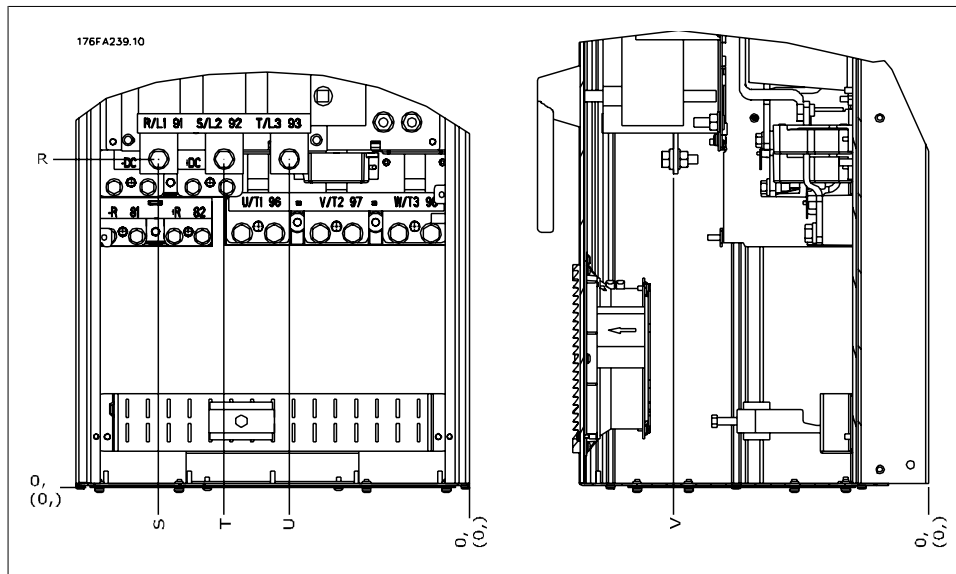

3.9: Position of power connections - Disconnect

Be aware that the power cables are heavy and hard to bend. Give thought to the optimum position of the adjustable frequency drive for ensuring easy installation of the cables.

	IP 21 (NEMA 1) / IP 54 (NEMA 12)		IP 00 / Chassis	
	Enclosure D1	Enclosure D2	Enclosure D3	Enclosure D4
A	277 (10.9)	379 (14.9)	119 (4.7)	122 (4.8)
B	227 (8.9)	326 (12.8)	68 (2.7)	68 (2.7)
C	173 (6.8)	273 (10.8)	15 (0.6)	16 (0.6)
D	179 (7.0)	279 (11.0)	20.7 (0.8)	22 (0.8)
E	370 (14.6)	370 (14.6)	363 (14.3)	363 (14.3)
F	300 (11.8)	300 (11.8)	293 (11.5)	293 (11.5)
G	222 (8.7)	226 (8.9)	215 (8.4)	218 (8.6)
H	139 (5.4)	142 (5.6)	131 (5.2)	135 (5.3)
I	55 (2.2)	59 (2.3)	48 (1.9)	51 (2.0)
J	354 (13.9)	361 (14.2)	347 (13.6)	354 (13.9)
K	284 (11.2)	277 (10.9)	277 (10.9)	270 (10.6)
L	334 (13.1)	334 (13.1)	326 (12.8)	326 (12.8)
M	250 (9.8)	250 (9.8)	243 (9.6)	243 (9.6)
N	167 (6.6)	167 (6.6)	159 (6.3)	159 (6.3)
O	261 (10.3)	260 (10.3)	261 (10.3)	261 (10.3)
P	170 (6.7)	169 (6.7)	170 (6.7)	170 (6.7)
Q	120 (4.7)	120 (4.7)	120 (4.7)	120 (4.7)
R	256 (10.1)	350 (13.8)	98 (3.8)	93 (3.7)
S	308 (12.1)	332 (13.0)	301 (11.8)	324 (12.8)
T	252 (9.9)	262 (10.3)	245 (9.6)	255 (10.0)
U	196 (7.7)	192 (7.6)	189 (7.4)	185 (7.3)
V	260 (10.2)	273 (10.7)	260 (10.2)	273 (10.7)

3.1: Cable positions as shown in the drawings above. Dimensions in inches [mm].

Terminal locations - E1 enclosures

Give thought to the following terminal positions when designing the cable access.

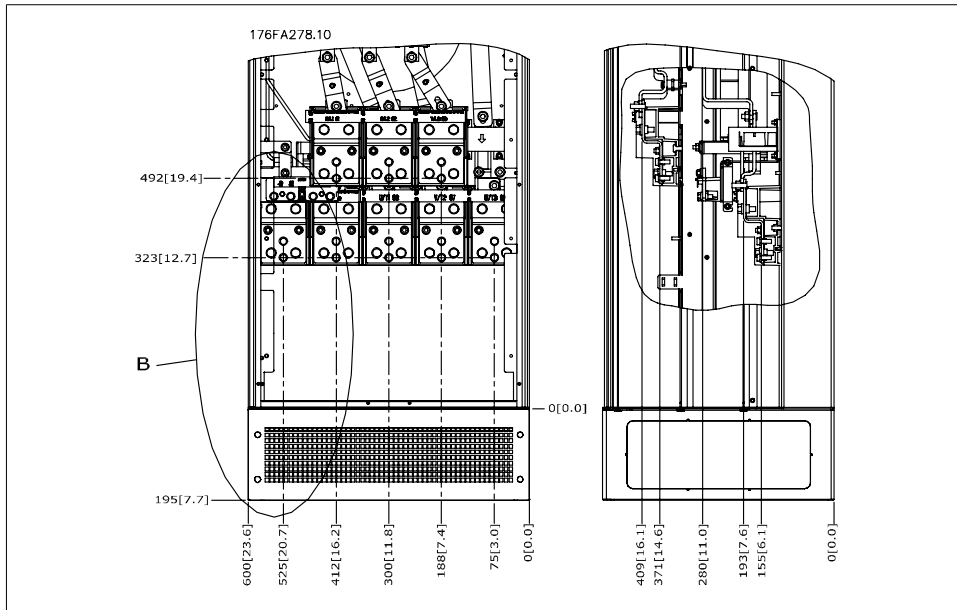

3.10: IP 21 (NEMA Type 1) and IP 54 (NEMA Type 12) enclosure power connection positions

3

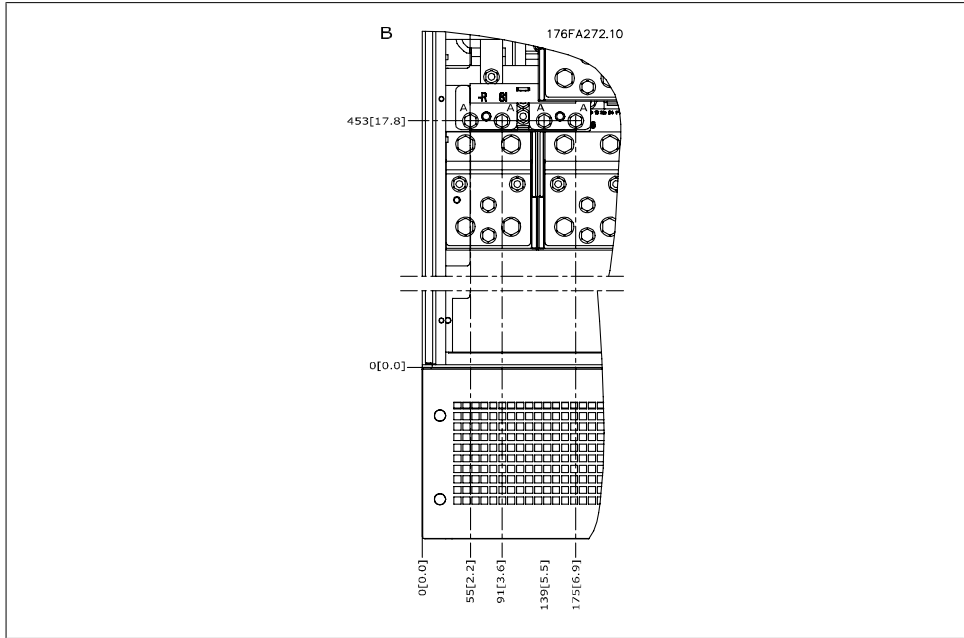

3.11: IP 21 (NEMA type 1) and IP 54 (NEMA type 12) enclosure power connection positions (detail B)

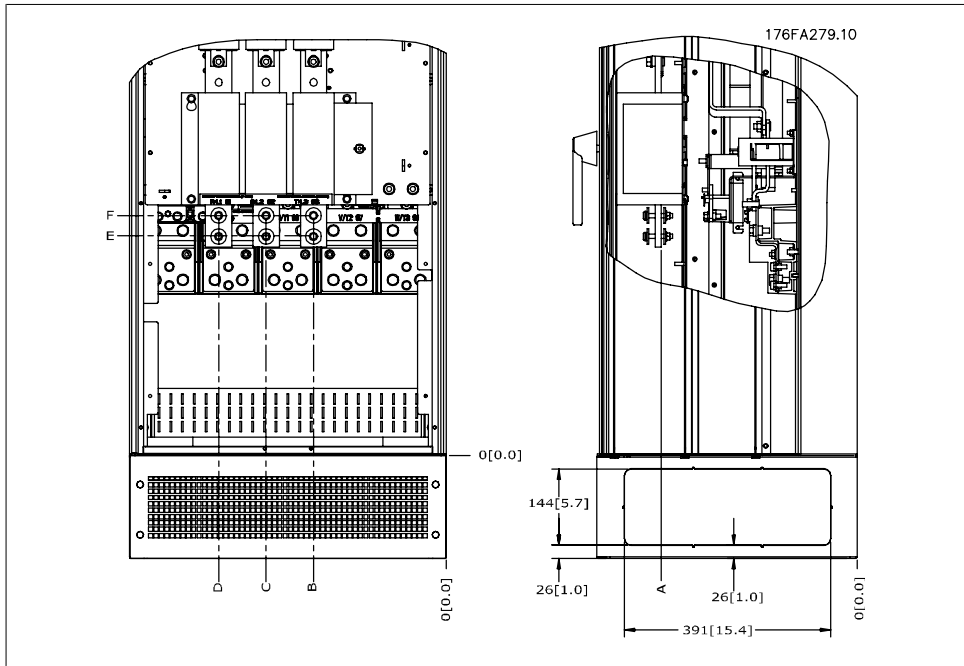

3.12: IP 21 (NEMA type 1) and IP 54 (NEMA type 12) enclosure power connection position of disconnect switch

Terminal locations - E2 enclosures

Give thought to the following terminal positions when designing the cable access.

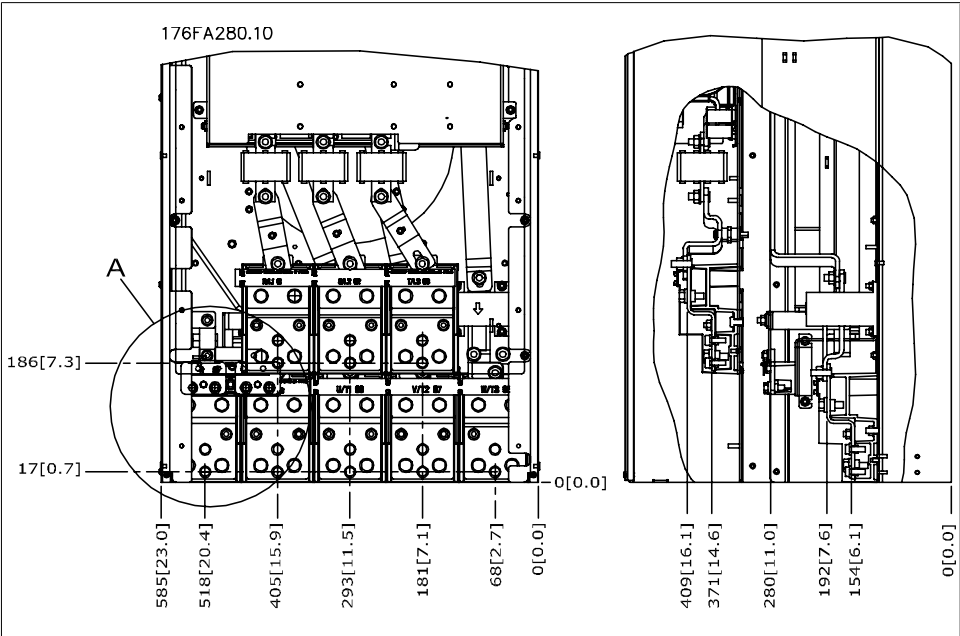

3.13: IP 00 enclosure power connection positions

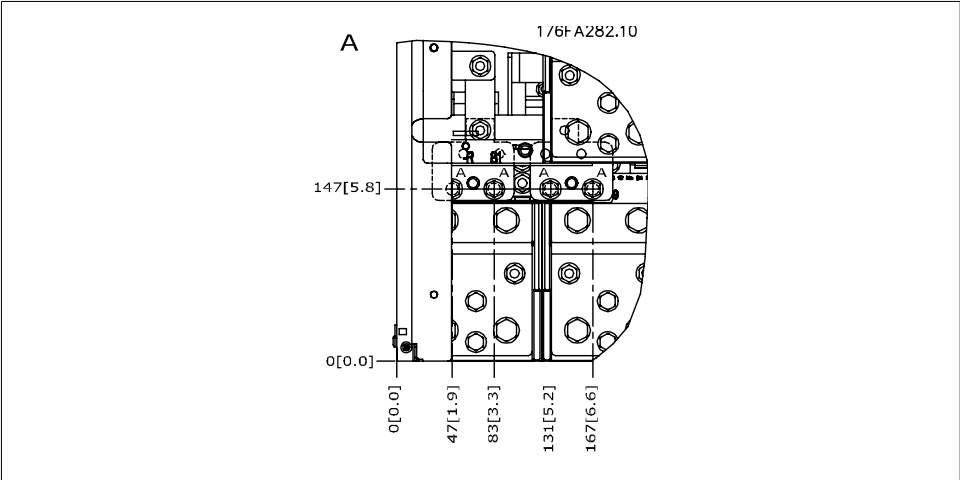

3.14: IP 00 enclosure power connection positions

3

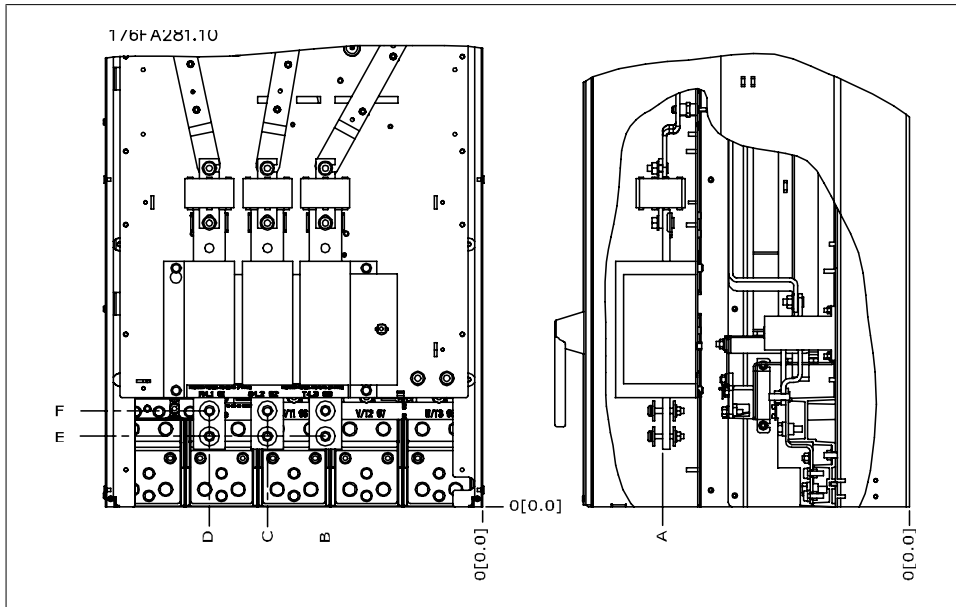

3.15: IP 00 enclosure power connections positions of disconnect switch

Note that the power cables are heavy and difficult to bend. Give thought to the optimum position of the adjustable frequency drive for ensuring easy installation of the cables. Each terminal allows for the use of up to 4 cables with cable lugs or the use of standard box lug. Ground is connected to relevant termination point in the drive.

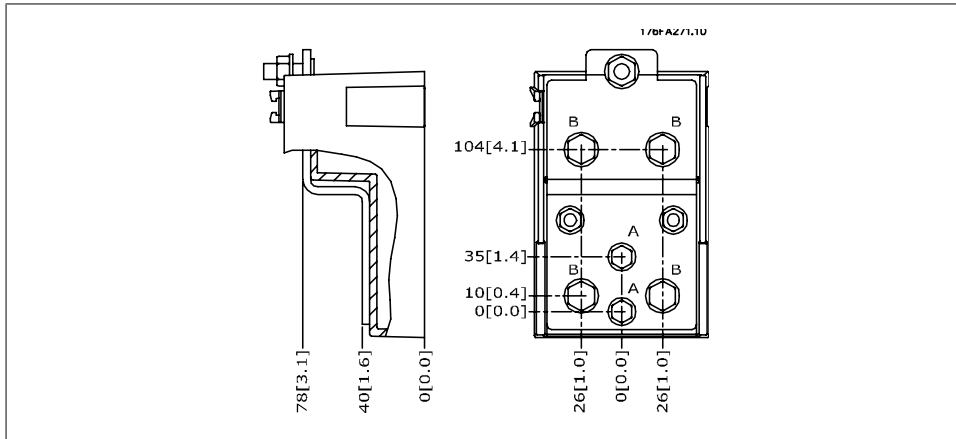

3.16: Terminal in details

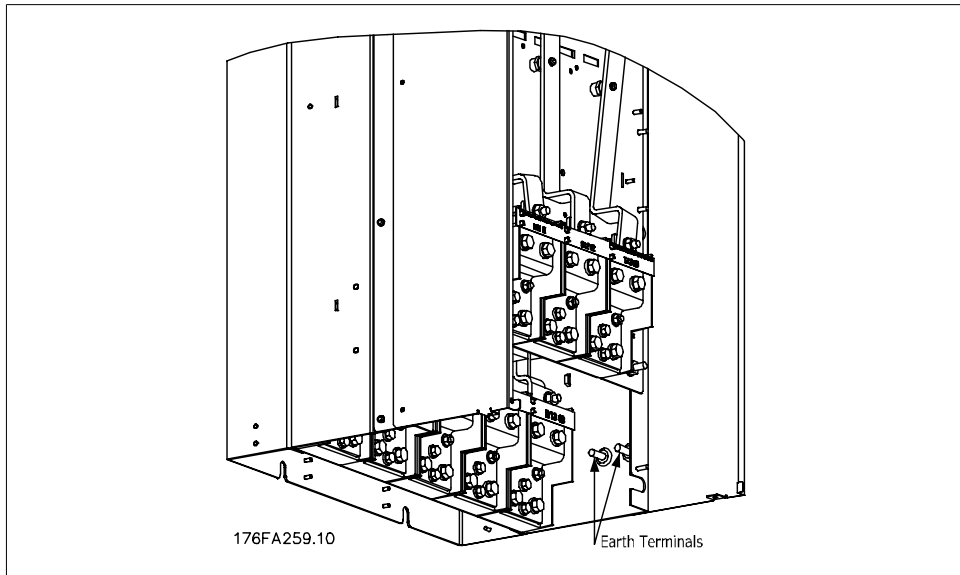

3.17: Position of ground terminals IP 00

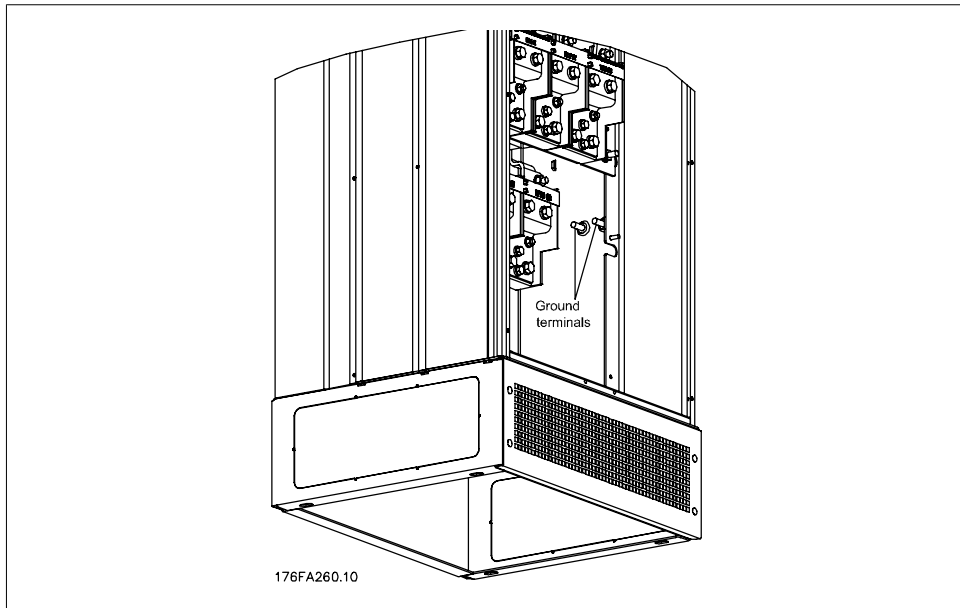

3.18: Position of ground terminals IP 21 (NEMA type 1) and IP 54 (NEMA type 12)

Cooling

Cooling can be performed in different ways: by using the cooling ducts in the bottom and the top of the unit, by using the ducts in the rear of the unit or by combining cooling options.

Airflow

The necessary airflow over the heatsink must be ensured. The flow rate is shown below.

3

Enclosure		Door fan/Top fan air-flow	Airflow over heatsink
IP 21 / NEMA 1 & IP 54 / NEMA 12	D1 and D2	6,003 ft ³ /h [170 m ³ /h] (100 cfm)	27,015 ft ³ /h [765 m ³ /h] (450 cfm)
	E1	12,006 ft ³ /h [340 m ³ /h] (200 cfm)	50994 ft ³ /h [1444 m ³ /h] (850 cfm)
IP 00 / Chassis	D3 and D4	9,005 ft ³ /h [255 m ³ /h] (150 cfm)	27,015 ft ³ /h [765 m ³ /h] (450 cfm)
	E2	9,005 ft ³ /h [255 m ³ /h] (150 cfm)	50994 ft ³ /h [1444 m ³ /h] (850 cfm)

3.2: Heatsink Air Flow

Duct cooling

A dedicated option has been developed to optimize installation of IP00 / Chassis enclosed adjustable frequency drives in Rittal TS8 enclosures utilizing the fan of the adjustable frequency drive for forced cooling.

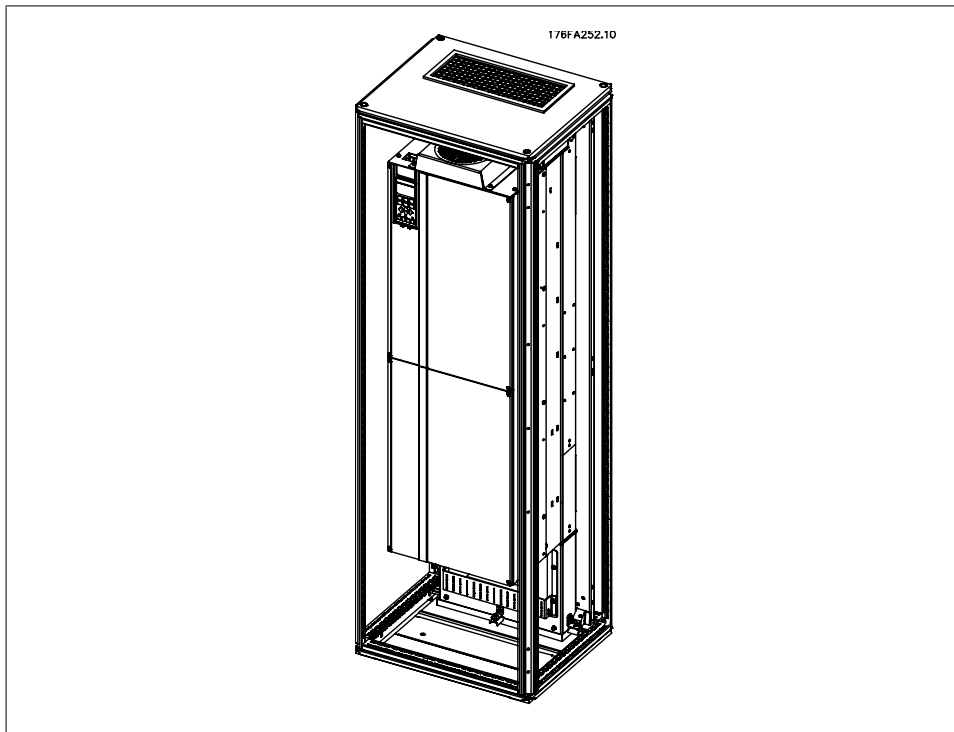

3.19: Installation of IP 00 in Rittal TS8 enclosure

Rittal TS8 Enclosure	Frame D3 Kit Part No.	Frame D4 Kit Part No.	Frame E2 Part No.
70.9 in [1800 mm]	176F1824	176F1823	Not possible
78.7 in [2000 mm]	176F1826	176F1825	176F1850
86.6 in [2200 mm]			176F0299

3.3: Duct Kit Ordering Numbers

Back cooling

Using the channel from the back allows for easy installation in control rooms, for example. The unit mounted at the rear of the enclosure allows for the cooling of the units just as easily as the duct cooling principle. The hot air is ventilated out of the back of the enclosure. This offers a solution in which the hot cooling air from the adjustable frequency drive does not cause the control room to heat up.



NOTE

A small door fan is required on the Rittal cabinet to provide additional cooling within the drive.

3

3.20: Combined use of cooling principles

The above mentioned solution can of course also be combined for an optimized solution in the actual installation.

Please see the Duct Kit Instruction Manual, 175R5640, for further information.

3.4.3. Installation in Enclosures - IP 00 / Chassis units

Since the IP 00 version is intended for panel mounting, it is important to know how to install the adjustable frequency drive and use the options available for cooling the units. A detailed description of how to install the adjustable frequency drive in a Rittal TS8 enclosure using the installation kit can be found in a later section of this Installation Guide. This can also be used as a guide for other installations.

3.4.4. Installation on the Wall - IP 21 (NEMA 1) and IP 54 (NEMA 12) Units

This only applies for D1 and D2 enclosures.

Thought must be given to where the unit should be installed.

Take the relevant points into consideration before you select the final installation site:

- Clearance space for cooling
- Clearance for opening the door
- Cable entry clearance from the bottom

3

Mark the mounting holes carefully using the mounting template on the wall, and drill the holes as indicated. Ensure proper distance to the floor and the ceiling for cooling. A minimum of 8.9 in [225 mm] below the adjustable frequency drive is needed. Mount the bolts at the bottom and lift the adjustable frequency drive up on the bolts. Tilt the adjustable frequency drive against the wall and mount the upper bolts. Tighten all four bolts to secure the adjustable frequency drive against the wall.

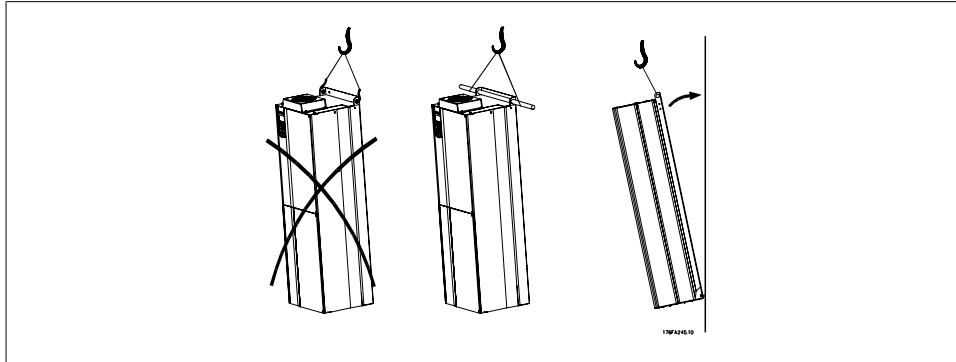

3.21: Lifting method for mounting drive on wall

3.4.5. Floor Mounting - Pedestal Installation IP 21 (NEMA1) and IP 54 (NEMA12)

IP 21 (NEMA type 1) and IP 54 (NEMA type 12) enclosed adjustable frequency drives can also be installed on a pedestal.

D1 and D2 enclosures

Ordering No. 176F1827

Please see the Pedestal Kit Instruction Manual, 175R5642, for further information.



3.22: Drive on pedestal

3

The E1 enclosure is always delivered with a pedestal as standard. Install the pedestal on the floor. Fixing holes are to be drilled according to this figure:

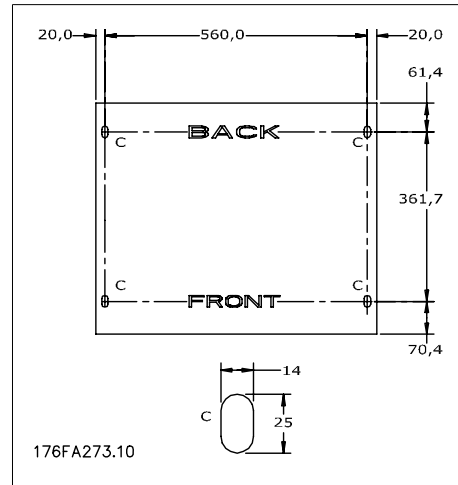

3.23: Drill master for fixing holes in floor.

Mount the drive on the pedestal and using the enclosed bolts, attach it to the pedestal, as shown in the illustration.

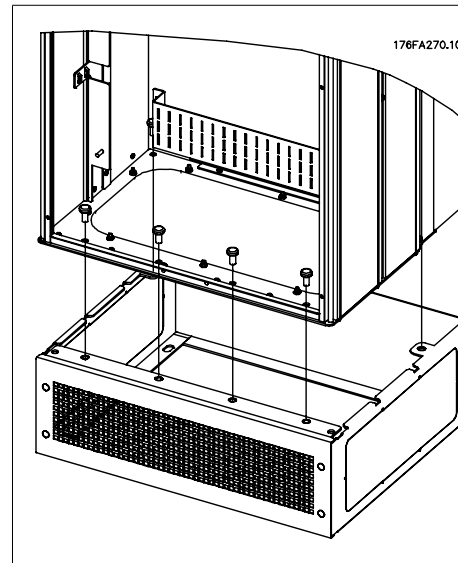

3.24: Mounting the drive to the pedestal

3

3.4.6. Gland/Conduit Entry - IP 21 (NEMA 1) and IP 54 (NEMA12)

Cables are connected through the gland plate from the bottom. Remove the plate and plan where to place the entry for the glands or conduits. Prepare holes in the marked area on the drawing.

The gland plate must be fitted to the adjustable frequency drive to ensure the specified protection degree, as well as ensuring proper cooling of the unit. If the gland plate is not mounted, it may trip the unit.

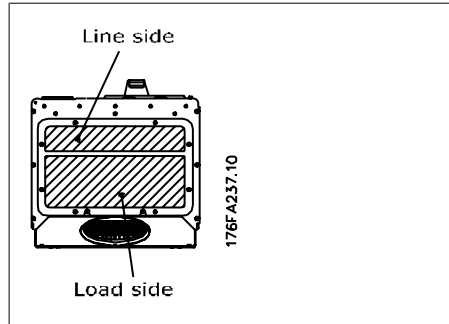

3.25: Cable entry viewed from the bottom of the adjustable frequency drive - Enclosure D1 and D2.

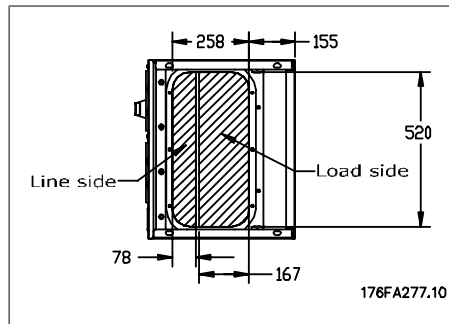

3.26: Cable entry seen from the bottom of the adjustable frequency drive - Enclosure E1.

The bottom plate of the E1 enclosure can be mounted from either in or outside of the enclosure, allowing flexibility in the installation process, i.e., if mounted from the bottom, the glands and cables can be mounted before the adjustable frequency drive is placed on the pedestal.

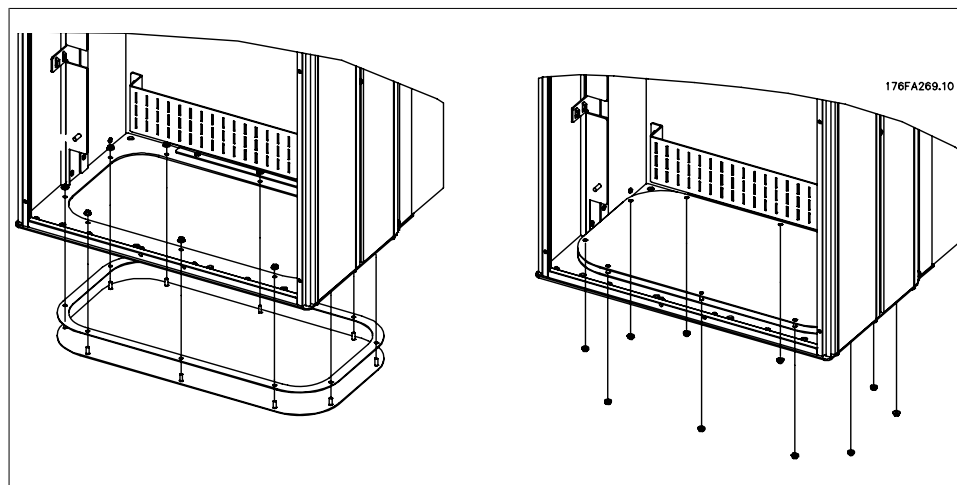

3.27: Mounting of bottom plate, E1 enclosure.

3.4.7. IP 21 Drip shield installation (D1 and D2 enclosure)

To comply with the IP 21 rating, a separate drip shield is to be installed as explained below:

- Remove the two front screws.
- Insert the drip shield and replace the screws.
- Torque the screws to 5.6 Nm (50 in-lbs).

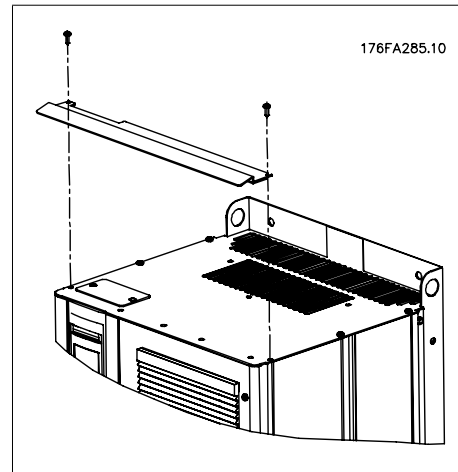

3.28: Install the drip shield.

3

3.5. Field Installation of Options

This chapter deals with the installation of IP 00/chassis-enclosed adjustable frequency drives with duct work cooling kits in Rittal enclosures. These kits are designed and tested to be used with Rittal TS8 enclosures 71 in [1,800 mm] (Frame D1 and D2 only) and 79 in [2,000 mm] height, as well as 87 in [2,200 mm] for E2 enclosures. Other enclosure heights are not supported. In addition to the enclosure, an 8 in [200 mm] base/plinth is required.

The minimum enclosure dimension is:

- D1 and D2 frame: Depth 19.7 in [500 mm] and width 23.6 in [600 mm].
- E1 frame: Depth 23.6 in [600 mm] and width 31.5 in [800 mm].

The maximum depth and width are as required for the installation. When using multiple adjustable frequency drives in one enclosure, it is recommended that each drive be mounted on its own back panel and supported along the mid-section of the panel. These duct work kits do not support the "in frame" mounting of the panel (see Rittal TS8 catalog for details). The duct work cooling kits listed in the table below are suitable for use only with IP 00/chassis adjustable frequency drives in Rittal TS8 IP 20 and UL and NEMA 1 and IP 54 and UL and NEMA 12 enclosures.

The duct work shown is for D1 and D2 enclosures. The duct work for E1 enclosures has a different appearance, but is installed in the same way.



For the E1 enclosures, it is important to mount the plate at the absolute rear of the Rittal enclosure due to the weight of the adjustable frequency drive.

Ordering Information

Rittal TS-8 Enclosure	Frame D3 Kit Part No.	Frame D4 Kit Part No.	Frame E2 Part No.
70.9 in [1800 mm]	176F1824	176F1823	Not possible
78.7 in [2000 mm]	176F1826	176F1825	176F1850
86.6 in [2200 mm]			176F0299

Kit Contents

- Ductwork components
- Mounting hardware
- Gasket material
- Delivered with D1 and D2 frame kits:
 - 175R5639 - Mounting templates and top/bottom cut-out for Rittal enclosure.
- Delivered with E1 frame kits:
 - 175R1036 - Mounting templates and top/bottom cut-out for Rittal enclosure.

All fasteners are either:

- 0.39 in [10 mm], M5 Nuts torque to 2.3 Nm (20 in-lbs)
- T25 Torx screws torque to 2.3 Nm (20 in-lbs)

3.5.1. Installation of Rittal Enclosures

This illustration shows the full size template included with the kit and two drawings that may be used to locate the cut-outs for the top and bottom enclosure plates. The duct work may also be used to locate the openings.

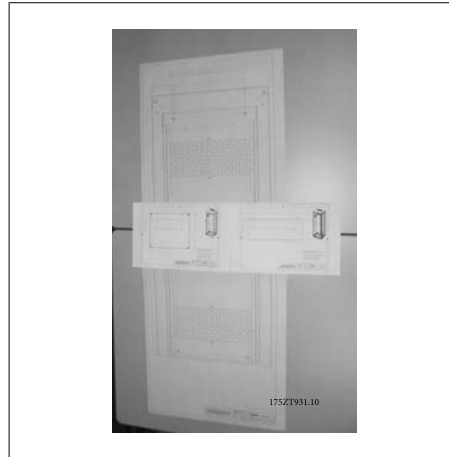

3.29: Templates

Install the gasket material on the back openings of the adjustable frequency drive prior to installation on the enclosure's back panel. Use the template provided with the kit (shown above), and install the adjustable frequency drive on the enclosure's back panel of the Rittal. The template is referenced to the top-left corner of the back panel. Therefore, the template may be used with any size back panel and both the 71 in [1800 mm] and 79 in [2000 mm] high enclosures.



3.30: The openings on the rear not used in this application.

Before installing the back panel in the enclosure, assemble the gasket on both sides of the bottom duct adapter as shown below, and install on the bottom of the adjustable frequency drive.

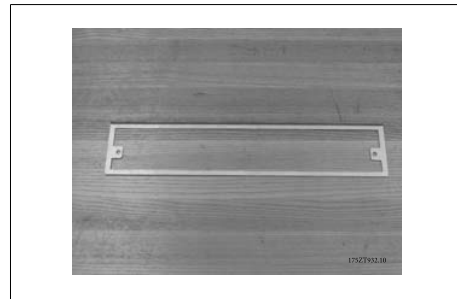

3.31: Bottom duct adapter



3.32: Bottom duct adapter with gasket installed

3



3.33: Bottom duct adapter installed

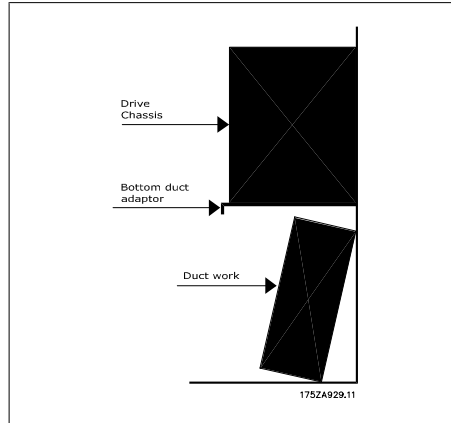

3.34: Side view

 **NOTE**
 Install the bottom plate after the adjustable frequency drive has been installed on the back to assure proper gasket coverage.

Install the two mounting brackets on the adjustable frequency drive chassis, and then install the bottom duct adapter on the bottom of the adjustable frequency drive as shown below.

The installation of the bottom plate is easier when the back panel is outside the enclosure. The curved leading edge of the bottom duct adapter is to the front of the adjustable frequency drive and down.

Before installing the back panel with the adjustable frequency drive in the Rittal TS8 enclosure, remove and discard the rearmost 5 screws (see illustration below) located on the top cover of the adjustable frequency drive. The holes will be used to fasten the top duct work with the longer screws provided with the kit.

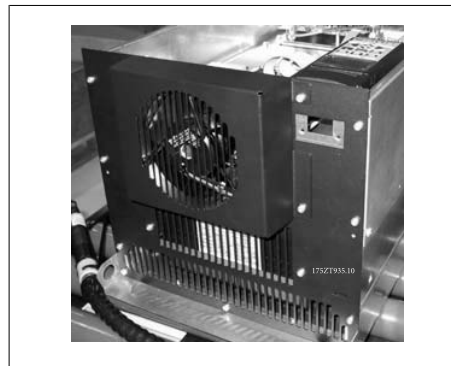

3.35: Top of IP 00/Chassis adjustable frequency drive

Install the back panel in the enclosure, see illustration below. Use Rittal PS4593.000 brackets (minimum one per side at the middle of the adjustable frequency drive) with the appropriate support strip for additional support of the back panel. For the D4 and E2 frame, use two supports per side. If additional components are mounted on the same back panel, consult the Rittal manual for additional support requirements.



3.36: Adjustable frequency drive installed in cabinet

3.5.2. Installation of Rittal Enclosures, cont.

The top ductwork cover is composed of the following pieces as shown below. From left to right: 1. top duct closing plate, 2. adjustable frequency drive bracket, 3. duct, 4. duct vented-top cover.

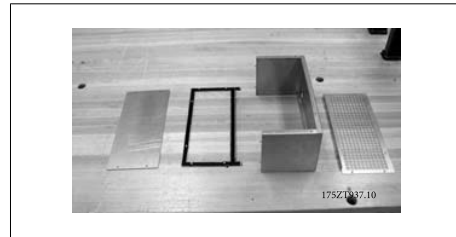

3.37: Top duct assembly



3.38: Top duct work and enclosure top installed

Temporarily install the top duct section as shown above. Use the top duct cover piece to mark the enclosure top for the opening.

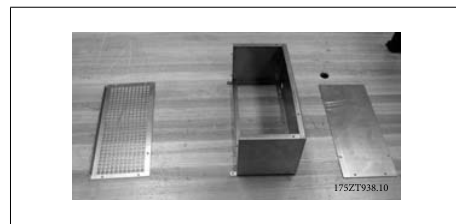

3.39: The top duct work partially assembled with adjustable frequency drive bracket

Alternatively, the mounting template (supplied drawing) can be used to make the enclosure cutout.

3



3.40: Rittal enclosure top with cut-out

The standard Rittal enclosure top is cut. The gasket is not used on the cut-out. The gasket is part of the duct work.



3.41: The gasket folds over the edge to form a seal between the duct and the top vented cover.



3.42: Top duct installed

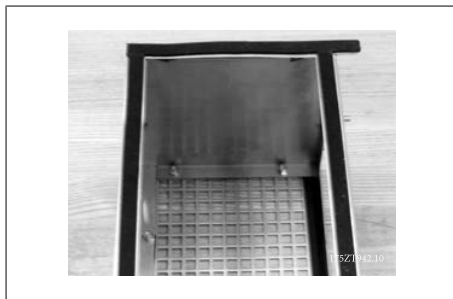

3.43: The gasket applied to both sides of the adjustable frequency drive bracket and duct vented-top cover.

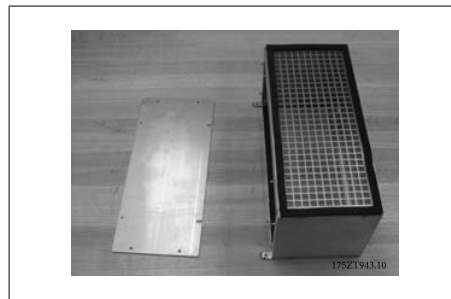

3.44: Top duct ready to be installed on the adjustable frequency drive

For the final installation of the duct work, assemble the top duct as shown below.

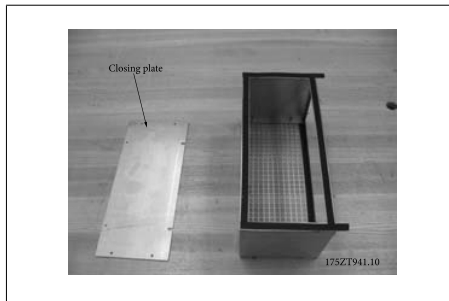

3.45: Top duct assembled with gasket

The top duct closing plate is left off for the installation of the duct work on the adjustable frequency drive. The top duct work is attached to the adjustable frequency drive using existing holes on the top cover of the adjustable frequency drive. Use the longer T25 screws provided with the kit in the existing adjustable frequency drive top cover holes. The duct work will fit over the adjustable frequency drive mounting bolts.

Once the duct work is attached to the adjustable frequency drive, the duct closing plate can be attached. The top duct work assembly is complete.

Apply the gasket to the top duct closing plate and install. Install the enclosure top. Top duct installation is complete.



3.46: Top duct installed

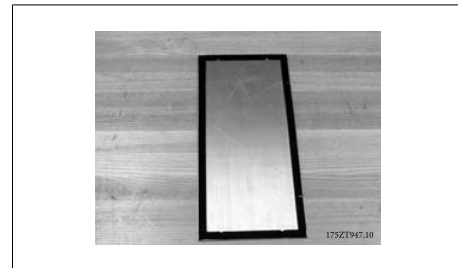

3.47: Top duct closing plate with gasket

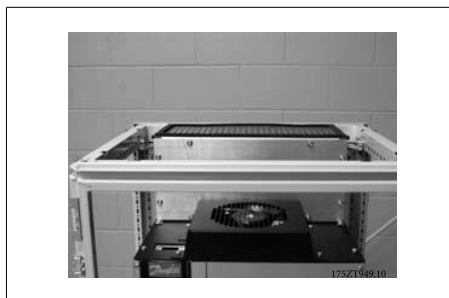

3.48: Top duct closing plate installed



3.49: Enclosure top installed



3.50: Top view of Rittal enclosure

3.5.3. Installation of Rittal Enclosures, cont.

The bottom duct assembly pieces. Refer to the drawing showing the exploded view of the duct work components. The gasket is installed as shown. Assemble the bottom duct without the cover. The assembly includes the mounting of 3 angle brackets on the front and sides of the partially assembled bottom duct. The bottom duct collar is bolted to the duct using 3 - T25 screws in the outermost holes of the brackets. Tighten the screws to compress the gasket.

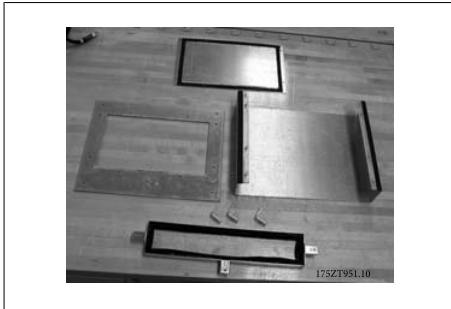

3.51: Bottom duct work pieces

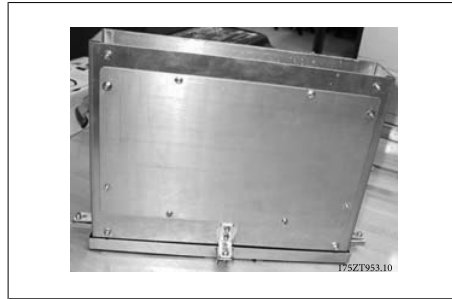

3.53: Completely assembled bottom duct work



3.52: Bottom duct work partially assembled

The duct assembly is used to mark the bottom cut-out. Temporarily install the bottom duct work as shown to the right. Use the inside of the duct work to mark the bottom of the enclosure for the opening.

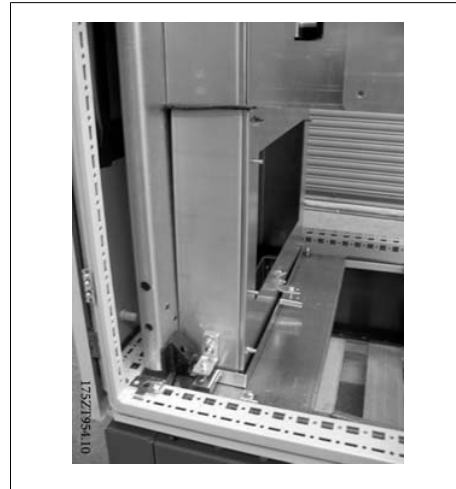

3.54: Temporarily install the duct work to mark the cut-out on the gland.

The cut-out is made on the innermost gland plate. The remaining two gland plates must be removed for the installation of the bottom duct assembly.

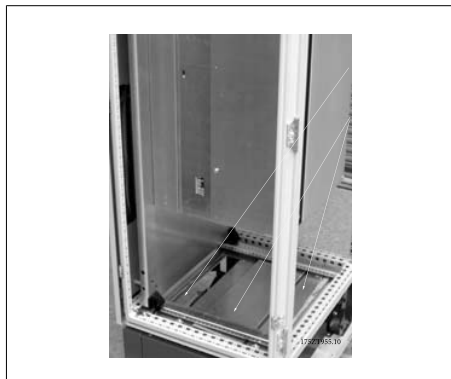

3.55: Enclosure bottom cut-out

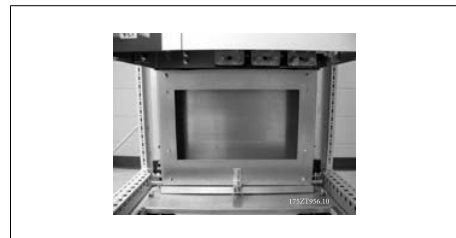

3.56: Bottom duct work installed

The bottom duct work is rotated into place as shown. The bottom ductwork is a tight fit by design. The upper part of the duct fits under the bottom duct adapter and requires a tight fit, which, with the gasket material, maintains the IP 54 and UL and NEMA 12 rating.

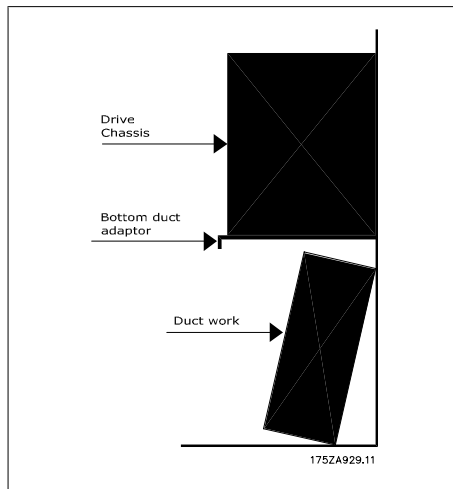

3.57: Installation of bottom duct

Install the front cover of the duct and the cable clamp base if used. Install the two remaining gland plates.

After the bottom duct work has been positioned in place, remove the three T25 screws from the outer holes in the mounting brackets on the sides and front of duct work and move them to the inner holes of the same brackets. Tighten the three screws to the specified torque. The bottom duct work is not fastened to the Rittal enclosure.



3.58: Move mounting screws from the outer hole to the inner hole

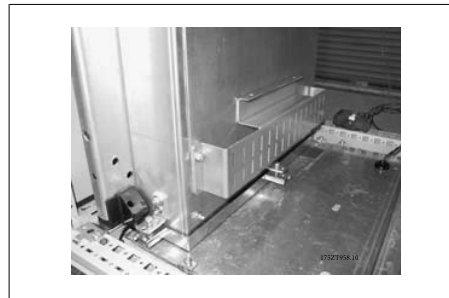

3.59: Bottom duct installed.

3.5.4. Installation on pedestal

The adjustable frequency drive can also be installed on the floor. A dedicated floor stand is designed for that purpose. It can only be used for units produced after week 50, 2004 (serial number XXXXXG504).

This section describes the installation of a pedestal unit available for the VLT series adjustable frequency drives frames D1 and D2. This is an 8 in [200 mm] high pedestal that allows these frames to be floor mounted. The front of the pedestal has openings for input air to the power components.

The adjustable frequency drive gland plate must be installed to provide adequate cooling air to the control components of the adjustable frequency drive via the door fan and to maintain the IP 21/NEMA 1 or IP 54/NEMA 12 degrees of enclosure protections.

There is one pedestal that fits both frames D1 and D2.

Required Tools:

- Socket wrench with 7-17 mm sockets
- T30 Torx Driver

Torques:

- M6 - 4.0 Nm (35 in-lbs)
- M8 - 9.8 Nm (85 in-lbs)
- M10 - 19.6 Nm (170 in-lbs)

Kit Contents:

- Pedestal parts
- Instruction Manual



3.60: Drive on pedestal.

The kit contains a U-shaped piece, a vented front cover, 2 side covers, two front brackets and the required hardware to assemble. See the exploded view of the installation, illustration "Three front screws" (drawing 130BA647).

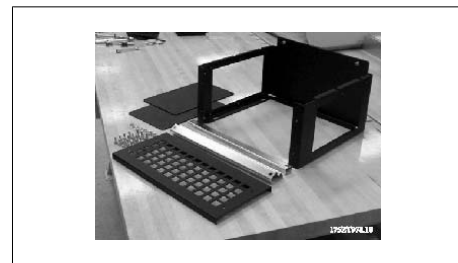

3.61: Pedestal parts

3

The pedestal has been partially assembled. Before installing the drive on to the pedestal, it is important to anchor the pedestal to the floor using the four pedestal mounting holes. The holes can accommodate up to M12 bolts (not included in the kit).

CAUTION: The drives are top heavy and may fall over if the pedestal is not anchored to the floor.

The entire assembly may also be supported by using the drive top mounting holes to anchor it to a wall structure.

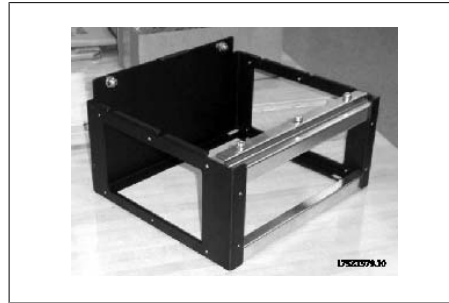

3.62: Pedestal partially assembled

The completely assembled pedestal with vented front cover and two side covers installed. Multiple adjustable frequency drives may be mounted side by side. The interior side closing plates are left off.

NOTE: The front and side cover mounting screws are now recessed M6 Torx socket flat head screws.



3.63: Final assembled pedestal.

Install the adjustable frequency drive by lowering it onto the pedestal. The adjustable frequency drive must hang over the front of the pedestal to clear the retaining bracket on the rear of the pedestal. After the adjustable frequency drive has been placed on the pedestal, slide the adjustable frequency drive so that it engages with the retaining bracket on the pedestal and mount screws as shown.

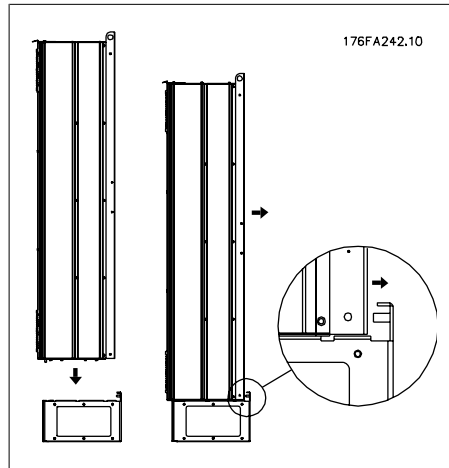

3.64: Mount the drive onto pedestal.

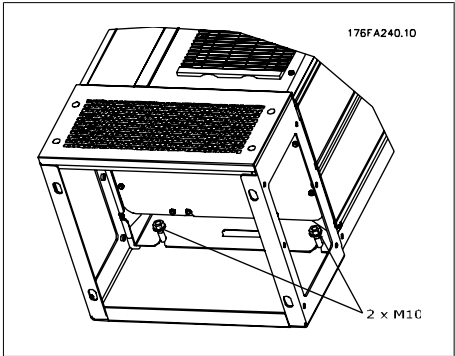

3.65: Two nuts at rear side.

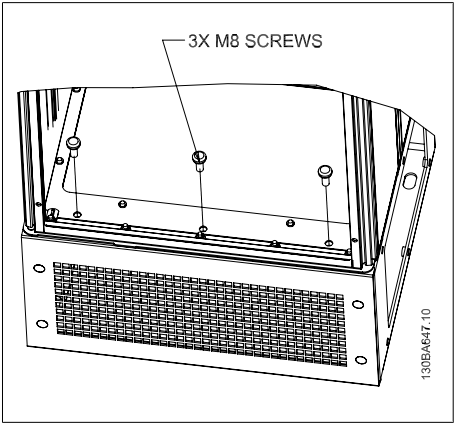

3.66: Three front screws.



3.67: Frame D2 with pedestal installed

3

3.6. Electrical Installation

3.6.1. Control Wires

3

Connect the wires as described in the Instruction Manual for the adjustable frequency drive. Remember to connect the shields properly to ensure optimum electrical immunity.

Control cable routing

Tie down all control wires to the designated control cable routing.

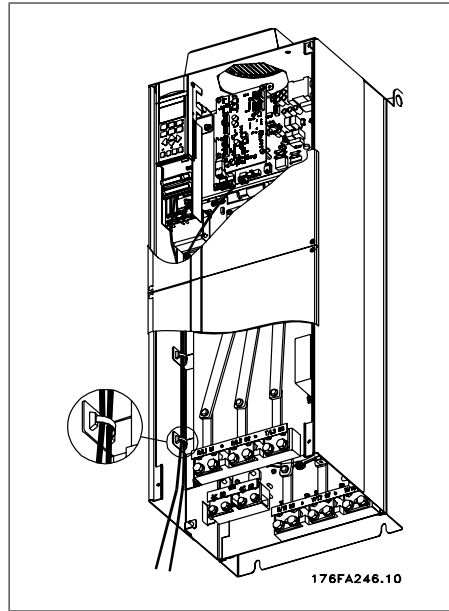

3.68: Wire path for control wiring.

Serial communication bus connection

Connections are made to the relevant options at the control card. For details, see the relevant serial communication bus instructions. The cable must be placed to the left, inside the adjustable frequency drive and tied down together with other control wires.

In the IP 00 (chassis) and IP 21 (NEMA 1) units, it is also possible to connect the serial communication bus from the top of the unit as shown on the picture below. On the IP 21 (NEMA 1), unit a cover plate must be removed.

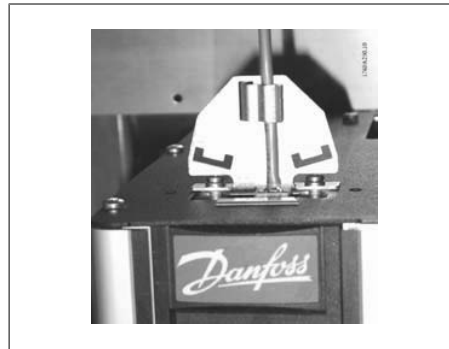

3.69: Top connection for the serial communication bus.

Installation of 24 Volt external DC Supply

Torque: 0.5 - 0.6 Nm (5 in-lbs)
Screw size: M3

No.	Function
35 (-), 36 (+)	24 V external DC supply

24 V external DC supply can be used as low-voltage supply to the control card and any option cards installed. This enables full operation of the LCP (incl. parameter setting) without connection to line power. Please note that a low voltage warning is issued when 24 V DC has been connected; however, there will be no tripping.



Use a 24 V DC supply of type PELV to ensure correct galvanic isolation (type PELV) on the control terminals of the adjustable frequency drive.

3

3.6.2. Power Connections

Cabling and Fusing



NOTE
Cables General

All cabling must comply with national and local regulations on cable cross-sections and ambient temperature. Copper (167° F [75° C]) conductors are recommended.

The power cable connections are laid out as shown below. Dimensioning of cable cross-sections must be done in accordance with the current ratings and local legislation. See the *Specifications section* for details.

To protect the adjustable frequency drive, the recommended fuses must be used or the unit must have built-in fuses. Recommended fuses are listed in the tables in the fuses section. Always ensure that proper fusing is done according to local regulations.

The line connection is fitted to the line switch if this is included.

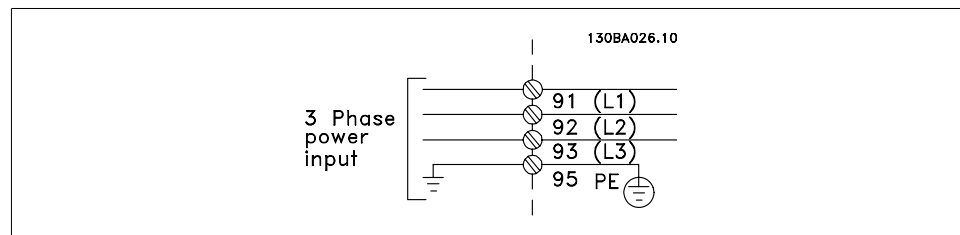

NOTE
Motor cable must be shielded/armored. The use of an unshielded/unarmored cable is against EMC requirements. Use a shielded/armored motor cable to comply with EMC emission specifications. For more information, see *EMC specifications* in the *Design Guide*.

See section General Specifications for correct dimensioning of motor cable cross-section and length.

3

Shielding of cables:

Avoid installation with twisted shield ends (pigtailed), as they reduce the shielding effect at higher frequencies. They spoil the shielding effect at higher frequencies. If it is necessary to break the shield to install a motor isolator or motor contactor, the shield must be continued at the lowest possible HF impedance.

Connect the motor cable shield to both the de-coupling plate of the adjustable frequency drive and to the metal housing of the motor.

Make the shield connections with the largest possible surface area (cable clamp). This is done by using the supplied installation devices in the adjustable frequency drive.

Cable length and cross-section:

The adjustable frequency drive has been tested with a given length of cable and a given cross-section of that cable. If the cross-section is increased, the cable capacitance - and thus the leakage current - may increase, thereby requiring that the cable length is reduced accordingly. Keep the motor cable as short as possible to reduce the noise level and leakage currents.

Details can be found in the relevant Design Guide.

Switching frequency:

When adjustable frequency drives are used together with sine-wave filters to reduce the acoustic noise from a motor, the switching frequency must be set according to the instructions in par. 14-01.

Term. no.	96	97	98	99	
	U	V	W	PE ¹⁾	Motor voltage 0-100% of line voltage. 3 wires out of motor
	U1 W2	V1 U2	W1 V2	PE ¹⁾	Delta-connected 6 wires out of motor
	U1	V1	W1	PE ¹⁾	Star-connected U2, V2, W2 U2, V2 and W2 to be interconnected separately.

¹⁾Protected Ground Connection

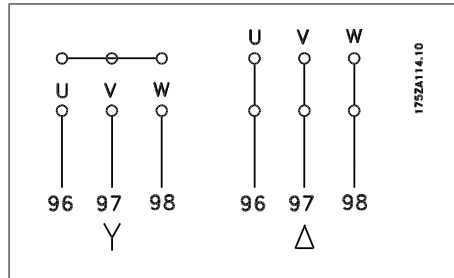

NOTE
In motors without phase insulation paper or other insulation reinforcement suitable for operation with voltage supply (such as an adjustable frequency drive), fit a sine-wave filter on the output of the adjustable frequency drive.

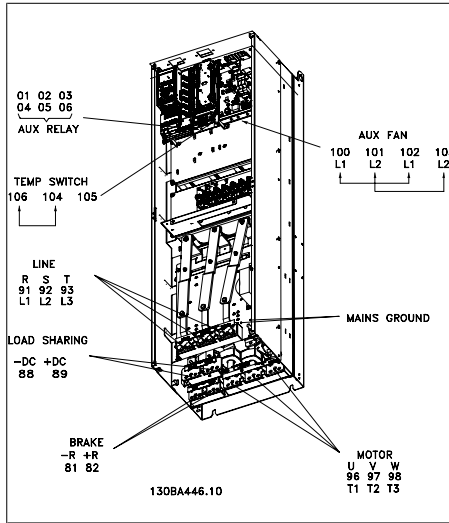

3.70: Compact IP 00 (Chassis), enclosure D3

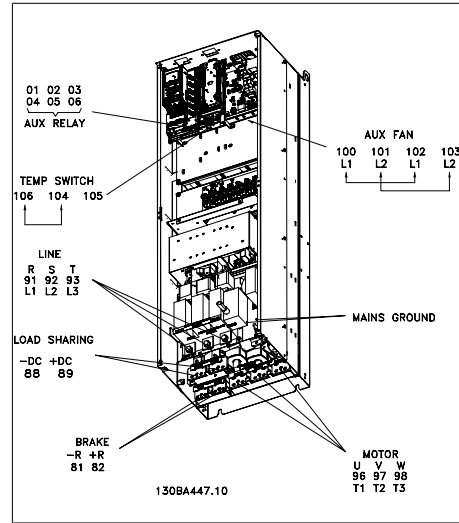

3.72: Compact IP 00 (Chassis) with disconnect, fuse and RFI filter, enclosure D4

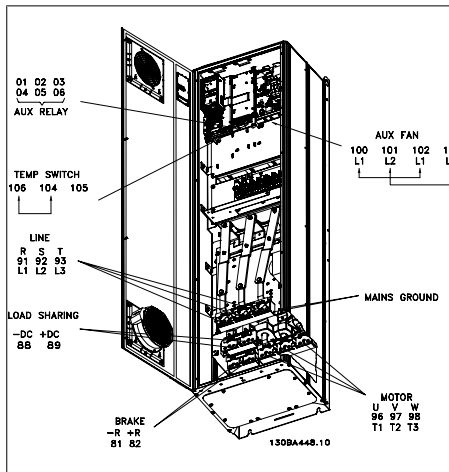

3.71: Compact IP 21 (NEMA 1) and IP 54 (NEMA 12), enclosure D1

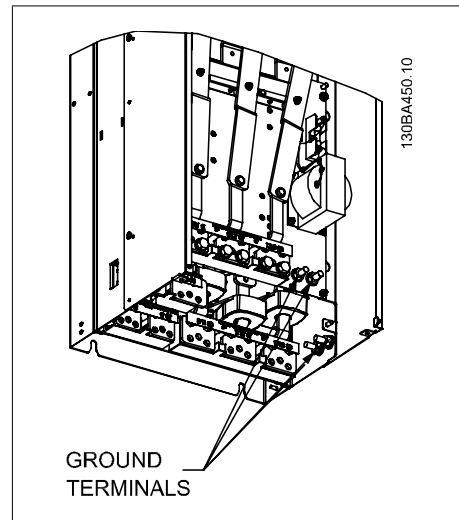

3.73: Position of ground terminals IP 00, D enclosures

3

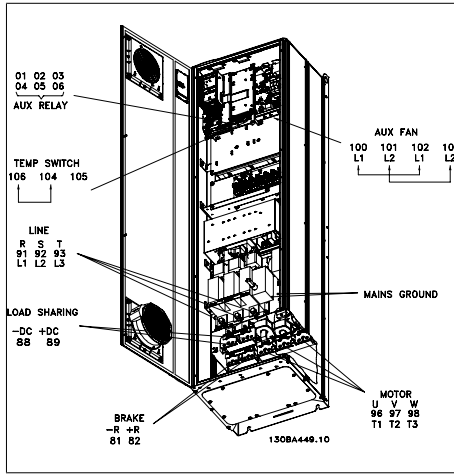

3.74: Compact IP 21 (NEMA 1) and IP 54 (NEMA 12) with disconnect, fuse and RFI filter, enclosure D2

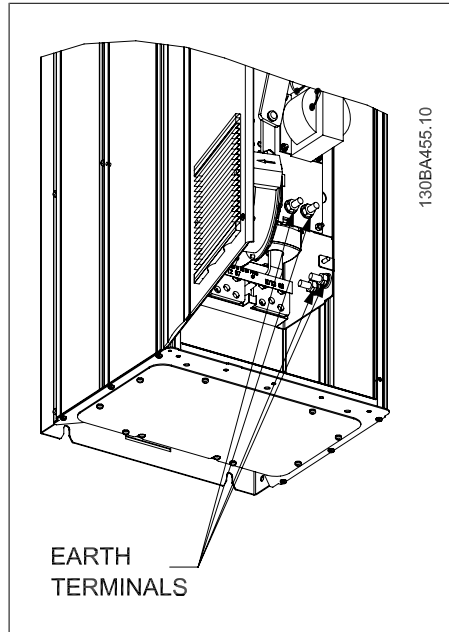

3.75: Position of ground terminals IP 21 (NEMA type 1) and IP 54 (NEMA type 12)

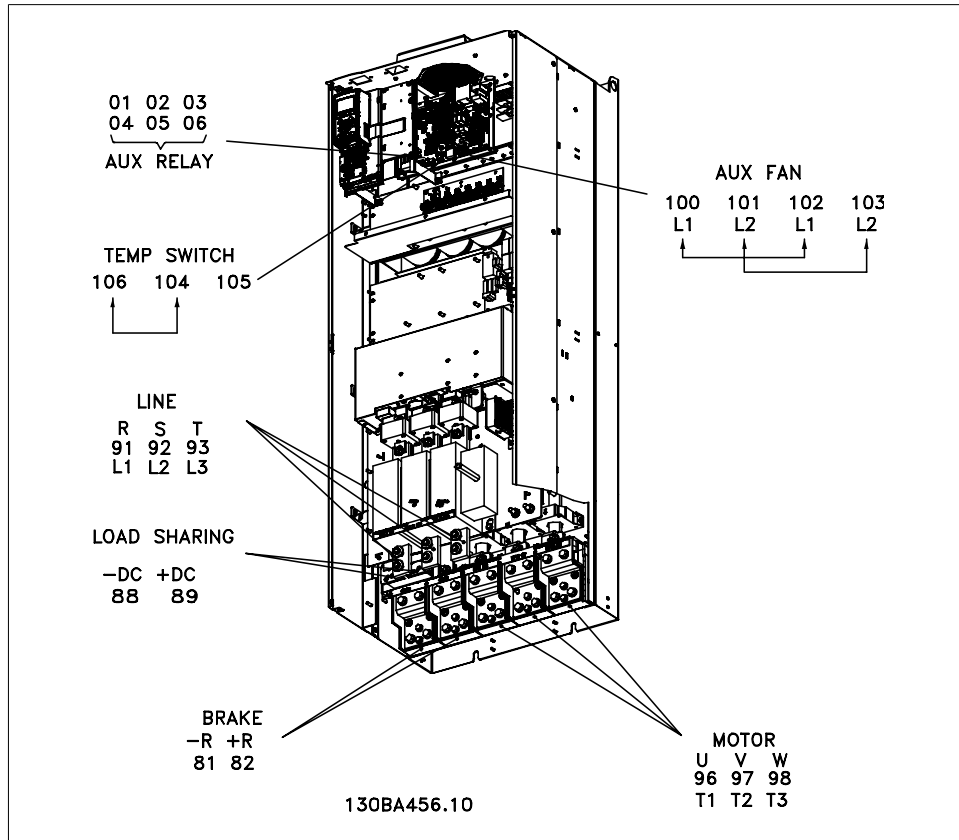

3.76: Compact IP 00 (Chassis) with disconnect, fuse and RFI filter, enclosure E2

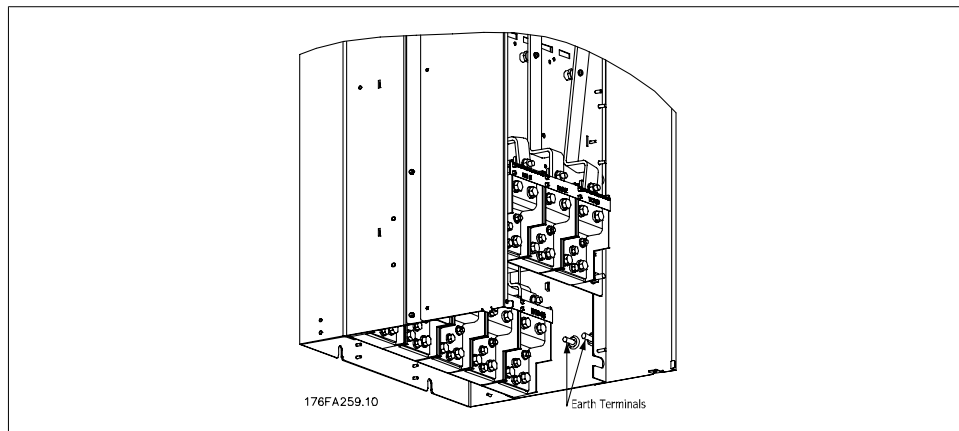

3.77: Position of ground terminals IP 00, E enclosures

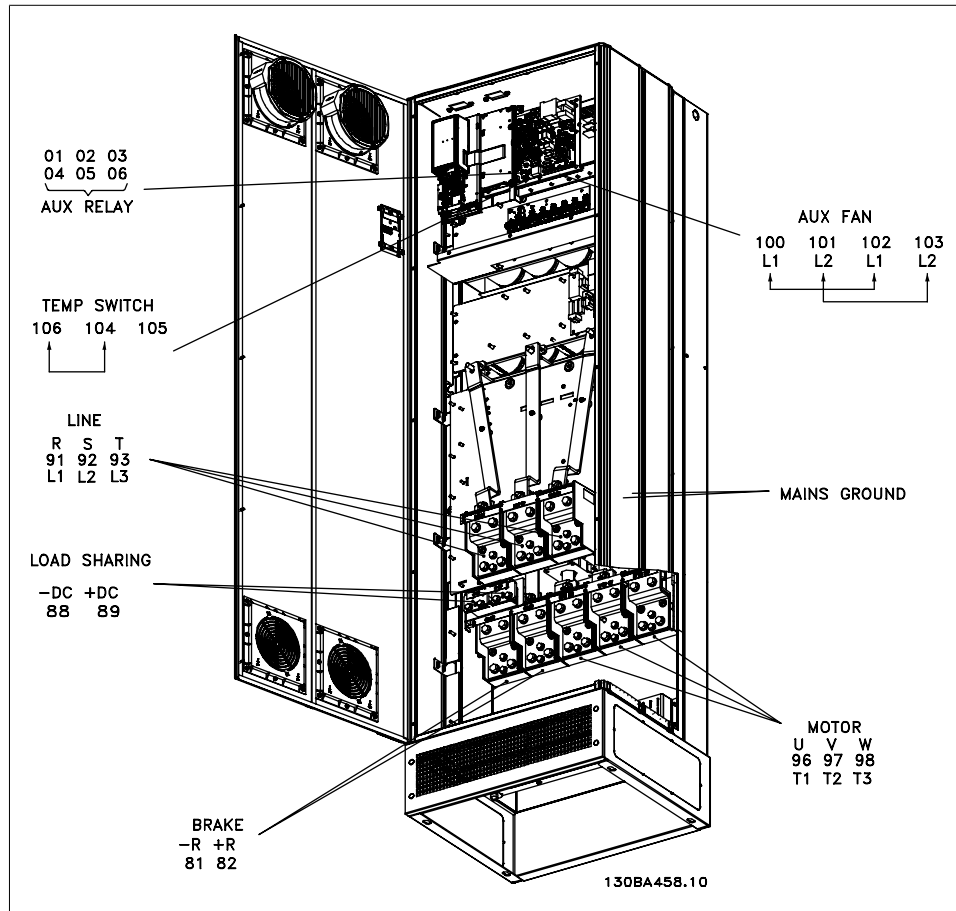

3.78: Compact IP 21 (NEMA 1) and IP 54 (NEMA 12) enclosure E1

3.6.3. Grounding

The following basic issues need to be considered when installing an adjustable frequency drive, so as to obtain electromagnetic compatibility (EMC).

- Safety grounding: Please note that the adjustable frequency drive has a high leakage current and must be grounded appropriately for safety reasons. Always follow local safety regulations.
- High-frequency grounding: Keep the ground wire connections as short as possible.

Connect the different ground systems at the lowest possible conductor impedance. The lowest possible conductor impedance is obtained by keeping the conductor as short as possible and by using the greatest possible surface area.

The metal cabinets of the different devices are mounted on the cabinet rear plate using the lowest possible HF impedance. This prevents having different HF voltages for the individual devices and prevents the risk of radio interference currents running in connection cables that may be used between the devices, as radio interference is reduced.

In order to obtain a low HF impedance, use the fastening bolts of the devices as HF connections to the rear plate. It is necessary to remove insulating paint and the like from the fastening points.

3.6.4. Extra Protection (RCD)

ELCB relays, multiple protective grounding or grounding can be used as extra protection, provided that local safety regulations are complied with.

In the case of a ground fault, a DC content may develop in the faulty current.

If ELCB relays are used, local regulations must be observed. Relays must be suitable for protection of 3-phase equipment with a bridge rectifier and for a brief discharge on power-up.

See also the section *Special Conditions* in the relevant Design Guide.

3.6.5. RFI Switch

Line supply isolated from ground

If the adjustable frequency drive is supplied from an isolated line power source (IT line power, floating delta and grounded delta) or TT/TN-S line power with grounded leg, it is recommended that the RFI switch be turned off (OFF) ¹⁾ via par. 14-50. For further reference, see IEC 364-3. If optimum EMC performance is needed, parallel motors are connected or the motor cable length is above 82 ft [25 m], it is recommended to set par. 14-50 to [ON].

¹⁾ Not required with 525-600/690 V drives; therefore not possible.

In OFF, the internal RFI capacities (filter capacitors) between the chassis and the intermediate circuit are cut off to avoid damage to the intermediate circuit and to reduce the ground capacity currents (according to IEC 61800-3).

Please also refer to the application note *VLT on IT line power*, MN.90.CX.02. It is important to use isolation monitors that are capable of being used with power electronics (IEC 61557-8).

3.6.6. Torque

When tightening all electrical connections, it is very important to tighten with the correct torque. Too low or too high torque results in a bad electrical connection. Use a torque wrench to ensure correct torque.

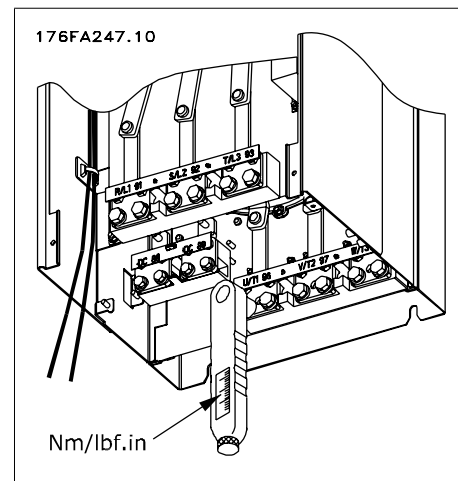

3.79: Always use a torque wrench to tighten the bolts.

Enclosure	Terminal	Torque	Bolt size
D1, D2, D3 and D4	Line Power	19 Nm (168 in-lbs)	M10
	Motor		
	Load sharing Brake	9.5 (84 in-lbs)	M8
E1 and E2	Line Power	19 NM (168 in-lbs)	M10
	Motor		
	Load sharing		
	Brake	9.5 (84 in-lbs)	M8

3.4: Torque for terminals

3.6.7. Shielded Cables

It is important that shielded and armored cables are connected properly to ensure high EMC immunity and low emissions.

Connection can be made with either cable glands or clamps:

- EMC cable glands: generally available cable glands can be used to ensure an optimum EMC connection.
- EMC cable clamp: Clamps allowing for easy connection are supplied with the adjustable frequency drive.

3.6.8. Motor cable

The motor must be connected to terminals U/T1/96, V/T2/97, W/T3/98. Ground to terminal 99. All types of three-phase asynchronous standard motors can be used with an adjustable frequency drive unit. The factory setting is for clockwise rotation with the VLT adjustable frequency drive output connected as follows:

Terminal No.	Function
96, 97, 98, 99	Line power U/T1, V/T2, W/T3 Ground/Earth

- Terminal U/T1/96 connected to U-phase
- Terminal V/T2/97 connected to V-phase
- Terminal W/T3/98 connected to W-phase

The direction of rotation can be changed by switching two phases in the motor cable or by changing the setting of par. 4-10.

3.6.9. Brake Cable

(Only standard with letter B in position 18 of typecode).

Terminal No.	Function
81, 82	Brake resistor terminals

The connection cable to the brake resistor must be shielded. Connect the shield by means of cable clamps to the conductive back plate at the adjustable frequency drive and to the metal cabinet of the brake resistor.

Size the brake cable cross-section to match the brake torque. See also *Brake Instructions, MI.90.Fx.yy* and *MI.50.Sx.yy* for further information regarding safe installation.



Please note that voltages up to 1099 V DC, depending on the supply voltage, may occur on the terminals.

3.6.10. Load Sharing

(Only extended with letter D in position 21 of the typecode).

Terminal No.	Function
88, 89	Load sharing

The connection cable must be shielded, and the max. length from the adjustable frequency drive to the DC bar is 81 ft [25 m].

Load sharing enables the linking of the DC intermediate circuits of several adjustable frequency drives.



Please note that voltages up to 1099 V DC may occur on the terminals. Load sharing calls for extra equipment. For further information, please contact Danfoss.

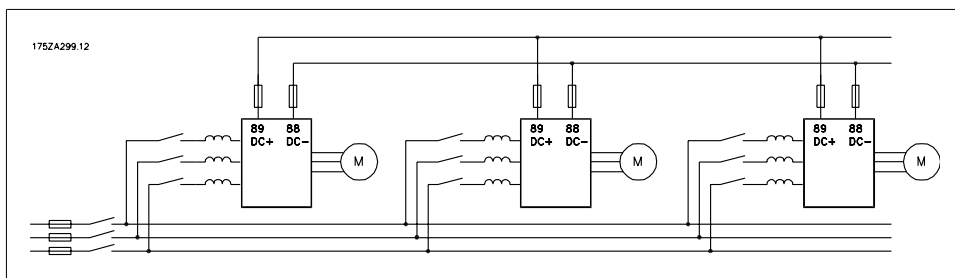

3.80: Load sharing connection

3.6.11. Shielding against Electrical Noise

Before mounting the line power cable, mount the EMC metal cover to ensure best EMC performance.

NOTE: The EMC metal cover is only included in units with an RFI filter.

3

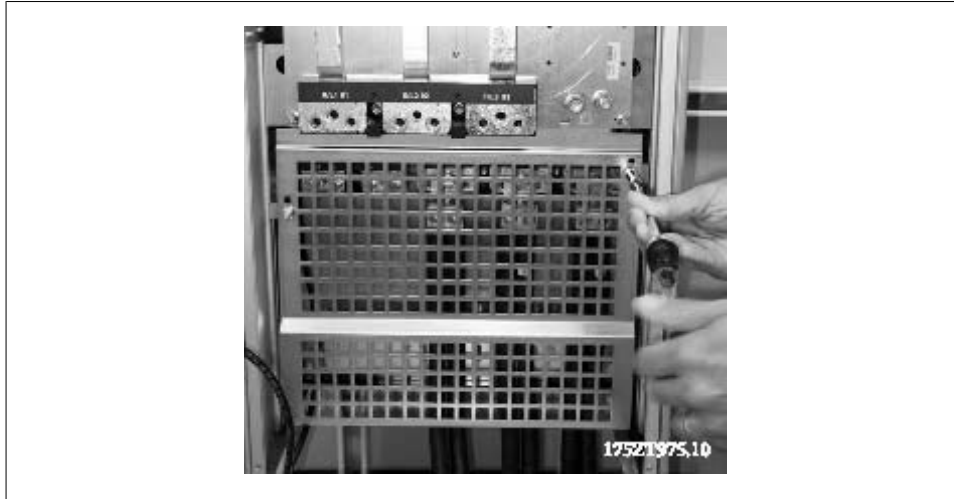

3.81: Mount the EMC shield.

3.6.12. Line connection

The line power supply must be connected to terminals 91, 92 and 93. Ground is connected to the terminal to the right of terminal 93.

Terminal No.	Function
91, 92, 93	Line power R/L1, S/L2, T/L3
94	Ground/Earth



Check the nameplate to ensure that the line voltage of the adjustable frequency drive matches the power supply of your plant.

Ensure that the power supply can supply the necessary current to the adjustable frequency drive.

If the unit is without built-in fuses, ensure that the appropriate fuses have the correct current rating.

3.6.13. External Fan Supply

If the adjustable frequency drive is supplied by DC or if the fan must run independently of the power supply, an external power supply can be applied. The connection is made to the power card.

Terminal No.	Function
100, 101	Auxiliary supply S, T
102, 103	Internal supply S, T

The connector located on the power card provides the line voltage connection for the cooling fans. The fans are factory-equipped to be supplied from a common AC line (jumpers between 100-102 and 101-103). If an external supply is needed, the jumpers are removed and the supply is connected to terminals 100 and 101. A 5 Amp fuse should be used for protection. In UL applications, this should be Littelfuse KLK-5 or equivalent.

3.6.14. Fuses

Branch circuit protection

In order to protect the installation against electrical and fire hazard, all branch circuits in an installation, switch gear, machines, etc., must be short-circuited and overcurrent protected according to national/international regulations.

Short-circuit protection

The adjustable frequency drive must be protected against short circuit in order to prevent electrical or fire hazard. Danfoss recommends using the fuses mentioned below to protect service personnel and equipment in case of an internal failure in the drive. The adjustable frequency drive provides full short-circuit protection in case of a short-circuit on the motor output.

Overcurrent protection

Provide overload protection to avoid fire hazard due to overheating of the cables in the installation. The adjustable frequency drive is equipped with an internal overcurrent protection that can be used for upstream overload protection (UL applications excluded), see par. 4-18. Moreover, fuses or circuit breakers can be used to provide the overcurrent protection in the installation. Overcurrent protection must always be carried out according to national regulations.

Fuses must be designed for protection in a circuit capable of supplying a maximum of 100,000 A_{rms} (symmetrical).

3

Fuse Tables

Size/Type	Bussmann E1958 JFHR2* *	Bussmann E4273 T/ JDDZ**	SIBA E180276 RKI/JDDZ	Littelfuse E71611 JFHR2**	Ferraz-Shawmut E60314 JFHR2**	Bussmann E4274 H/ JDDZ**	Bussmann E125085 JFHR2*	Internal Option Bussmann
P110	FWH-300	JJS-300	2028220-315	L50S-300	A50-P300	NOS-300	170M3017	170M3018
P132	FWH-350	JJS-350	2028220-315	L50S-350	A50-P350	NOS-350	170M3018	170M4016
P160	FWH-400	JJS-400	206xx32-400	L50S-400	A50-P400	NOS-400	170M4012	170M4016
P200	FWH-500	JJS-500	206xx32-500	L50S-500	A50-P500	NOS-500	170M4014	170M4016
P250	FWH-600	JJS-600	206xx32-600	L50S-600	A50-P600	NOS-600	170M4016	170M4016

3.5: D enclosures, 380-480 V

*170M fuses from Bussmann shown use the -/80 visual indicator; -TN/80 Type T, -/110 or TN/110 Type T indicator fuses of the same size and amperage may be substituted for external use
 **Any minimum 480 V UL-listed fuse with associated current rating may be used to meet UL requirements.

Size/Type	Bussmann E125085 JFHR2	Amps	SIBA E180276 JFHR2	Ferraz-Shawmut E76491 JFHR2
P110	170M3017	315	2061032.315	6.6URD30D08A0315
P132	170M3018	350	2061032.350	6.6URD30D08A0350
P160	170M4011	350	2061032.350	6.6URD30D08A0350
P200	170M4012	400	2061032.400	6.6URD30D08A0400
P250	170M4014	500	2061032.500	6.6URD30D08A0500
P315	170M5011	550	2062032.550	6.6URD32D08A0550

3.6: D enclosures, 525-690 V

Size/Type	Bussmann PN*	Danfoss PN	Rating	Losses (W)
P315	170M5013	20221	900 A, 700 V	120
P355	170M6013	20221	900 A, 700 V	120
P400	170M6013	20221	900 A, 700 V	120
P450	170M6013	20221	900A, 700 V	120

3.7: E enclosures, 380-480 V

*170M fuses from Bussmann shown use the -/80 visual indicator; -TN/80 Type T, -/110 or TN/110 Type T indicator fuses of the same size and amperage may be substituted for external use.

Danfoss PN	Bussmann	Ferraz	Siba
20220	170M4017	6.9URD31D08A0700	20 610 32.700
20221	170M6013	6.9URD33D08A0900	20 630 32.900

3.8: Additional Fuses for Non-UL Applications, E enclosures, 380-480 V

Size/Type	Bussmann PN*	Danfoss PN	Rating	Losses (W)
P355	170M4017 170M5013	20220	700 A, 700 V	85
P400	170M4017 170M5013	20220	700 A, 700 V	85
P500	170M6013	20221	900 A, 700 V	120
P560	170M6013	20221	900 A, 700 V	120

3.9: **E enclosures, 525-690 V**

*170M fuses from Bussmann shown use the -/80 visual indicator; -TN/80 Type T, -/110 or TN/110 Type T indicator fuses of the same size and amperage may be substituted for external use.

Danfoss PN	Bussmann	Ferraz	Siba
20220	170M4017	6.9URD31D08A0700	20 610 32.700
20221	170M6013	6.9URD33D08A0900	20 630 32.900

3.10: **Additional Fuses for Non-UL Applications E enclosures, 525-690 V**

Suitable for use on a circuit capable of delivering not more than 100,000 rms symmetrical amperes, 480/600/690 Volts maximum when protected by the above fuses.

Circuit Breaker Tables

Circuit Breakers manufactured by General Electric, Cat. No. SKHA36AT0800, 600 V AC maximum, with the rating plugs listed below can be used to meet UL requirements.

Size/Type	Rating plug catalog #	Amps
P110	SRPK800A300	300
P132	SRPK800A350	350
P160	SRPK800A400	400
P200	SRPK800A500	500
P250	SRPK800A600	600

3.11: **D enclosures, 380-480 V**

Non-UL compliance

If UL/cUL is not to be complied with, we recommend using the following fuses, which will ensure compliance with EN50178:

In case of malfunction, not following the recommendation may result in unnecessary damage to the adjustable frequency drive.

P110 - P200	380-480 V	type gG
P250 - P450	380-480 V	type gR

3.6.15. Brake Resistor Temperature Switch

Torque: 0.5-0.6 Nm (5 in-lbs)

Screw size: M3

This input can be used to monitor the temperature of an externally connected brake resistor. If the input between 104 and 106 opens, the adjustable frequency drive will trip on warning/alarm

27, "Brake IGBT". If the connection is closed between 104 and 105, the adjustable frequency drive will trip on warning/alarm 27, "Brake IGBT".

Normally closed: 104-106 (factory installed jumper)

Normally open: 104-105

Terminal No.	Function
106, 104, 105	Brake resistor temperature switch.



If the temperature of the brake resistor gets too high and the thermal switch drops out, the adjustable frequency drive will stop braking. The motor will start coasting. A KLIXON switch must be installed that is 'normally closed'. If this function is not used, 106 and 104 must be short-circuited together.

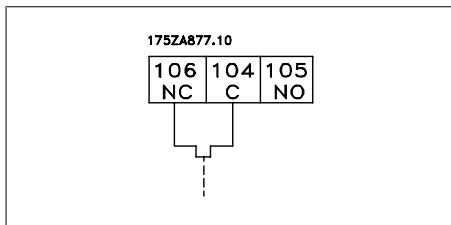

3.6.16. Access to Control Terminals

All terminals to the control cables are located beneath the LCP, accessed by opening the door of the IP 21/ 54 version or removing the covers of the IP 00 version.

3.6.17. Electrical Installation, Control Terminals

To connect the cable to the terminal:

1. Strip insulation of 0.34-0.39 in [9-10 mm]
2. Insert a screwdriver¹⁾ into the square hole.
3. Insert the cable in the adjacent circular hole.
4. Remove the screwdriver. The cable is now mounted to the terminal.

To remove the cable from the terminal:

1. Insert a screw driver¹⁾ in the square hole.
2. Pull out the cable.

¹⁾ Max. 0.015 x 0.1 in. [0.4 x 2.5 mm]

3

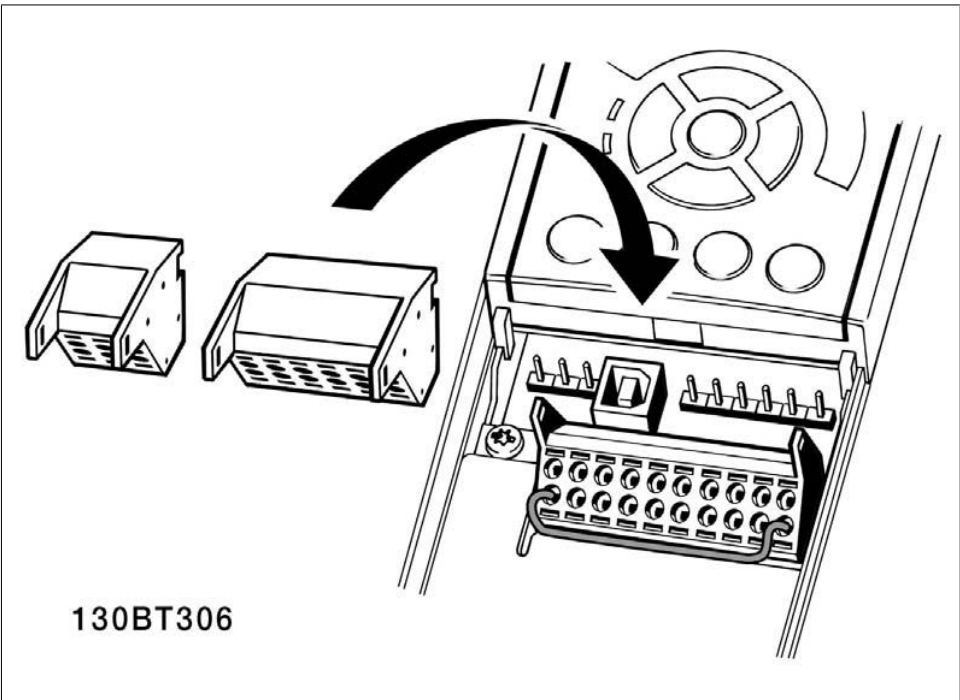
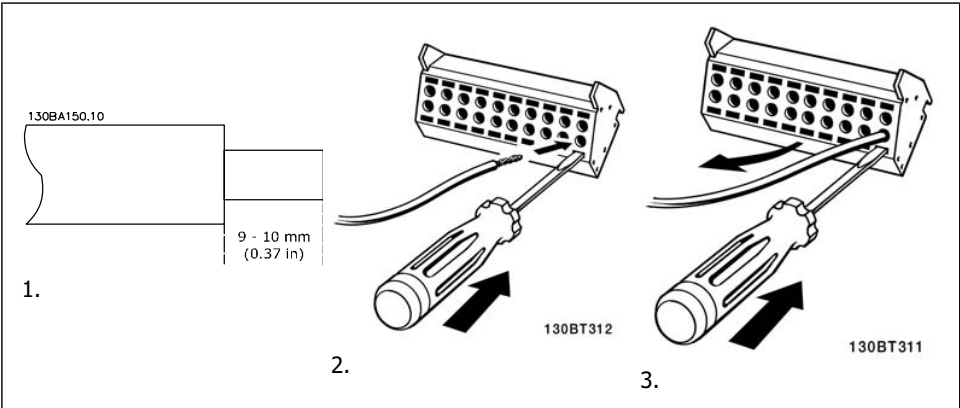

3.7. Connection Examples

3.7.1. Start/Stop

3

Terminal 18 = Par. 5-10 [8] *Start*
 Terminal 27 = Par. 5-12 [0] *No operation* (Default *coast inverse*)
 Terminal 37 = Safe stop (where available!)

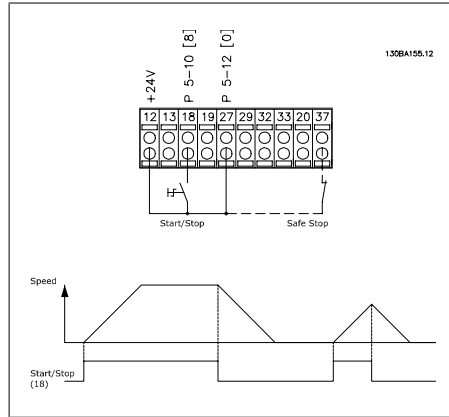

3.7.2. Pulse Start/Stop

Terminal 18 = Par. 5-10 [9] *Latched start*
 Terminal 27 = Par. 5-12 [6] *Stop inverse*
 Terminal 37 = Safe stop (where available!)

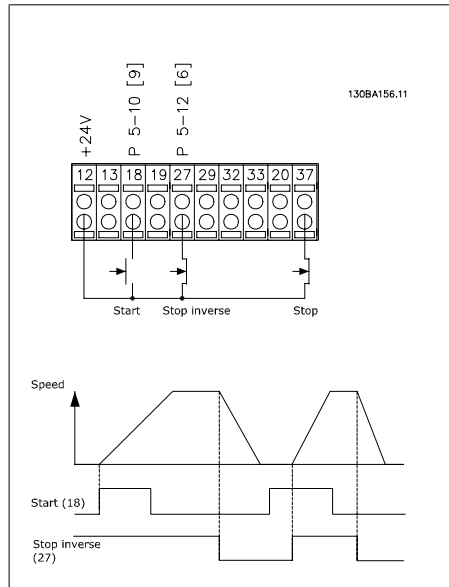

3.7.3. Speed Up/Slow

Terminals 29/32 = Speed up/Slow:

Terminal 18 = Par. 5-10 [9] *Start* (default)

Terminal 27 = Par. 5-12 [19] *Freeze reference*

Terminal 29 = Par. 5-13 [21] *Speed up*

Terminal 32 = Par. 5-14 [22] *Slow*

Note: Terminal 29 only in FC x02 (x=series type).

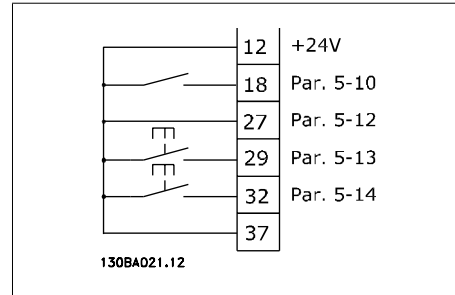

3.7.4. Potentiometer Reference

Voltage reference via a potentiometer:

Reference Source 1 = [1] *Analog input 53* (default)

Terminal 53, Low Voltage = 0 Volt

Terminal 53, High Voltage = 10 Volt

Terminal 53, Low Ref./Feedback = 0 RPM

Terminal 53, High Ref./Feedback = 1500 RPM

Switch S201 = OFF (U)

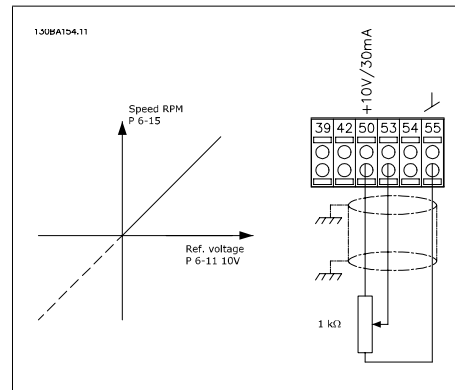

3.8. Electrical Installation - continued

3.8.1. Electrical Installation, Control Cables

3

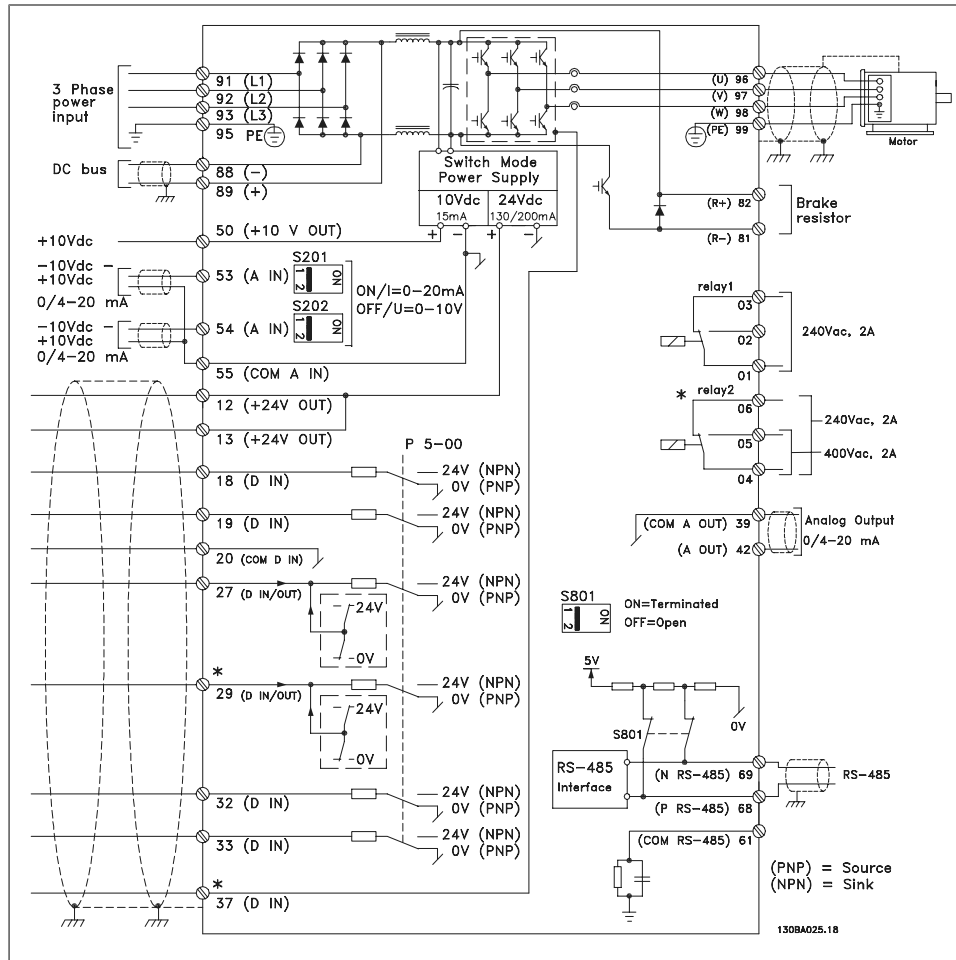

3.82: Diagram showing all electrical terminals without options.

Terminal 37 is the input to be used for Safe Stop. For instructions on safe stop installation, refer to the section *Safe Stop Installation* in the adjustable frequency drive Design Guide. See also sections *Safe Stop* and *Safe Stop Installation*.

In rare cases, very long control cables and analog signals may, depending on installation, result in 50/60 Hz ground loops due to noise from line supply cables.

If this occurs, it may be necessary to break the shield or insert a 100 nF capacitor between shield and chassis.

The digital and analog inputs and outputs must be connected separately to the adjustable frequency drive common inputs (terminal 20, 55, 39) to prevent ground currents from both groups

from affecting other groups. For example, switching on the digital input may disturb the analog input signal.

Input polarity of control terminals

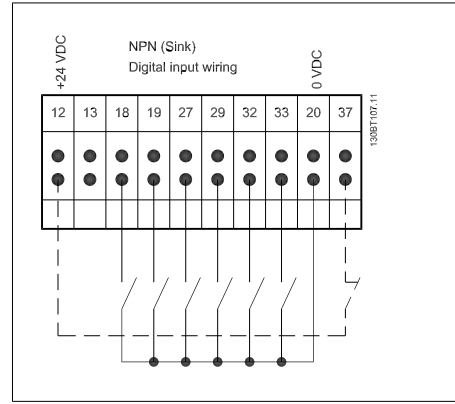
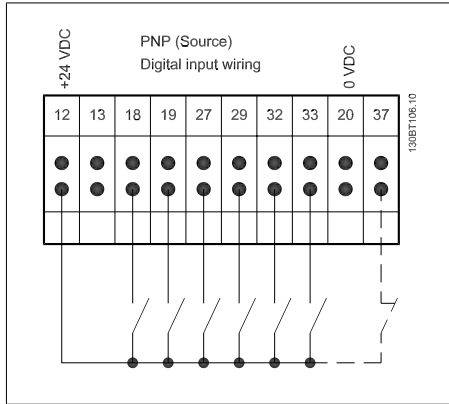

3

 **NOTE**
Control cables must be shielded/armored.

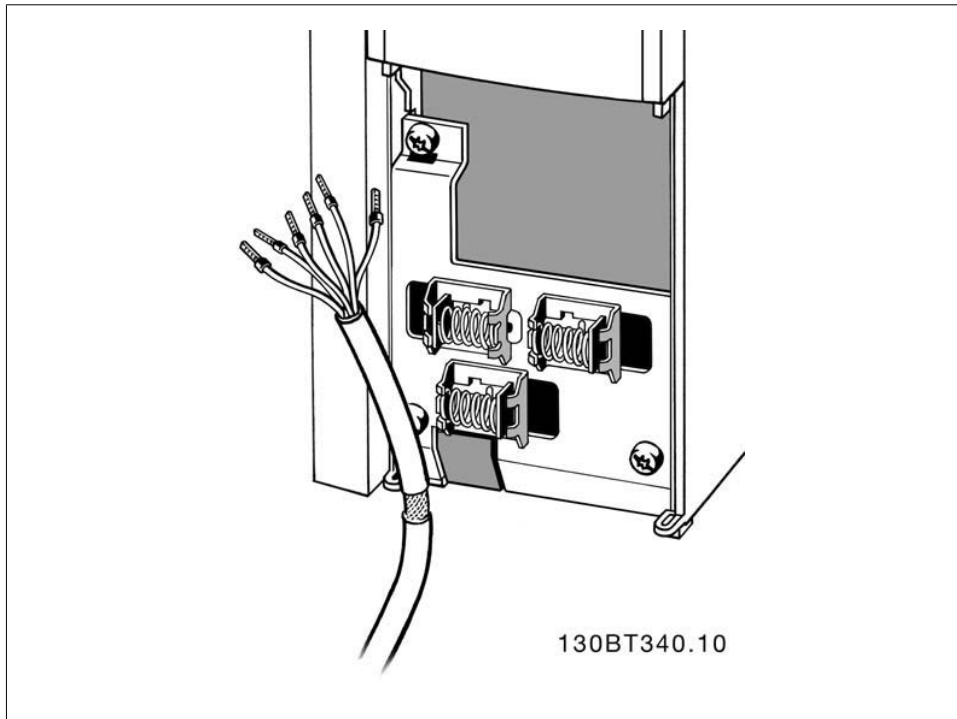

3.8.2. Switches S201, S202, and S801

Switches S201 (A53) and S202 (A54) are used to select a current (0-20 mA) or a voltage (-10 to 10 V) configuration for the analog input terminals 53 and 54, respectively.

Switch S801 (BUS TER.) can be used to enable termination on the RS-485 port (terminals 68 and 69).

See drawing *Diagram showing all electrical terminals* in section *Electrical Installation*.

Default setting:

S201 (A53) = OFF (voltage input)

S202 (A54) = OFF (voltage input)

S801 (Bus termination) = OFF



When changing the function of S201, S202 or S801, be careful not to force the switch over. Removing the LCP fixture (cradle) when operating the switches is recommended. The switches must not be operated while the adjustable frequency drive is powered.

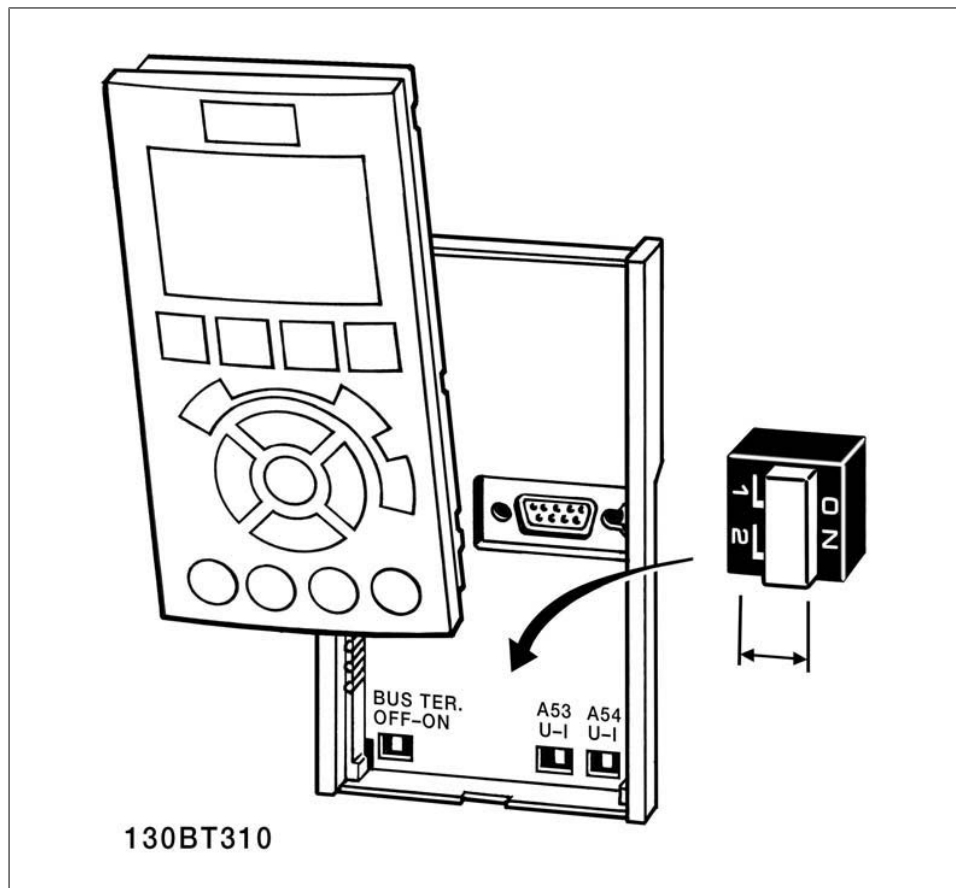

3.9. Final Set-up and Test

3.9.1. Final Set-Up and Test

To test the set-up and ensure that the adjustable frequency drive is running, follow these steps.

Step 1. Locate the motor nameplate



NOTE

The motor is either star- (Y) or delta-connected (Δ). This information is located on the motor nameplate data.

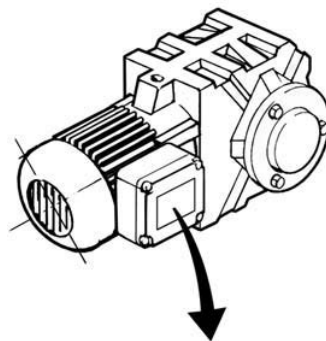

BAUER D-73734 ESILINGEN	
3 ~ MOTOR NR. 1827421	2003
S/E005A9	
	1,5 kW
n_2 31,5 /min.	400 Y V
n_1 1400 /min.	50 Hz
$\cos \varphi$ 0,80	3,6 A
1,7L	
B	IP 65 H1/1A

130BT307

Step 2. Enter the motor nameplate data in this parameter list.

To access this list, first press the [QUICK MENU] key, then select "Q2 Quick Set-up".

1.	Motor Power [kW] or Motor Power [HP]	par. 1-20 par. 1-21
2.	Motor Voltage	par. 1-22
3.	Motor Frequency	par. 1-23
4.	Motor Current	par. 1-24
5.	Motor Nominal Speed	par. 1-25

Step 3. Activate the Automatic Motor Adaptation (AMA)

Performing an AMA will ensure optimum performance. The AMA measures the values from the motor model equivalent diagram.

1. Connect terminal 37 to terminal 12 (if terminal 37 is available).
2. Connect terminal 27 to terminal 12, or set par. 5-12 to 'No function' (par. 5-12 [0]).
3. Activate the AMA par. 1-29.

4. Choose between complete or reduced AMA. If a sine-wave filter is mounted, run only the reduced AMA, or remove the sine-wave filter during the AMA procedure.
5. Press the [OK] key. The display shows "Press [Hand on] to start."
6. Press the [Hand on] key. A progress bar indicates if the AMA is in progress.

Stop the AMA during operation.

1. Press the [OFF] key. The adjustable frequency drive enters into alarm mode and the display shows that the AMA was terminated by the user.

Successful AMA

1. The display shows "Press [OK] to finish AMA."
2. Press the [OK] key to exit the AMA state.

Unsuccessful AMA

1. The adjustable frequency drive enters into alarm mode. A description of the alarm can be found in the *Warnings and Alarms* chapter.
2. "Report Value" in the [Alarm Log] shows the last measuring sequence carried out by the AMA before the adjustable frequency drive entered alarm mode. This number, along with the description of the alarm, will assist you in troubleshooting. If you contact Danfoss for service, make sure to mention the number and alarm description.



NOTE

Unsuccessful AMA is often caused by incorrectly registered motor nameplate data or a difference that is too large between the motor power size and the adjustable frequency drivepower size.

Step 4. Set speed limit and ramp time

Minimum Reference	par. 3-02
Maximum Reference	par. 3-03

3.12: Set up the desired limits for speed and ramp time.

Motor Speed Low Limit	par. 4-11 or 4-12
Motor Speed High Limit	par. 4-13 or 4-14

Ramp-up Time 1 [s]	par. 3-41
Ramp-down Time 1 [s]	par. 3-42

3.10. Additional Connections

3.10.1. Parallel Connection of Motors

The adjustable frequency drive can control several parallel-connected motors. The total current consumption of the motors must not exceed the rated output current $I_{M,N}$ for the adjustable frequency drive.



NOTE

Installation with cables connected in a common joint, as in the illustration below, is only recommended for short cable lengths.



NOTE

When motors are connected in parallel, par. 1-29 *Automatic Motor Adaptation (AMA)* cannot be used.



NOTE

The electronic thermal relay (ETR) of the adjustable frequency drive cannot be used for motor protection for the individual motor of systems with parallel-connected motors. Provide further motor protection with, for example, thermistors in each motor or individual thermal relays (circuit breakers are not suitable for protection).

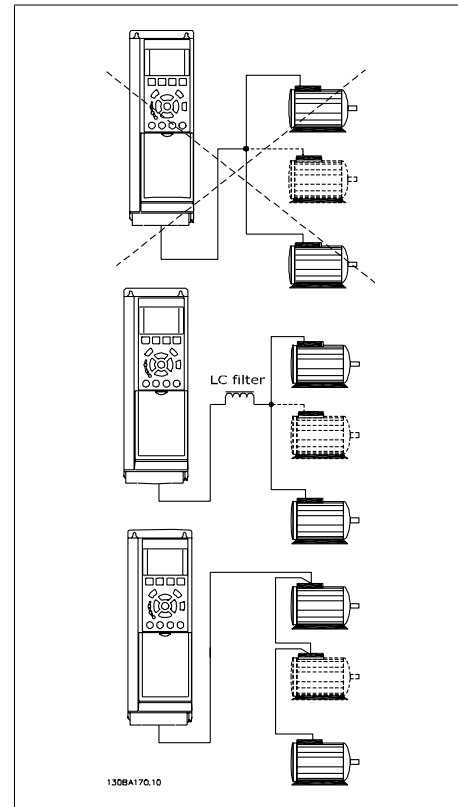

3

Problems may arise at start and at low RPM values if motor sizes are widely different because small motors' relatively high ohmic resistance in the stator calls for a higher voltage at start and at low RPM values.

3.10.2. Motor Thermal Protection

The electronic thermal relay in the adjustable frequency drive has received UL approval for single motor protection when par. 1-90 *Motor Thermal Protection* is set for *ETR Trip* and par. 1-24 *Motor current, $I_{M,N}$* is set to the rated motor current (see motor nameplate).

For thermal motor protection, it is also possible to use the MCB 112 PTC thermistor card option. This card provides an ATEX certificate to protect motors in explosion hazard areas, Zone 1/21 and Zone 2/22. Please refer to the *Design Guide* for further information.



4

4. How to program the adjustable frequency drive

4.1. How to program

4.1.1. Parameter Set-up

4

Group	Title	Function
0-	Operation/Display	Parameters related to the fundamental functions of the adjustable frequency drive, function of the LCP buttons and configuration of the LCP display.
1-	Load / Motor	Parameter group for motor settings.
2-	Brakes	Parameter group for setting brake features in the adjustable frequency drive.
3-	Reference/Ramps	Parameters for reference handling, defining limitations, and configuring the reaction of the adjustable frequency drive to changes.
4-	Limits/Warnings	Parameter group for configuring limits and warnings.
5-	Digital In/Out	Parameter group for configuring the digital inputs and outputs.
6-	Analog In/Out	Parameter group for configuring the analog inputs and outputs.
8-	Communication and Options	Parameter group for configuring communications and options.
9-	Profibus	Parameter group for Profibus-specific parameters.
10-	DeviceNet Serial Communication Bus	Parameter group for DeviceNet-specific parameters.
11-	LonWorks	Parameter group for LonWorks parameters
13-	Smart Logic	Parameter group for Smart Logic Control
14-	Special Functions	Parameter group for configuring special adjustable frequency drive functions.
15-	Drive Information	Parameter group containing adjustable frequency drive information such as operating data, hardware configuration and software versions.
16-	Data Readouts	Parameter group for data readouts, such as current references, voltages, control, alarm, warning and status words.
18-	Info and Readouts	This parameter group contains the last 10 Preventive Maintenance logs.
20-	Drive Closed-loop	This parameter group is used for configuring the closed-loop PID controller that controls the output frequency of the unit.
21-	Extended Closed-loop	Parameters for configuring the three extended closed-loop PID controllers.
22-	Application Functions	These parameters monitor water applications.
23-	Time-based Functions	These parameters are for actions to be performed on a daily or weekly basis, such as different references for working hours/non-working hours.
25-	Basic Cascade Controller Functions	Parameters for configuring the basic cascade controller for sequence control of multiple pumps.
26-	Analog I/O Option MCB 109	Parameters for configuring the Analog I/O Option MCB 109.
27-	Extended Cascade Control	Parameters for configuring the extended cascade control.
29-	Water Application Functions	Parameters for setting water specific functions.
31-	Bypass Option	Parameters for configuring the bypass option

4.1: Parameter Groups

Parameter descriptions and selections are displayed on the Graphic LCP or Numeric LCP in the display area (see Section 5 for details.) Access the parameters by pressing the [Quick Menu] or [Main Menu] key on the control panel. The quick menu is used primarily for commissioning the unit at start-up by providing those parameters necessary to commence operations. The main menu provides access to all the parameters for detailed application programming.

All digital input/output and analog input/output terminals are multifunctional. All terminals have factory default functions suitable for the majority of water applications but if other special functions are required, they must be programmed in parameter group 5 or 6.

4.1.2. Quick Menu Mode

The GLCP provides access to all parameters listed under the quick menus. The NLCP only provides access to the quick set-up parameters. To set parameters using the [Quick Menu] button:

Pressing [Quick Menu] the list indicates the different areas contained in the quick menu.

Efficient Parameter Set-up for Water Applications

The parameters can easily be set up for the vast majority of the water and wastewater applications only by using the [Quick Menu].

The best way to set parameters using the [Quick Menu] is by following the steps below:

1. Press [Quick Set-up] for selecting basic motor settings, ramp times, etc.
2. Press [Function Set-ups] for setting up the required functionality of the adjustable frequency drive - if not already covered by the settings in [Quick Set-up].
3. Choose between *General Settings*, *Open-loop Settings* and *Closed-loop Settings*.

It is recommended to do the set-up in the order listed.

Select *My Personal Menu* to display only the parameters, which have been pre-selected and programmed as personal parameters. For example, a pump or equipment OEM may have pre-programmed these to be in My Personal Menu during factory commissioning to make on-site commissioning / fine tuning simpler. These parameters are selected in parameter 0-25 *My Personal Menu*. Up to 20 different parameters can be defined in this menu.

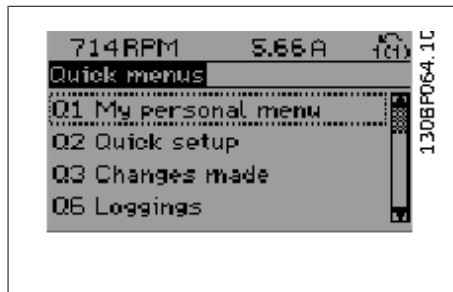

4.1: Quick menu view.

Par.	Designation	[Units]
0-01	Language	
1-20	Motor Power	[kW]
1-22	Motor Voltage	[V]
1-23	Motor Frequency	[Hz]
1-24	Motor Current	[A]
1-25	Motor Nominal Speed	[RPM]
3-41	Ramp 1 Ramp-up Time	[s]
3-42	Ramp 1 Ramp-down Time	[s]
4-11	Motor Speed Low Limit	[RPM]
4-13	Motor Speed Low High	[RPM]
1-29	Automatic Motor Adaptation	[AMA]

4.2: Quick Set-up parameters

*The display showing depends on choices made in parameter 0-02 and 0-03. The default setting of parameters 0-02 and 0-03 depends on which region of the world the adjustable frequency drive is supplied to but can be re-programmed as required.

If *No Operation* is selected in terminal 27, no connection to +24 V on terminal 27 is necessary to enable start.

If *Coast Inverse* (factory default value) is selected in Terminal 27, a connection to +24 V is necessary to enable start.

Select *Changes made* to get information about:

- The last 10 changes. Use the up/down navigation keys to scroll between the last 10 changed parameters.
- The changes made since default setting.

Select *Loggings* to get information about the display line readouts. The information is shown in graphs.

Only display parameters selected in par. 0-20 and par. 0-24 can be viewed. It is possible to store up to 120 samples in the memory for later reference.

0-01 Language**Option:****Function:**

Defines the language to be used in the display.

[0] * English UK

4

1-20 Motor Power [kW]**Range:**

Size re- [0.12-670 hp [0.09 -
lated* 500 kW]]

Function:

Enter the nominal motor power (in kW) according to the motor nameplate data. The default value corresponds to the nominal rated output of the unit.

This parameter cannot be adjusted while the motor is running. Depending on the choices made in par. 0-03 *Regional Settings*, either par. 1-20 or par. 1-21 *Motor Power* is made invisible.

1-22 Motor Voltage**Range:**

Size re- [10 - 1,000 V]
lated*

Function:

Enter the nominal motor voltage according to the motor nameplate data. The default value corresponds to the nominal rated output of the unit.

This parameter cannot be adjusted while the motor is running.

1-23 Motor Frequency**Range:**

Size re- [20 - 1000 Hz]
lated*

Function:

Select the motor frequency value from the motor nameplate data. For 87 Hz operation with 230/400 V motors, set the nameplate data for 230 V/50 Hz. Adapt par. 4-13 *Motor Speed High Limit [RPM]* and par. 3-03 *Maximum Reference* to the 87 Hz application.

This parameter cannot be adjusted while the motor is running.

1-24 Motor Current

Range: Size re- [0.1 - 10,000 A] lated*

Function: Enter the nominal motor current value from the motor nameplate data. This data is used for calculating motor torque, motor thermal protection, etc.

This parameter cannot be adjusted while the motor is running.

1-25 Motor Nominal Speed

Range: Size re- [100 - 60,000 rpm] lated*

Function: Enter the nominal motor speed value from the motor nameplate data. This data is used for calculating automatic motor compensations.

This parameter cannot be adjusted while the motor is running.

3-41 Ramp 1 Ramp-up Time

Range: 3 s* [1 - 3600 s]

Function: Enter the ramp-up time, i.e., the acceleration time from 0 rpm to the rated motor speed $n_{M,N}$ (par. 1-25). Choose a ramp-up time such that the output current does not exceed the current limit in par. 4-18 during ramping. Enter the ramp-up time, i.e., the acceleration time from 0 rpm to the rated motor speed $n_{M,N}$ (par. 1-25)

$$par.3 - 41 = \frac{t_{acc} \times n_{norm}[par.1 - 25]}{\Delta ref[rpm]} [s]$$

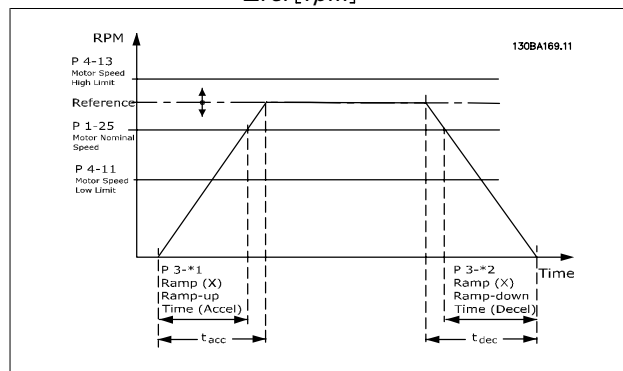

3-42 Ramp 1 Ramp-down Time

Range: 3 s* [1 - 3,600 s]

Function: Enter the ramp-down time, i.e., the deceleration time from the rated motor speed $n_{M,N}$ (par. 1-25) to 0 rpm. Choose a ramp-

down time so that no overvoltage arises in the inverter due to regenerative operation of the motor, and so that the generated current does not exceed the current limit set in par. 4-18. See ramp-up time in par. 3-41.

$$par.3 - 42 = \frac{tdec \times nnorm [par.1 - 25]}{\Delta ref [rpm]} [s]$$

4-11 Motor Speed Low Limit [RPM]

Range:

Size re-[0 - 60,000 rpm]
lated*

Function:

Enter the minimum limit for motor speed. The Motor Speed Low Limit can be set to correspond to the manufacturer's recommended minimum motor speed. The Motor Speed Low Limit must not exceed the setting in par. 4-13 *Motor Speed High Limit [RPM]*.

4-13 Motor Speed High Limit [RPM]

Range:

Size re-[0 - 60,000 rpm]
lated*

Function:

Enter the maximum limit for motor speed. The Motor Speed High Limit can be set to correspond to the manufacturer's maximum rated motor speed. The Motor Speed High Limit must exceed the setting in par. 4-11 *Motor Speed Low Limit [RPM]*. Only par. 4-11 or 4-12 will be displayed depending on other parameters set in the Main Menu, and depending on default settings specific to global geographical locations.



NOTE

The output frequency value of the adjustable frequency drive must not exceed a value higher than 1/10 of the switching frequency.

1-29 Automatic Motor Adaptation (AMA)

Option:

Function:

The AMA function optimizes dynamic motor performance by automatically optimizing the advanced motor parameters (par. 1-30 to par. 1-35) while the motor is stationary.

[0] * OFF

No function

[1] Enable complete AMA

performs AMA of the stator resistance R_s , the rotor resistance R_r , the stator leakage reactance X_{1s} , the rotor leakage reactance X_{2r} and the main reactance X_h .

[2] Enable reduced AMA

performs a reduced AMA of the stator resistance R_s in the system only. Select this option if an LC filter is used between the adjustable frequency drive and the motor.

Activate the AMA function by pressing [Hand on] after selecting [1] or [2]. See also the section *Automatic Motor Adaptation*. After a normal sequence, the display will read: "Press [OK] to finish AMA". After pressing the [OK] key, the adjustable frequency drive is ready for operation.

Note:

- For the best adaptation of the adjustable frequency drive, run the AMA on a cold motor.
- AMA cannot be performed while the motor is spinning.

NOTE
It is important to set motor par. 1-2* Motor Data correctly, since these form part of the AMA algorithm. An AMA must be performed to achieve optimum dynamic motor performance. It may take up to 10 min, depending on the power rating of the motor.

NOTE
Avoid generating external torque during AMA.

NOTE
If one of the settings in par. 1-2* Motor Data is changed, par. 1-30 to 1-39, the advanced motor parameters, will return to default setting.
This parameter cannot be adjusted while the motor is running.

See section *Automatic Motor Adaptation* - application example.

4.1.3. Function Set-ups

The function set-up provides quick and easy access to all parameters required for the majority of water and wastewater applications including variable torque, constant torque, pumps, dosing pumps, well pumps, booster pumps, mixer pumps, aeration blowers and other pump and fan applications. Among other features, it also includes parameters for selecting which variables to display on the LCP, digital preset speeds, scaling of analog references, closed-loop single zone and multi-zone applications and specific functions related to water and wastewater applications.

Example of how to access Function Set-up:

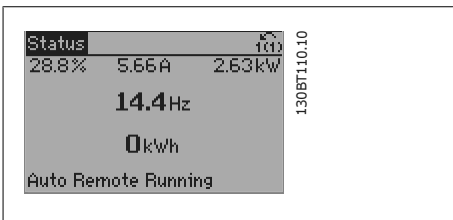

4.2: Step 1: Turn on the adjustable frequency drive (on LED lights).

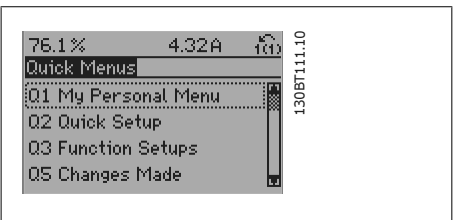

4.3: Step 2: Press the [Quick Menu] button (quick menu choices appear).

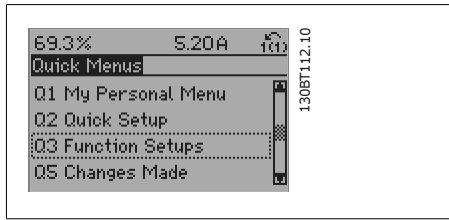

4.4: Step 3: Use the up/down navigation keys to scroll down to Function Set-ups. Press [OK].

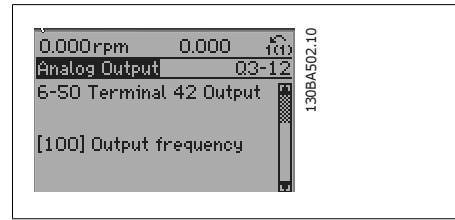

4.7: Step 6: Choose parameter 6-50 *Terminal 42 Output*. Press [OK].

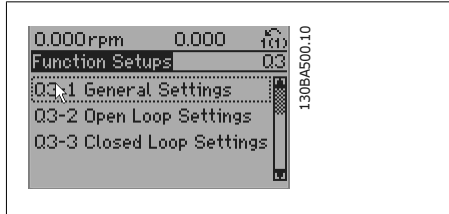

4.5: Step 4: Function Set-ups choices appear. Choose Q3-1 *General Settings*. Press [OK].

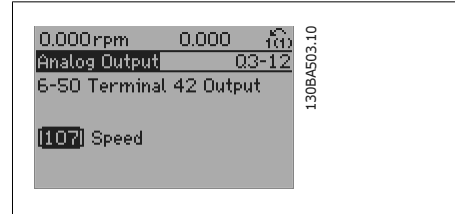

4.8: Step 7: Use the up/down navigation keys to select between the different choices. Press [OK].

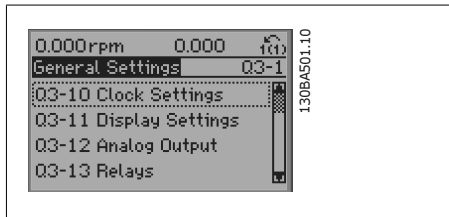

4.6: Step 5: Use the up/down navigation keys to scroll down to, e.g., Q3-12 *Analog Outputs*. Press [OK].

The Function Set-up parameters are grouped in the following way:

Q3-1 General Settings			
Q3-10 Clock Settings	Q3-11 Display Settings	Q3-12 Analog Output	Q3-13 Relays
0-70 Set Date and Time	0-20 Display Line 1.1 Small	6-50 Terminal 42 Output	Relay 1 ⇒ 5-40 Function Relay
0-71 Date Format	0-21 Display Line 1.2 Small	6-51 Terminal 42 Output Min Scale	Relay 2 ⇒ 5-40 Function Relay
0-72 Time Format	0-22 Display Line 1.3 Small	6-52 Terminal 42 Output Max Scale	Option relay 7 ⇒ 5-40 Function Relay
0-74 DST/Summertime	0-23 Display Line 2 Large		Option relay 8 ⇒ 5-40 Function Relay
0-76 DST/Summertime Start	0-24 Display Line 3 Large		Option relay 9 ⇒ 5-40 Function Relay
0-77 DST/Summertime End	0-37 Display Text 1		
	0-38 Display Text 2		
	0-39 Display Text 3		

Q3-2 Open-loop Settings	
Q3-20 Digital Reference	Q3-21 Analog Reference
3-02 Minimum Reference	3-02 Minimum Reference
3-03 Maximum Reference	3-03 Maximum Reference
3-10 Preset Reference	6-10 Terminal 53 Low Voltage
5-13 Terminal 29 Digital Input	6-11 Terminal 53 High Voltage
5-14 Terminal 32 Digital Input	6-14 Terminal 53 Low Ref/Feedb. Value
5-15 Terminal 33 Digital Input	6-15 Terminal 53 High Ref/Feedb. Value

Q3-3 Closed-loop Settings	
Q3-30 Feedback Settings	Q3-31 PID Settings
1-00 Configuration Mode	20-81 PID Normal/Inverse Control
20-12 Reference/Feedb.Unit	20-82 PID Start Speed [RPM]
3-02 Minimum Reference	20-21 Setpoint 1
3-03 Maximum Reference	20-93 PID Proportional Gain
6-20 Terminal 54 Low Voltage	20-94 PID Integral Time
6-21 Terminal 54 High Voltage	
6-24 Terminal 54 Low Ref/Feedb Value	
6-25 Terminal 54 High Ref/Feedb Value	
6-00 Live Zero Timeout Time	
6-01 Live Zero Timeout Function	

0-20 Display Line 1.1 Small

Option:	Function:
	Select a variable for display in line 1, left position.
[0] None	No display value selected
[37] Display Text 1	Present control word
[38] Display Text 2	Enables an individual text string to be written, for display in the LCP or to be read via serial communication.
[39] Display Text 3	Enables an individual text string to be written, for display in the LCP or to be read via serial communication.
[89] Date and Time Read-out	Displays the current date and time.
[953] Profibus Warning Word	Displays Profibus communication warnings.
[1005] Readout Transmit Error Counter	View the number of CAN control transmission errors since the last power-up.
[1006] Readout Receive Error Counter	View the number of CAN control receipt errors since the last power-up.
[1007] Readout Bus Off Counter	View the number of Bus Off events since the last power-up.
[1013] Warning Parameter	View a DeviceNet-specific warning word. One separate bit is assigned to every warning.
[1115] LON Warning Word	Shows the LON-specific warnings.

[1117]	XIF Revision	Shows the version of the external interface file of the Neuron C chip on the LON option.
[1118]	LON Works Revision	Shows the software version of the application program of the Neuron C chip on the LON option.
[1501]	Running Hours	View the number of running hours of the motor.
[1502]	kWh Counter	View the line power consumption in kWh.
[1600]	Control Word	View the control word sent from the adjustable frequency drive via the serial communication port in hex code.
[1601]	* Reference [Unit]	Total reference (sum of digital/analog/preset/bus/freeze ref./catch up and slow-down) in selected unit.
[1602]	Reference %	Total reference (sum of digital/analog/preset/bus/freeze ref./catch up and slow-down) as a percentage.
[1603]	Status Word	Present status word
[1605]	Main Actual Value [%]	One or more warnings in a Hex code
[1609]	Custom Readout	View the user-defined readouts as defined in par. 0-30, 0-31 and 0-32.
[1610]	Power [kW]	Actual power consumed by the motor in kW.
[1611]	Power [hp]	Actual power consumed by the motor in HP.
[1612]	Motor Voltage	Voltage supplied to the motor.
[1613]	Motor Frequency	Motor frequency, i.e., the output frequency from the adjustable frequency drive in Hz.
[1614]	Motor Current	Phase current of the motor measured as effective value.
[1615]	Frequency [%]	Motor frequency, i.e., the output frequency from the adjustable frequency drive as a percentage.
[1616]	Torque [Nm]	Present motor load as a percentage of the rated motor torque.
[1617]	Speed [RPM]	Speed in RPM (revolutions per minute), i.e., the motor shaft speed in closed-loop based on the entered motor nameplate data, the output frequency and the load on the adjustable frequency drive.
[1618]	Motor Thermal	Thermal load on the motor, calculated by the ETR function. See also parameter group 1-9* Motor Temperature.
[1622]	Torque [%]	Shows the actual torque produced as a percentage.
[1630]	DC Link Voltage	Intermediate circuit voltage in the adjustable frequency drive.
[1632]	Brake Energy/sec.	Present braking energy transferred to an external brake resistor. Stated as an instantaneous value.
[1633]	Brake Energy/2 min	Braking energy transferred to an external brake resistor. The mean power is calculated continuously for the latest 120 seconds.

[1634]	Heatsink Temp.		Present heatsink temperature of the adjustable frequency drive. The cut-out limit is 203° F ± 9° F [95° C ± 5° C]; cutting back in occurs at 158° F ± 9° F [70° C ± 5° C].
[1635]	Thermal Drive Load		Percentage load of the inverters
[1636]	Inv. Nom. Current		Nominal current of the adjustable frequency drive.
[1637]	Inv. Max. Current		Maximum current of the adjustable frequency drive.
[1638]	SL Control State		State of the event executed by the control.
[1639]	Control Card Temp.		Temperature of the control card.
[1650]	External Reference		Sum of the external reference as a percentage, i.e., the sum of analog/pulse/bus.
[1652]	Feedback [Unit]		Signal value in units from the programmed digital input(s).
[1653]	DigiPot Reference		View the contribution of the digital potentiometer to the actual reference feedback.
[1654]	Feedback 1 [Unit]		View the value of Feedback 1. See also par. 20-0*.
[1655]	Feedback 2 [Unit]		View the value of Feedback 2. See also par. 20-0*.
[1656]	Feedback 3 [Unit]		View the value of Feedback 3. See also par. 20-0*.
[1660]	Digital Input		Displays the status of the 6 digital input terminals (18, 19, 27, 29, 32 and 33). Input 18 corresponds to the bit at the far left. Signal low = 0; Signal high = 1
[1661]	Terminal 53	Switch Setting	Setting of input terminal 53. Current = 0; Voltage = 1.
[1662]	Analog Input 53		Actual value at input 53 either as a reference or protection value.
[1663]	Terminal 54	Switch Setting	Setting of input terminal 54. Current = 0; Voltage = 1.
[1664]	Analog Input 54		Actual value at input 54 either as reference or protection value.
[1665]	Analog Output [mA]	42	Actual value at output 42 in mA. Use par. 6-50 to select the variable to be represented by output 42.
[1666]	Digital Output [bin]		Binary value of all digital outputs.
[1667]	Freq. Input #29 [Hz]		Actual value of the frequency applied at terminal 29 as a pulse input.
[1668]	Freq. Input #33 [Hz]		Actual value of the frequency applied at terminal 33 as a pulse input.
[1669]	Pulse Output [Hz]	#27	Actual value of pulses applied to terminal 27 in digital output mode.
[1670]	Pulse Output [Hz]	#29	Actual value of pulses applied to terminal 29 in digital output mode.
[1671]	Relay Output [bin]		View the setting of all relays.

[1672]	Counter A	View the present value of Counter A.
[1673]	Counter B	View the present value of Counter B.
[1675]	Analog input X30/11	Actual value of the signal on input X30/11 (General Purpose I/O Card. Option)
[1676]	Analog input X30/12	Actual value of the signal on input X30/12 (General Purpose I/O Card. Optional)
[1677]	Analog output X30/8 [mA]	Actual value at output X30/8 (General Purpose I/O Card. Optional) Use Par. 6-60 to select the variable to be shown.
[1680]	Ser. Com. Bus CTW 1	Control word (CTW) received from the bus master.
[1682]	Ser. com. bus REF 1	Main reference value sent with control word via the serial communications network, such as from the BMS, PLC or another master controller, for example.
[1684]	Comm. Option STW	Extended serial communication bus option status word.
[1685]	FC Port CTW 1	Control word (CTW) received from the bus master.
[1686]	FC Port REF 1	Status word (STW) sent to the bus master.
[1690]	Alarm Word	One or more alarms in a Hex code (used for serial communications).
[1691]	Alarm Word 2	One or more alarms in a Hex code (used for serial communications).
[1692]	Warning Word	One or more warnings in a Hex code (used for serial communications).
[1693]	Warning Word 2	One or more warnings in a Hex code (used for serial communications).
[1694]	Ext. Status Word	One or more status conditions in a Hex code (used for serial communications).
[1695]	Ext. Status Word 2	One or more status conditions in a Hex code (used for serial communications).
[1696]	Maintenance Word	The bits reflect the status for the programmed preventive maintenance events in parameter group 23-1*.
[1830]	Analog Input X42/1	Shows the value of the signal applied to terminal X42/1 on the analog I/O card.
[1831]	Analog Input X42/3	Shows the value of the signal applied to terminal X42/3 on the analog I/O card.
[1832]	Analog Input X42/5	Shows the value of the signal applied to terminal X42/5 on the analog I/O card.
[1833]	Analog Out X42/7 [V]	Shows the value of the signal applied to terminal X42/7 on the analog I/O card.

[1834]	Analog Out X42/9 [V]	Shows the value of the signal applied to terminal X42/9 on the analog I/O card.
[1835]	Analog Out X42/11 [V]	Shows the value of the signal applied to terminal X42/11 on the analog I/O card.
[2117]	Ext. 1 Reference [Unit]	The value of the reference for extended closed-loop controller 1.
[2118]	Ext. 1 Feedback [Unit]	The value of the feedback signal for extended closed-loop controller 1.
[2119]	Ext. 1 Output [%]	The value of the output from extended closed-loop controller 1.
[2137]	Ext. 2 Reference [Unit]	The value of the reference for extended closed-loop controller 2.
[2138]	Ext. 2 Feedback [Unit]	The value of the feedback signal for extended closed-loop controller 2.
[2139]	Ext. 2 Output [%]	The value of the output from extended closed-loop controller 2.
[2157]	Ext. 3 Reference [Unit]	The value of the reference for extended closed-loop controller 3.
[2158]	Ext. 3 Feedback [Unit]	The value of the feedback signal for extended closed-loop controller 3.
[2159]	Ext. Output [%]	The value of the output from extended closed-loop controller 3.
[2230]	No-Flow Power	The calculated no-flow power for the actual operating speed.
[2580]	Cascade Status	Status for the operation of the cascade controller.
[2581]	Pump Status	Status for the operation of each individual pump controlled by the cascade controller.



NOTE

Please consult the **VLT® AQUA Drive Programming Guide, MG.20.OX.YY** for detailed information.

0-21 Display Line 1.2 Small

Option:

Function:

Select a variable for display in line 1, middle position.

[1662] *Analog input 53

The options are the same as those listed for par. 0-20 *Display Line 1.1 Small*.

0-22 Display Line 1.3 Small

Option:

Function:

Select a variable for display in line 1, right position.

[1614] * Motor Current The options are the same as those listed for par. 0-20 *Display Line 1.1 Small*.

0-23 Display Line 2 Large

Option:

Function:

Select a variable for display in line 2. The options are the same as those listed for par. 0-20 *Display Line 1.1 Small*.

[1615] * Frequency

0-24 Display Line 3 Large

Option:

Function:

[1652] * Feedback [Unit]

Select a variable for display in line 2. The options are the same as those listed for par. 0-20 *Display Line 1.1 Small*.

0-37 Display Text 1

Option:

Function:

In this parameter, it is possible to write an individual text string for display in the LCP or to be read via serial communication. If to be displayed permanently select Display Text 1 in par. 0-20, 0-21, 0-22, 0-23 or 0-24, *Display Line XXX*. Use the ▲ or ▼ buttons on the LCP to change a character. Use the ◀ and ▶ buttons to move the cursor. When a character is highlighted by the cursor, it can be changed. Use the ▲ or ▼ buttons on the LCP to change a character. A character can be inserted by placing the cursor between two characters and pressing ▲ or ▼.

0-38 Display Text 2

Option:

Function:

In this parameter, it is possible to write an individual text string for display in the LCP or to be read via serial communication. If to be displayed permanently, select Display Text 2 in par. 0-20, 0-21, 0-22, 0-23 or 0-24, *Display Line XXX*. Use the ▲ or ▼ buttons on the LCP to change a character. Use the ◀ and ▶ buttons to move the cursor. When a character is highlighted by the cursor, this character can be changed. A character can be inserted by placing the cursor between two characters and pressing ▲ or ▼.

0-39 Display Text 3

Option:

Function:

In this parameter, it is possible to write an individual text string for display in the LCP or to be read via serial communication. If to be displayed permanently, select Display Text 3 in par. 0-20, 0-21, 0-22, 0-23 or 0-24, *Display Line XXX*. Use the ▲ or ▼ buttons on the LCP to change a character. Use the ◀ and ▶ buttons to move the cursor. When a character is highlighted by the cursor, this character can be changed. A character can be inserted by placing the cursor between two characters and pressing ▲ or ▼.

0-70 Set Date and Time

Range:

2000-01 [2000-01-01 00:00]
-01
00:00 –
2099-12
-01
23:59 *

Function:

Sets the date and time of the internal clock. The format to be used is set in par. 0-71 and 0-72.



NOTE

This parameter does not display the actual time. This can be read in par. 0-89. The clock will not begin counting until a setting different from default has been made.

0-71 Date Format

Option:

[0] * YYYY-MM-DD
[1] DD-MM-YYYY
[2] MM/DD/YYYY

Function:

Sets the date format to be used in the LCP.
Sets the date format to be used in the LCP.
Sets the date format to be used in the LCP.

0-72 Time Format

Option:

[0] * 24 H
[1] 12 H

Function:

Sets the time format to be used in the LCP.

0-74 DST/Summertime

Option:

[0] * OFF
[2] Manual

Function:

Choose how Daylight Saving Time/Summertime should be handled. For manual DST/Summertime, enter the start date and end date in par. 0-76 and 0-77.

0-76 DST/Summertime Start

Range: 2000-01 [2000-01-01 00:00 – Sets the date and time when Summertime/DST starts. The date
-01 2099-12-31 23:59] is programmed in the format selected in par. 0-71.
00:00*

0-77 DST/Summertime End

Range: 2000-01 [2000-01-01 00:00 – Sets the date and time when Summertime/DST ends. The date
-01 2099-12-31 23:59] is programmed in the format selected in par. 0-71.
00:00*

1-00 Configuration Mode

Option:	Function:
[0] * Open-loop	Motor speed is determined by applying a speed reference or by setting desired speed when in hand mode. Open-loop is also used if the adjustable frequency drive is part of a closed-loop control system based on an external PID controller providing a speed reference signal as output.
[3] Closed-loop	Motor speed will be determined by a reference from the built-in PID controller varying the motor speed as part of a closed-loop control process (e.g., constant pressure or flow). The PID controller must be configured in par. 20-**, Drive Closed-loop or via the function set-ups accessed by pressing the [Quick Menu] button.

This parameter cannot be changed while the motor is running.



NOTE

When set for closed-loop, the commands reversing and start reversing will not reverse the direction of the motor.

3-02 Minimum Reference

Range: 0.000 [-100000.000 – par. Enter the Minimum Reference. The Minimum Reference is the
Unit* 3-03] lowest value obtainable by adding all references together.

3-03 Maximum Reference

Option: [0.000 Par. 3-02 - Enter the maximum reference. The maximum reference is the
Unit] * 100000.000 highest value obtainable by adding all references together.

3-10 Preset Reference

Array [8]

0.00%* [-100.00 - 100.00 %] Enter up to eight different preset references (0-7) in this parameter using array programming. The preset reference is stated as a percentage of the value Ref_{MAX} (par. 3-03 *Maximum Reference*) or as a percentage of the other external references. If a Ref_{MIN} different from 0 (Par. 3-02 *Minimum Reference*) is programmed, the preset reference is calculated as a percentage of the full reference range, i.e., on the basis of the difference between Ref_{MAX} and Ref_{MIN}. Afterwards, the value is added to Ref_{MIN}. When using preset references, select Preset ref. bit 0 / 1 / 2 [16], [17] or [18] for the corresponding digital inputs in parameter group 5.1* Digital Inputs.

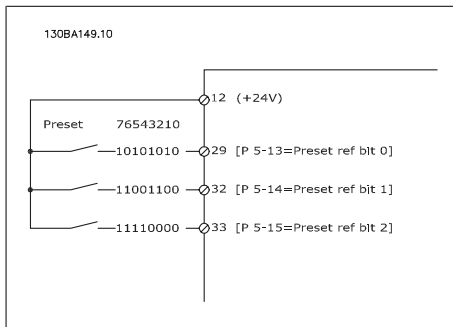

5-13 Terminal 29 Digital Input

Option:	Function:
[0] * No Operation	Same options and functions as par. 5-1* <i>Digital Inputs</i> .

5-14 Terminal 32 Digital Input

Option:	Function:
[0] * No Operation	Same options and functions as par. 5-1* <i>Digital Inputs</i> , except for <i>Pulse input</i> .

5-15 Terminal 33 Digital Input

Option:	Function:
[0] * No Operation	Same options and functions as par. 5-1* <i>Digital Inputs</i> .

5-40 Function Relay

Array [8]	(Relay 1 [0], Relay 2 [1], Relay 7 [6], Relay 8 [7], Relay 9 [8])
-----------	---

Select options to define the function of the relays.

The selection of each mechanical relay is realized in an array parameter.

[0]	No Operation
[1]	Control Ready
[2]	Drive Ready
[3]	Drive Ready/Remote
[4]	Stand-by/No Warning
[5] *	Running
[6]	Running/No Warning
[8]	Run on Ref./No Warning
[9]	Alarm
[10]	Alarm or Warning
[11]	At Torque Limit
[12]	Out of Current Range
[13]	Below Current, low
[14]	Above Current, high
[15]	Out of Speed Range
[16]	Below Speed, low
[17]	Above Speed, high
[18]	Out of Feedb. Range
[19]	Below Feedback, low
[20]	Above Feedback, high
[21]	Thermal Warning
[25]	Reverse
[26]	Bus OK
[27]	Torque Limit & Stop
[28]	Brake, No Warning
[29]	Brake Ready, No Fault
[30]	Brake Fault (IGBT)
[35]	External Interlock
[36]	Control Word Bit 11
[37]	Control Word Bit 12
[40]	Out of Ref. Range
[41]	Below Reference, low
[42]	Above Ref. high
[45]	Bus ctrl
[46]	Bus ctrl, 1 if timeout
[47]	Bus ctrl, 0 if timeout

[60]	Comparator 0
[61]	Comparator 1
[62]	Comparator 2
[63]	Comparator 3
[64]	Comparator 4
[65]	Comparator 5
[70]	Logic Rule 0
[71]	Logic Rule 1
[72]	Logic Rule 2
[73]	Logic Rule 3
[74]	Logic Rule 4
[75]	Logic Rule 5
[80]	SL Digital Output A
[81]	SL Digital Output B
[82]	SL Digital Output C
[83]	SL Digital Output D
[84]	SL Digital Output E
[85]	SL Digital Output F
[160]	No Alarm
[161]	Running Reverse
[165]	Local Ref. Active
[166]	Remote Ref. Active
[167]	Start Cmd. Active
[168]	Drive in Hand Mode
[169]	Drive in Auto Mode
[180]	Clock Fault
[181]	Prev. Maintenance
[190]	No-Flow
[191]	Dry Pump
[192]	End of Curve
[193]	Sleep Mode
[194]	Broken Belt
[195]	Bypass Valve Control
[196]	Pipe Filling
[211]	Cascade Pump1
[212]	Cascade Pump2
[213]	Cascade Pump3
[223]	Alarm, Trip-locked
[224]	Bypass Mode Active

6-00 Live Zero Timeout Time

Range:

10 s* [1 - 99 s]

Function:

Enter the Live Zero Timeout time period. Live Zero Timeout Time is active for analog inputs, (i.e., terminal 53 or terminal 54), allocated to current and used as reference or feedback sources. If the reference signal value associated with the selected current input falls below 50% of the value set in par. 6-10, par. 6-12, par. 6-20 or par. 6-22 for a period of time longer than that set in par. 6-00, the function selected in par. 6-01 will be activated.

6-01 Live Zero Timeout Function

Option:
Function:

Select the timeout function. The function set in par. 6-01 will be activated if the input signal on terminal 53 or 54 is below 50% of the value in par. 6-10, par. 6-12, par. 6-20 or par. 6-22 for a time period defined in par. 6-00. If several timeouts occur simultaneously, the adjustable frequency drive prioritizes the timeout functions as follows:

1. Par. 6-01 *Live Zero Timeout Function*
2. Par. 8-04 *Control Word Timeout Function*

The output frequency of the adjustable frequency drive can be:

- [1] frozen at the present value
- [2] overruled to stop
- [3] overruled to jog speed
- [4] overruled to max. speed
- [5] overruled to stop with subsequent trip

If you select set-up 1-4, par. 0-10, *Active Set-up*, must be set to *Multi Set-up*, [9].

This parameter cannot be adjusted while the motor is running.

[0] *	Off
[1]	Freeze output
[2]	Stop
[3]	Jogging
[4]	Max. speed
[5]	Stop and trip

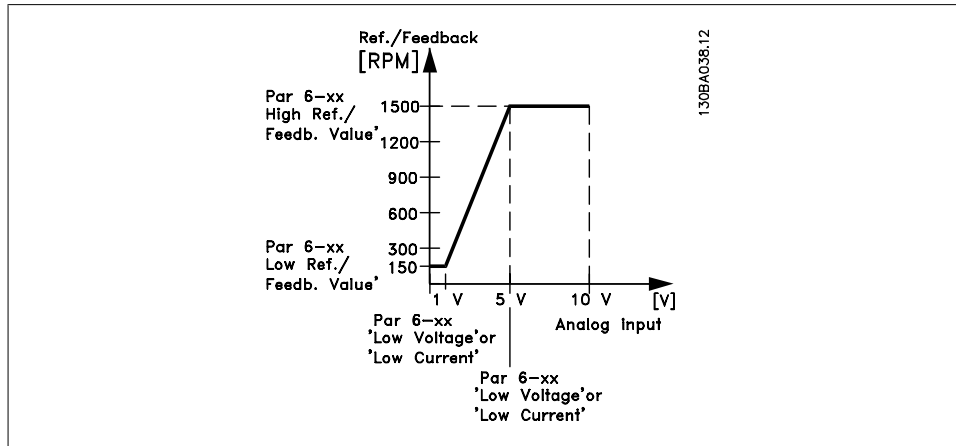

6-10 Terminal 53 Low Voltage

Range: 0.07V* [0.00 - par. 6-11] **Function:** Enter the low voltage value. This analog input scaling value should correspond to the low reference/feedback value set in par. 6-14.

6-11 Terminal 53 High Voltage

Range: 10.0 V* [Par. 6-10 to 10.0 V] **Function:** Enter the high voltage value. This analog input scaling value should correspond to the high reference/feedback value set in par. 6-15.

6-14 Terminal 53 Low Ref./Feedb. Value

Range: 0.000 [-1000000.000 to par. Unit* 6-15] **Function:** Enter the analog input scaling value that corresponds to the low voltage/low current set in par. 6-10 and 6-12.

6-15 Terminal 53 High Ref./Feedb. Value

Range: 100.000 [Par. 6-14 to Unit* 1,000,000.000] **Function:** Enter the analog input scaling value that corresponds to the high voltage/high current value set in par. 6-11/6-13.

6-20 Terminal 54 Low Voltage

Range: 0.07V* [0.00 - par. 6-21] **Function:** Enter the low voltage value. This analog input scaling value should correspond to the low reference/feedback value set in par. 6-24.

6-21 Terminal 54 High Voltage

Range:	Function:
10.0 V* [Par. 6-20 to 10.0 V]	Enter the high voltage value. This analog input scaling value should correspond to the high reference/feedback value set in par. 6-25.

6-24 Terminal 54 Low Ref./Feedb. Value

Range:	Function:
0.000 [-1,000,000.000 to 1000.000] Unit* par. 6-25]	Enter the analog input scaling value that corresponds to the low voltage/low current value set in par. 6-20/6-22.

6-25 Terminal 54 high ref./feedb. value

Range:	Function:
100.000 [Par. 6-24 to 1,000,000.000] Unit*	Enter the analog input scaling value that corresponds to the high voltage/high current value set in par. 6-21/6-23.

6-50 Terminal 42 Output

Option:	Function:
----------------	------------------

[0]	No operation
[100] *	Output frequency
[101]	Reference
[102]	Feedback
[103]	Motor current
[104]	Torque rel to lim
[105]	Torque rel to rated
[106]	Power
[107]	Speed
[108]	Torque
[113]	Ext. closed-loop 1
[114]	Ext. closed-loop 2
[115]	Ext. closed-loop 3
[130]	Output freq. 4-20 mA
[131]	Reference 4-20 mA
[132]	Feedback 4-20 mA
[133]	Motor cur. 4-20 mA
[134]	Torque % lim. 4-20 mA
[135]	Torque % nom 4-20 mA
[136]	Power 4-20 mA
[137]	Speed 4-20 mA

- [138] Torque 4-20 mA
- [139] Bus ctrl. 0-20 mA
- [140] Bus ctrl. 4-20 mA
- [141] Bus ctrl. 0-20 mA, timeout
- [142] Bus ctrl. 4-20 mA, timeout
- [143] Ext. Closed-loop 1, 4-20 mA
- [144] Ext. Closed-loop 2, 4-20 mA
- [145] Ext. Closed-loop 3, Select the function of terminal 42 as an analog current output. 4-20 mA

6-51 Terminal 42 Output Min Scale

Range:

0%* [0 – 200%]

Function:

Scale the minimum output of the selected analog signal at terminal 42, as a percentage of the maximum signal value. For example, if 0 mA (or 0 Hz) is desired at 25% of the maximum output value, program it to 25%. Scaling values up to 100% can never be higher than the corresponding setting in par. 6-52.

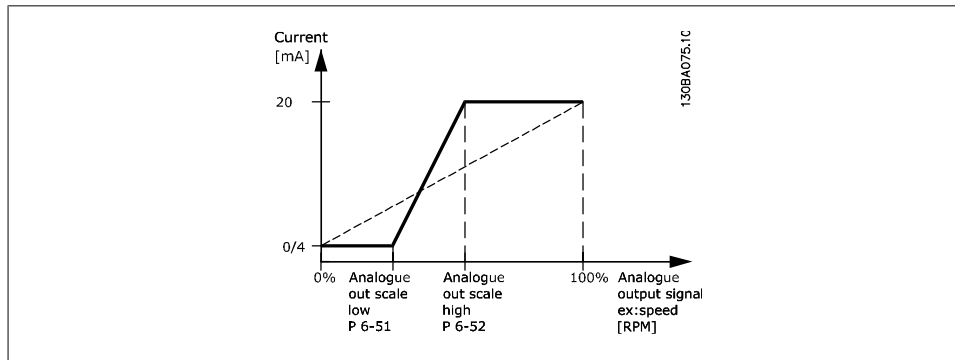

6-52 Terminal 42 Output Max Scale

Range:

100%* [0.00 – 200%]

Function:

Scale the maximum output of the selected analog signal at terminal 42. Set the value to the maximum value of the current signal output. Scale the output to give a current lower than 20 mA at full scale; or 20 mA at an output below 100% of the maximum signal value. If 20 mA is the desired output current at a value between 0 - 100% of the full-scale output, program the percentage value in the parameter, i.e., 50% = 20 mA. If a current between 4 and 20 mA is desired at maximum output (100%), calculate the percentage value as follows:

$$20 \text{ mA} / \text{desired maximum current} \times 100 \%$$

i.e. 10mA: $\frac{20 \text{ mA}}{10 \text{ mA}} \times 100 \% = 200 \%$

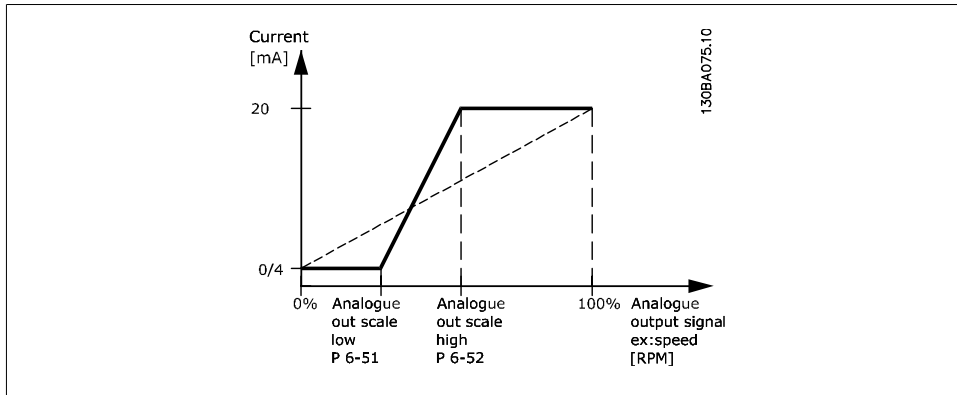

20-12 Reference/Feedback Unit

Option:	Function:
[0]	None
[1] *	%
[5]	PPM
[10]	1/min
[11]	RPM
[12]	Pulse/s
[20]	l/s
[21]	l/min
[22]	l/h
[23]	m ³ /s
[24]	m ³ /min
[25]	m ³ /h
[30]	kg/s
[31]	kg/min
[32]	kg/h
[33]	t/min
[34]	t/h
[40]	m/s
[41]	m/min
[45]	m
[60]	°C
[70]	mbar
[71]	bar
[72]	Pa
[73]	kPa

[74]	m WG
[75]	mm Hg
[80]	kW
[120]	GPM
[121]	gal/s
[122]	gal/min
[123]	gal/h
[124]	CFM
[125]	ft ³ /s
[126]	ft ³ /min
[127]	ft ³ /h
[130]	lb/s
[131]	lb/min
[132]	lb/h
[140]	ft/s
[141]	ft/min
[145]	ft
[160]	°F
[170]	psi
[171]	lb/in ²
[172]	in WG
[173]	ft WG
[174]	in Hg
[180]	HP

This parameter determines the unit that is used for the setpoint reference and feedback that the PID controller will use for controlling the output frequency of the adjustable frequency drive.

20-21 Setpoint 1

Range:

0.000* [Ref_{MIN} par.3-02 - Ref_{MAX} par. 3-03 UNIT (from par. 20-12)]

Function:

Setpoint 1 is used in closed-loop mode to enter a setpoint reference that is used by the adjustable frequency drive's PID controller. See the description of *Feedback Function*, par. 20-20.



NOTE

Setpoint reference entered here is added to any other references that are enabled (see par. group 3-1*).

20-81 PID Normal/Inverse Control

Option:

[0] * Normal

[1] Inverse

Function:

Normal [0] causes the adjustable frequency drive's output frequency to decrease when the feedback is greater than the setpoint reference. This is common for pressure-controlled supply fan and pump applications.

Inverse [1] causes the adjustable frequency drive's output frequency to increase when the feedback is greater than the setpoint reference.

20-82 PID Start Speed [RPM]

Range:

0* [0 - 6,000 RPM]

Function:

When the adjustable frequency drive is first started, it initially ramps up to this output speed in open-loop mode, following the active ramp-up time. When the output speed programmed here is reached, the adjustable frequency drive will automatically switch to closed-loop mode and the PID controller will begin to function. This is useful in applications in which the driven load must first quickly accelerate to a minimum speed when it is started.

NOTE

This parameter will only be visible if par. 0-02 is set to [0], RPM.

20-93 PID Proportional Gain

Range:

0.50* [0.00 = Off - 10.00]

Function:

This parameter adjusts the output of the adjustable frequency drive's PID controller based on the error between the feedback and the setpoint reference. The quick PID controller response is obtained when this value is large. However, if a value that is too large is used, the adjustable frequency drive's output frequency may become unstable.

20-94 PID Integral Time

Range:

20.00 s* [0.01 - 10,000.00 = Off s]

Function:

Over time, the integrator adds (integrates) the error between the feedback and the setpoint reference. This is required to ensure that the error approaches zero. Quick adjustable frequency drive speed adjustment is obtained when this value is small.

However, if a value that is too small is used, the adjustable frequency drive's output frequency may become unstable.

4.1.4. Main Menu Mode

Both the GLCP and NLCP provide access to the Main Menu mode. Select Main Menu mode by pressing the [Main Menu] key. Illustration 6.2 shows the resulting readout, which appears on the display of the GLCP.

Lines 2 through 5 on the display show a list of parameter groups which can be chosen by toggling the up and down buttons.

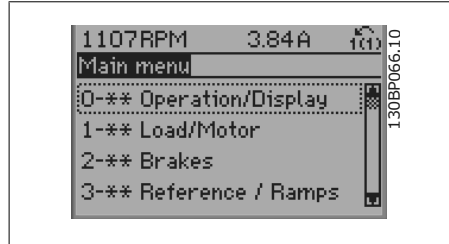

4.9: Display example.

Each parameter has a name and number that remain the same regardless of the programming mode. In main menu mode, the parameters are divided into groups. The first digit of the parameter number (from the left) indicates the parameter group number.

All parameters can be changed in the main menu. The configuration of the unit (par. 1-00) will determine other parameters available for programming. For example, selecting Closed-loop enables additional parameters related to closed-loop operation. Option cards added to the unit enable additional parameters associated with the option device.

4.1.5. Parameter Selection

In main menu mode, the parameters are divided into groups. Select a parameter group using the navigation keys.

The following parameter groups are accessible:

Group no.	Parameter group:
0	Operation/Display
1	Load/Motor
2	Brakes
3	References/Ramps
4	Limits/Warnings
5	Digital In/Out
6	Analog In/Out
8	Comm. and Options
9	Profibus
10	CAN ser. com. bus
11	LonWorks
13	Smart Logic
14	Special Functions
15	Drive Information
16	Data Readouts
18	Data Readouts 2
20	Drive Closed-loop
21	Ext. Closed-loop
22	Application Functions
23	Time-based Functions
24	Fire Mode
25	Cascade Controller
26	Analog I/O Option MCB 109

4.3: Parameter groups.

After selecting a parameter group, choose a parameter using the navigation keys. The middle section on the GLCP display shows the parameter number and name, as well as the selected parameter value.

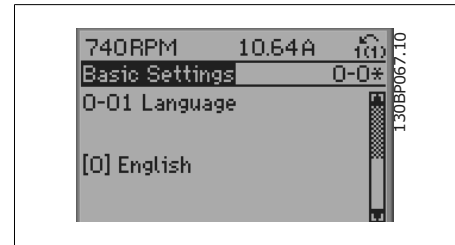

4.10: Display example.

4.1.6. Changing Data

1. Press the [Quick Menu] or [Main Menu] key.
2. Use the [▲] and [▼] keys to find the parameter group to edit.
3. Use the [▲] and [▼] keys to find the parameter to edit.
4. Press the [OK] key.
5. Use the [▲] and [▼] keys to select the correct parameter setting. Or, to move to digits within a number, use the keys. The cursor indicates the selected digit to be changed. The [▲] key increases the value, the [▼] key decreases the value.
6. Press the [Cancel] key to disregard the change, or press the [OK] key to accept the change and enter the new setting.

4.1.7. Changing a Text Value

If the selected parameter is a text value, change the text value using the up/down navigation keys.

The up key increases the value, and the down key decreases the value. Place the cursor on the value to be saved and press [OK].

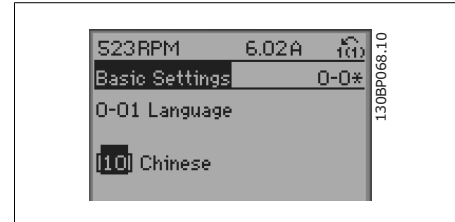

4.11: Display example.

4.1.8. Changing a Group of Numeric Data Values

If the chosen parameter represents a numeric data value, change the chosen data value using the <> navigation keys as well as the up/down navigation keys. Use the <> navigation keys to move the cursor horizontally.

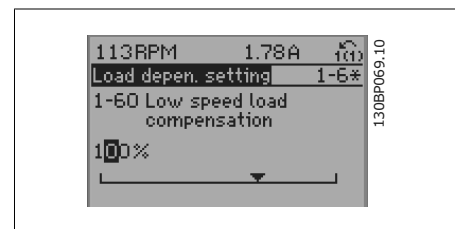

4.12: Display example.

Use the up/down navigation keys to change the data value. The up key increases the data value, and the down key reduces the data value. Place the cursor on the value to be saved and press [OK].

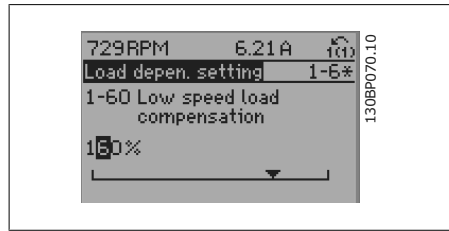

4.13: Display example.

4

4.1.9. Changing Data Value, Step-by-Step

Certain parameters can be changed step-by-step or by an infinite number of variables. This applies to *Motor Power* (par. 1-20), *Motor Voltage* (par. 1-22) and *Motor Frequency* (par. 1-23). The parameters are changed both as a group of numeric data values and as numeric data values using an infinite number of variables.

4.1.10. Readout and Programming of Indexed Parameters

Parameters are indexed when placed in a rolling stack.

Par. 15-30 to 15-32 contain a fault log that can be read out. Choose a parameter, press [OK], and use the up/down navigation keys to scroll through the value log.

Use par. 3-10 as another example:

Choose the parameter, press [OK], and use the up/down navigation keys to scroll through the indexed values. To change the parameter value, select the indexed value and press [OK]. Change the value by using the up/down keys. Press [OK] to accept the new setting. Press [Cancel] to abort. Press [Back] to leave the parameter.

20-81 PID Normal/Inverse Control

Option:	Function:
[0] * Normal	
[1] Inverse	<p><i>Normal</i> [0] causes the adjustable frequency drive's output frequency to decrease when the feedback is greater than the setpoint reference. This is common for pressure-controlled supply fan and pump applications.</p> <p><i>Inverse</i> [1] causes the adjustable frequency drive's output frequency to increase when the feedback is greater than the setpoint reference. This is common for temperature-controlled cooling applications, such as cooling towers.</p>

4.1.11. Initialization to Default Settings

Initialize the adjustable frequency drive using default settings in two ways:

Recommended initialization (via par. 14-22)

1. Select par. 14-22
2. Press [OK]
3. Select "Initialization"
4. Press [OK]
5. Cut off the line power supply and wait until the display turns off.
6. Reconnect the line power supply - the adjustable frequency drive is now reset.
7. Change par. 14-22 back to *Normal Operation*.



NOTE

Keeps parameters selected in *Personal Menu* with default factory setting.

Par. 14-22 initializes everything except:

14-50	<i>RFI 1</i>
8-30	<i>Protocol</i>
8-31	<i>Address</i>
8-32	<i>Baud Rate</i>
8-35	<i>Minimum Response Delay</i>
8-36	<i>Max Response Delay</i>
8-37	<i>Max Inter-char Delay</i>
15-00 to 15-05	Operating data
15-20 to 15-22	Historical log
15-30 to 15-32	Fault log

Manual initialization

1. Disconnect from the power supply and wait until the display turns off.
- 2a. Press [Status] - [Main Menu] - [OK] at the same time the LCP 102, Graphical Display is powering up.
- 2b. Press [Menu] while the LCP 101, Numerical Display is powering up.
3. Release the keys after 5 s.
4. The adjustable frequency drive is now programmed according to default settings.

This procedure initializes all except:

15-00	<i>Operating Hours</i>
15-03	<i>Power-ups</i>
15-04	<i>Overtmps</i>
15-05	<i>Overvolts</i>



NOTE

When you carry out manual initialization, you also reset serial communication, RFI filter settings (par. 14-50) and fault log settings. Removes parameters selected in *Personal Menu*.



NOTE

After initialization and power cycling, the display will not show any information until after a couple of minutes.

4.2. Parameter Options

4.2.1. Default settings

4

Changes during operation

"TRUE" means that the parameter can be changed while the adjustable frequency drive is in operation and "FALSE" means that the adjustable frequency drive must be stopped before a change can be made.

4-Set-up

'All set-up': the parameter can be set individually in each of the four set-ups, i.e., one single parameter can have four different data values.

'1 set-up': the data value will be the same in all set-ups.

Conversion index

This number refers to a conversion figure used when writing or reading by means of an adjustable frequency drive.

Conv. index	100	67	6	5	4	3	2	1	0	-1	-2	-3	-4	-5	-6
Conv. factor	1	1/60	100000 0	100000	10000	1000	100	10	1	0.1	0.01	0.00 1	0.000 1	0.0000 1	0.000001

Data type	Description	Type
2	Integer 8	Int8
3	Integer 16	Int16
4	Integer 32	Int32
5	Unsigned 8	UInt8
6	Unsigned 16	UInt16
7	Unsigned 32	UInt32
9	Visible String	VisStr
33	Normalized value 2 bytes	N2
35	Bit sequence of 16 Boolean variables	V2
54	Time difference w/o date	TimD

SR = Size related

4.2.2. 0-** Operation/Display

Par. No. #	Parameter description	Default value	4 set-up	Change during operation	Conversion index	Type
0-0* Basic Settings						
0-01	Language	[0] English	1 set-up	TRUE	-	Uint8
0-02	Motor Speed Unit	[0] RPM	2 set-ups	FALSE	-	Uint8
0-03	Regional Settings	[0] International	All set-ups	TRUE	-	Uint8
0-04	Operating State at Power-up	[0] Resume	2 set-ups	FALSE	-	Uint8
0-1* Set-up Operations						
0-10	Active Set-up	[1] Set-up 1	1 set-up	TRUE	-	Uint8
0-11	Programming Set-up	[9] Active Set-up	All set-ups	TRUE	-	Uint8
0-12	This Set-up Linked to	[0] Not linked	All set-ups	FALSE	-	Uint8
0-13	Readout: Linked Set-ups	0 N/A	All set-ups	FALSE	0	Uint16
0-14	Readout: Prog. Set-ups/Channel	0 N/A	All set-ups	TRUE	0	Int32
0-2* LCP Display						
0-20	Display Line 1.1 Small	1601	All set-ups	TRUE	-	Uint16
0-21	Display Line 1.2 Small	1662	All set-ups	TRUE	-	Uint16
0-22	Display Line 1.3 Small	1614	All set-ups	TRUE	-	Uint16
0-23	Display Line 2 Large	1613	All set-ups	TRUE	-	Uint16
0-24	Display Line 3 Large	1652	All set-ups	TRUE	-	Uint16
0-25	My Personal Menu	SR	1 set-up	TRUE	0	Uint16
0-3* LCP Custom Readout						
0-30	Custom Readout Unit	[1] %	All set-ups	TRUE	-	Uint8
0-31	Custom Readout Min Value	SR	All set-ups	TRUE	-2	Int32
0-32	Custom Readout Max Value	100.00 CustomReadoutUnit	All set-ups	TRUE	-2	Int32
0-37	Display Text 1	0 N/A	1 set-up	TRUE	0	VisStr[25]
0-38	Display Text 2	0 N/A	1 set-up	TRUE	0	VisStr[25]
0-39	Display Text 3	0 N/A	1 set-up	TRUE	0	VisStr[25]
0-4* LCP Keypad						
0-40	[Hand on] Key on LCP	[1] Enabled	All set-ups	TRUE	-	Uint8
0-41	[Off] Key on LCP	[1] Enabled	All set-ups	TRUE	-	Uint8
0-42	[Auto on] Key on LCP	[1] Enabled	All set-ups	TRUE	-	Uint8
0-43	[Reset] Key on LCP	[1] Enabled	All set-ups	TRUE	-	Uint8
0-44	[Off/Reset] Key on LCP	[1] Enabled	All set-ups	TRUE	-	Uint8
0-45	[Drive Bypass] Key on LCP	[1] Enabled	All set-ups	TRUE	-	Uint8
0-5* Copy/Save						
0-50	LCP Copy	[0] No copy	All set-ups	FALSE	-	Uint8
0-51	Set-up Copy	[0] No copy	All set-ups	FALSE	-	Uint8
0-6* Password						
0-60	Main Menu Password	100 N/A	1 set-up	TRUE	0	Uint16
0-61	Access to Main Menu w/o Password	[0] Full access	1 set-up	TRUE	-	Uint8
0-65	Personal Menu Password	200 N/A	1 set-up	TRUE	0	Uint16
0-66	Access to Personal Menu w/o Password	[0] Full access	1 set-up	TRUE	-	Uint8

Par. No. #	Parameter description	Default value	4 set-up	Change during operation	Conversion index	Type
0-7* Clock Settings						
0-70	Set Date and Time	SR	1 set-up	TRUE	0	TimeOfDay
0-71	Date Format	[0] YYYY-MM-DD	1 set-up	TRUE	-	Uint8
0-72	Time Format	[0] 24h	1 set-up	TRUE	-	Uint8
0-74	DST/Summertime	[0] Off	1 set-up	TRUE	-	Uint8
0-76	DST/Summertime Start	SR	1 set-up	TRUE	0	TimeOfDay
0-77	DST/Summertime End	SR	1 set-up	TRUE	0	TimeOfDay
0-79	Clock Fault	null	1 set-up	TRUE	-	Uint8
0-81	Working Days	null	1 set-up	TRUE	-	Uint8
0-82	Additional Working Days	SR	1 set-up	TRUE	0	TimeOfDay
0-83	Additional Non-Working Days	SR	1 set-up	TRUE	0	TimeOfDay
0-89	Date and Time Readout	0 N/A	All set-ups	TRUE	0	VisStr[25]

4.2.3. 1-**-** Load/Motor

Par. No. #	Parameter description	Default value	4 set-up	Change during operation	Conversion index	Type
1-0* General Settings						
1-00	Configuration Mode	null	All set-ups	TRUE	-	Uint8
1-03	Torque Characteristics	[3] Auto Energy Optim. VT	All set-ups	TRUE	-	Uint8
1-2* Motor Data						
1-20	Motor Power [kW]	SR	All set-ups	FALSE	1	Uint32
1-21	Motor Power [HP]	SR	All set-ups	FALSE	-2	Uint32
1-22	Motor Voltage	SR	All set-ups	FALSE	0	Uint16
1-23	Motor Frequency	SR	All set-ups	FALSE	0	Uint16
1-24	Motor Current	SR	All set-ups	FALSE	-2	Uint32
1-25	Motor Nominal Speed	SR	All set-ups	FALSE	67	Uint16
1-28	Motor Rotation Check	[0] Off	All set-ups	FALSE	-	Uint8
1-29	Automatic Motor Adaptation (AMA)	[0] Off	All set-ups	FALSE	-	Uint8
1-3* Adv. Motor Data						
1-30	Stator Resistance (Rs)	SR	All set-ups	FALSE	-4	Uint32
1-31	Rotor Resistance (Rr)	SR	All set-ups	FALSE	-4	Uint32
1-35	Main Reactance (Xh)	SR	All set-ups	FALSE	-4	Uint32
1-36	Iron Loss Resistance (Rfe)	SR	All set-ups	FALSE	-3	Uint32
1-39	Motor Poles	SR	All set-ups	FALSE	0	Uint8
1-5* Load Indep. Setting						
1-50	Motor Magnetization at Zero Speed	100 %	All set-ups	TRUE	0	Uint16
1-51	Min Speed Normal Magnetizing [RPM]	SR	All set-ups	TRUE	67	Uint16
1-52	Min Speed Normal Magnetizing [Hz]	SR	All set-ups	TRUE	-1	Uint16
1-6* Load Depen. Setting						
1-60	Low Speed Load Compensation	100 %	All set-ups	TRUE	0	Int16
1-61	High Speed Load Compensation	100 %	All set-ups	TRUE	0	Int16
1-62	Slip Compensation	0 %	All set-ups	TRUE	0	Int16
1-63	Slip Compensation Time Constant	0.10 s	All set-ups	TRUE	-2	Uint16
1-64	Resonance Damping	100 %	All set-ups	TRUE	0	Uint16
1-65	Resonance Damping Time Constant	5 ms	All set-ups	TRUE	-3	Uint8
1-7* Start Adjustments						
1-71	Start Delay	0.0 s	All set-ups	TRUE	-1	Uint16
1-73	Flying Start	[0] Disabled	All set-ups	FALSE	-	Uint8
1-8* Stop Adjustments						
1-80	Function at Stop	[0] Coast	All set-ups	TRUE	-	Uint8
1-81	Min Speed for Function at Stop [RPM]	SR	All set-ups	TRUE	67	Uint16
1-82	Min. Speed for Function at Stop [Hz]	SR	All set-ups	TRUE	-1	Uint16
1-9* Motor Temperature						
1-90	Motor Thermal Protection	[4] ETR trip 1	All set-ups	TRUE	-	Uint8
1-91	Motor External Fan	[0] No	All set-ups	TRUE	-	Uint16
1-93	Thermistor Source	[0] None	All set-ups	TRUE	-	Uint8

4.2.4. 2-** Brakes

Par. No. #	Parameter description	Default value	4 set-up	Change during operation	Conversion index	Type
2-0* DC Brake						
2-00	DC Hold/Preheat Current	50 %	All set-ups	TRUE	0	Uint8
2-01	DC Brake Current	50 %	All set-ups	TRUE	0	Uint16
2-02	DC Braking Time	10.0 s	All set-ups	TRUE	-1	Uint16
2-03	DC Brake Cut-in Speed [RPM]	SR	All set-ups	TRUE	67	Uint16
2-04	DC Brake Cut-in Speed [Hz]	SR	All set-ups	TRUE	-1	Uint16
2-1* Brake Energy Funct.						
2-10	Brake Function	[0] Off	All set-ups	TRUE	-	Uint8
2-11	Brake Resistor (ohm)	SR	All set-ups	TRUE	0	Uint16
2-12	Braking Energy Limit (kW)	SR	All set-ups	TRUE	0	Uint32
2-13	Braking Energy Monitoring	[0] Off	All set-ups	TRUE	-	Uint8
2-15	Brake Check	[0] Off	All set-ups	TRUE	-	Uint8
2-16	AC Brake Max. Current	100.0 %	All set-ups	TRUE	-1	Uint32
2-17	Overvoltage Control	[2] Enabled	All set-ups	TRUE	-	Uint8

4.2.5. 3-* Reference / Ramps

Par. No. #	Parameter description	Default value	4 set-up	Change during operation	Conversion index	Type
3-0* Reference Limits						
3-02	Minimum Reference	SR	All set-ups	TRUE	-3	Int32
3-03	Maximum Reference	SR	All set-ups	TRUE	-3	Int32
3-04	Reference Function	[0] Sum	All set-ups	TRUE	-	UInt8
3-1* References						
3-10	Preset Reference	0.00 %	All set-ups	TRUE	-2	Int16
3-11	Jog Speed [Hz]	SR	All set-ups	TRUE	-1	UInt16
3-13	Reference Site	[0] Linked to Hand / Auto	All set-ups	TRUE	-	UInt8
3-14	Preset Relative Reference	0.00 %	All set-ups	TRUE	-2	Int32
3-15	Reference 1 Source	[1] Analog input 53	All set-ups	TRUE	-	UInt8
3-16	Reference 2 Source	[0] No function	All set-ups	TRUE	-	UInt8
3-17	Reference 3 Source	[0] No function	All set-ups	TRUE	-	UInt8
3-19	Jog Speed [RPM]	SR	All set-ups	TRUE	67	UInt16
3-4* Ramp 1						
3-41	Ramp 1 Ramp-up Time	SR	All set-ups	TRUE	-2	UInt32
3-42	Ramp 1 Ramp-down Time	SR	All set-ups	TRUE	-2	UInt32
3-5* Ramp 2						
3-51	Ramp 2 Ramp-up Time	SR	All set-ups	TRUE	-2	UInt32
3-52	Ramp 2 Ramp-down Time	SR	All set-ups	TRUE	-2	UInt32
3-8* Other Ramps						
3-80	Jog Ramp Time	SR	All set-ups	TRUE	-2	UInt32
3-81	Quick Stop Ramp Time	SR	2 set-ups	TRUE	-2	UInt32
3-84	Initial Ramp Time	0(Off)	All set-ups	TRUE	-	-
3-85	Check Valve Ramp Time	0(Off)	All set-ups	TRUE	-	-
3-86	Check Valve Ramp End Speed [RPM]	Motor Speed Low Limit	All set-ups	TRUE	-	-
3-87	Check Valve Ramp End Speed [Hz]	Motor Speed Low Limit	All set-ups	TRUE	-	-
3-88	Final Ramp Time	0(Off)	All set-ups	TRUE	-	-
3-9* Digital Potentiometer						
3-90	Step Size	0.10 %	All set-ups	TRUE	-2	UInt16
3-91	Ramp Time	1.00 s	All set-ups	TRUE	-2	UInt32
3-92	Power Restore	[0] Off	All set-ups	TRUE	-	UInt8
3-93	Maximum Limit	100 %	All set-ups	TRUE	0	Int16
3-94	Minimum Limit	0 %	All set-ups	TRUE	0	Int16
3-95	Ramp Delay	1.000 N/A	All set-ups	TRUE	-3	TimD

4.2.6. 4-** Limits / Warnings

Par. No. #	Parameter description	Default value	4 set-up	Change during operation	Conversion index	Type
4-1* Motor Limits						
4-10	Motor Speed Direction	[0] Clockwise	All set-ups	FALSE	-	Uint8
4-11	Motor Speed Low Limit [RPM]	SR	All set-ups	TRUE	67	Uint16
4-12	Motor Speed Low Limit [Hz]	SR	All set-ups	TRUE	-1	Uint16
4-13	Motor Speed High Limit [RPM]	SR	All set-ups	TRUE	67	Uint16
4-14	Motor Speed High Limit [Hz]	SR	All set-ups	TRUE	-1	Uint16
4-16	Torque Limit Motor Mode	110.0 %	All set-ups	TRUE	-1	Uint16
4-17	Torque Limit Generator Mode	100.0 %	All set-ups	TRUE	-1	Uint16
4-18	Current Limit	SR	All set-ups	TRUE	-1	Uint32
4-19	Max. Output Frequency	120 Hz	All set-ups	FALSE	-1	Uint16
4-5* Adj. Warnings						
4-50	Warning Current Low	0.00 A	All set-ups	TRUE	-2	Uint32
4-51	Warning Current High	ImaxVLT (P1637)	All set-ups	TRUE	-2	Uint32
4-52	Warning Speed Low	0 RPM	All set-ups	TRUE	67	Uint16
4-53	Warning Speed High	outputSpeedHighLimit (P4113)	All set-ups	TRUE	67	Uint16
4-54	Warning Reference Low	-999999.999 N/A	All set-ups	TRUE	-3	Int32
4-55	Warning Reference High	999999.999 N/A	All set-ups	TRUE	-3	Int32
4-56	Warning Feedback Low	-999999.999 ReferenceFeedbackUnit	All set-ups	TRUE	-3	Int32
4-57	Warning Feedback High	999999.999 ReferenceFeedbackUnit	All set-ups	TRUE	-3	Int32
4-58	Missing Motor Phase Function	[1] On	All set-ups	TRUE	-	Uint8
4-6* Speed Bypass						
4-60	Bypass Speed From [RPM]	SR	All set-ups	TRUE	67	Uint16
4-61	Bypass Speed From [Hz]	SR	All set-ups	TRUE	-1	Uint16
4-62	Bypass Speed To [RPM]	SR	All set-ups	TRUE	67	Uint16
4-63	Bypass Speed To [Hz]	SR	All set-ups	TRUE	-1	Uint16
4-64	Semi-Auto Bypass Set-up	[0] Off	All set-ups	FALSE	-	Uint8

4.2.7. 5-** Digital In/Out

Par. No. #	Parameter description	Default value	4 set-up	Change during operation	Conversion index	Type
5-0* Digital I/O mode						
5-00	Digital I/O Mode	[0] PNP - Active at 24 V	All set-ups	FALSE	-	Uint8
5-01	Terminal 27 Mode	[0] Input	All set-ups	TRUE	-	Uint8
5-02	Terminal 29 Mode	[0] Input	All set-ups	TRUE	-	Uint8
5-1* Digital Inputs						
5-10	Terminal 18 Digital Input	[8] Start	All set-ups	TRUE	-	Uint8
5-11	Terminal 19 Digital Input	[0] No operation	All set-ups	TRUE	-	Uint8
5-12	Terminal 27 Digital Input	[0] No operation	All set-ups	TRUE	-	Uint8
5-13	Terminal 29 Digital Input	[0] No operation	All set-ups	TRUE	-	Uint8
5-14	Terminal 32 Digital Input	[0] No operation	All set-ups	TRUE	-	Uint8
5-15	Terminal 33 Digital Input	[0] No operation	All set-ups	TRUE	-	Uint8
5-16	Terminal X30/2 Digital Input	[0] No operation	All set-ups	TRUE	-	Uint8
5-17	Terminal X30/3 Digital Input	[0] No operation	All set-ups	TRUE	-	Uint8
5-18	Terminal X30/4 Digital Input	[0] No operation	All set-ups	TRUE	-	Uint8
5-3* Digital Outputs						
5-30	Terminal 27 Digital Output	[0] No operation	All set-ups	TRUE	-	Uint8
5-31	Terminal 29 Digital Output	[0] No operation	All set-ups	TRUE	-	Uint8
5-32	Term X30/6 Digi Out (MCB 101)	[0] No operation	All set-ups	TRUE	-	Uint8
5-33	Term X30/7 Digi Out (MCB 101)	[0] No operation	All set-ups	TRUE	-	Uint8
5-4* Relays						
5-40	Function Relay	[0] No operation	All set-ups	TRUE	-	Uint8
5-41	On Delay, Relay	0.01 s	All set-ups	TRUE	-2	Uint16
5-42	Off Delay, Relay	0.01 s	All set-ups	TRUE	-2	Uint16
5-5* Pulse Input						
5-50	Term. 29 Low Frequency	100 Hz	All set-ups	TRUE	0	Uint32
5-51	Term. 29 High Frequency	100 Hz	All set-ups	TRUE	0	Uint32
5-52	Term. 29 Low Ref./Feedb. Value	0.000 N/A	All set-ups	TRUE	-3	Int32
5-53	Term. 29 High Ref./Feedb. Value	100.000 N/A	All set-ups	TRUE	-3	Int32
5-54	Pulse Filter Time Constant #29	100 ms	All set-ups	FALSE	-3	Uint16
5-55	Term. 33 Low Frequency	100 Hz	All set-ups	TRUE	0	Uint32
5-56	Term. 33 High Frequency	100 Hz	All set-ups	TRUE	0	Uint32
5-57	Term. 33 Low Ref./Feedb. Value	0.000 N/A	All set-ups	TRUE	-3	Int32
5-58	Term. 33 High Ref./Feedb. Value	100.000 N/A	All set-ups	TRUE	-3	Int32
5-59	Pulse Filter Time Constant #33	100 ms	All set-ups	FALSE	-3	Uint16
5-6* Pulse Output						
5-60	Terminal 27 Pulse Output Variable	[0] No operation	All set-ups	TRUE	-	Uint8
5-62	Pulse Output Max Freq #27	5000 Hz	All set-ups	TRUE	0	Uint32
5-63	Terminal 29 Pulse Output Variable	[0] No operation	All set-ups	TRUE	-	Uint8
5-65	Pulse Output Max Freq #29	5000 Hz	All set-ups	TRUE	0	Uint32
5-66	Terminal X30/6 Pulse Output Variable	[0] No operation	All set-ups	TRUE	-	Uint8
5-68	Pulse Output Max Freq #X30/6	5000 Hz	All set-ups	TRUE	0	Uint32

Par. No. #	Parameter description	Default value	4 set-up	Change during operation	Conversion index	Type
5-9* Bus Controlled						
5-90	Digital & Relay Bus Control	0 N/A	All set-ups	TRUE	0	Ujnt32
5-93	Pulse Out #27 Bus Control	0.00 %	All set-ups	TRUE	-2	N2
5-94	Pulse Out #27 Timeout Preset	0.00 %	1 set-up	TRUE	-2	Ujnt16
5-95	Pulse Out #29 Bus Control	0.00 %	All set-ups	TRUE	-2	N2
5-96	Pulse Out #29 Timeout Preset	0.00 %	1 set-up	TRUE	-2	Ujnt16
5-97	Pulse Out #X30/6 Bus Control	0.00 %	All set-ups	TRUE	-2	N2
5-98	Pulse Out #X30/6 Timeout Preset	0.00 %	1 set-up	TRUE	-2	Ujnt16

4.2.8. 6-**- Analog In/Out

Par. No. #	Parameter description	Default value	4 set-up	Change during operation	Conversion index	Type
6-0* Analog I/O Mode						
6-00	Live Zero Timeout Time	10 s	All set-ups	TRUE	0	Uint8
6-01	Live Zero Timeout Function	[0] Off	All set-ups	TRUE	-	Uint8
6-02	Fire Mode Live Zero Timeout Function	null	All set-ups	TRUE	-	Uint8
6-1* Analog Input 53						
6-10	Terminal 53 Low Voltage	0.07 V	All set-ups	TRUE	-2	Int16
6-11	Terminal 53 High Voltage	10.00 V	All set-ups	TRUE	-2	Int16
6-12	Terminal 53 Low Current	4.00 mA	All set-ups	TRUE	-5	Int16
6-13	Terminal 53 High Current	20.00 mA	All set-ups	TRUE	-5	Int16
6-14	Terminal 53 Low Ref./Feedb. Value	0.000 N/A	All set-ups	TRUE	-3	Int32
6-15	Terminal 53 High Ref./Feedb. Value	SR	All set-ups	TRUE	-3	Int32
6-16	Terminal 53 Filter Time Constant	0.001 s	All set-ups	TRUE	-3	Uuint16
6-17	Terminal 53 Live Zero	[1] Enabled	All set-ups	TRUE	-	Uuint8
6-2* Analog Input 54						
6-20	Terminal 54 Low Voltage	0.07 V	All set-ups	TRUE	-2	Int16
6-21	Terminal 54 High Voltage	10.00 V	All set-ups	TRUE	-2	Int16
6-22	Terminal 54 Low Current	4.00 mA	All set-ups	TRUE	-5	Int16
6-23	Terminal 54 High Current	20.00 mA	All set-ups	TRUE	-5	Int16
6-24	Terminal 54 Low Ref./Feedb. Value	0.000 N/A	All set-ups	TRUE	-3	Int32
6-25	Terminal 54 High Ref./Feedb. Value	100.000 N/A	All set-ups	TRUE	-3	Int32
6-26	Terminal 54 Filter Time Constant	0.001 s	All set-ups	TRUE	-3	Uuint16
6-27	Terminal 54 Live Zero	[1] Enabled	All set-ups	TRUE	-	Uuint8
6-3* Analog Input X30/11						
6-30	Terminal X30/11 Low Voltage	0.07 V	All set-ups	TRUE	-2	Int16
6-31	Terminal X30/11 High Voltage	10.00 V	All set-ups	TRUE	-2	Int16
6-34	Term. X30/11 Low Ref./Feedb. Value	0.000 N/A	All set-ups	TRUE	-3	Int32
6-35	Term. X30/11 High Ref./Feedb. Value	100.000 N/A	All set-ups	TRUE	-3	Int32
6-36	Term. X30/11 Filter Time Constant	0.001 s	All set-ups	TRUE	-3	Uuint16
6-37	Term. X30/11 Live Zero	[1] Enabled	All set-ups	TRUE	-	Uuint8
6-4* Analog Input X30/12						
6-40	Terminal X30/12 Low Voltage	0.07 V	All set-ups	TRUE	-2	Int16
6-41	Terminal X30/12 High Voltage	10.00 V	All set-ups	TRUE	-2	Int16
6-44	Term. X30/12 Low Ref./Feedb. Value	0.000 N/A	All set-ups	TRUE	-3	Int32
6-45	Term. X30/12 High Ref./Feedb. Value	100.000 N/A	All set-ups	TRUE	-3	Int32
6-46	Term. X30/12 Filter Time Constant	0.001 s	All set-ups	TRUE	-3	Uuint16
6-47	Term. X30/12 Live Zero	[1] Enabled	All set-ups	TRUE	-	Uuint8
6-5* Analog Output 42						
6-50	Terminal 42 Output	[100] Output frequency	All set-ups	TRUE	-	Uuint8
6-51	Terminal 42 Output Min Scale	0.00 %	All set-ups	TRUE	-2	Int16
6-52	Terminal 42 Output Max Scale	100.00 %	All set-ups	TRUE	-2	Int16
6-53	Terminal 42 Output Bus Control	0.00 %	All set-ups	TRUE	-2	N2
6-54	Terminal 42 Output Timeout Preset	0.00 %	1 set-up	TRUE	-2	Uuint16

Par. No. #	Parameter description	Default value	4 set-up	Change during operation	Conversion index	Type
6-6* Analog Output X30/8						
6-60	Terminal X30/8 Output	[0] No operation	All set-ups	TRUE	-	Uint8
6-61	Terminal X30/8 Min. Scale	0.00 %	All set-ups	TRUE	-2	Int16
6-62	Terminal X30/8 Max. Scale	100.00 %	All set-ups	TRUE	-2	Int16
6-63	Terminal X30/8 Output Bus Control	0.00 %	All set-ups	TRUE	-2	N2
6-64	Terminal X30/8 Output Timeout Preset	0.00 %	1 set-up	TRUE	-2	Uint16

4.2.9. 8-**-** Comm. and Options

Par. No. #	Parameter description	Default value	4 set-up	Change during operation	Conversion index	Type
8-0* General Settings						
8-01	Control Site	[0] Digital and ctrl.word	All set-ups	TRUE	-	Uint8
8-02	Control Source	[0] None	All set-ups	TRUE	-	Uint8
8-03	Control Timeout Time	SR	1 set-up	TRUE	-1	Uint32
8-04	Control Timeout Function	[0] Off	1 set-up	TRUE	-	Uint8
8-05	End-of-Timeout Function	[1] Resume set-up	1 set-up	TRUE	-	Uint8
8-06	Reset Control Timeout	[0] Do not reset	All set-ups	TRUE	-	Uint8
8-07	Diagnosis Trigger	[0] Disable	2 set-ups	TRUE	-	Uint8
8-1* Control Settings						
8-10	Control Profile	[0] FC profile	All set-ups	TRUE	-	Uint8
8-13	Configurable Status Word STW	[1] Profile Default	All set-ups	TRUE	-	Uint8
8-3* FC Port Settings						
8-30	Protocol	[0] FC	1 set-up	TRUE	-	Uint8
8-31	Address	1 N/A	1 set-up	TRUE	0	Uint8
8-32	Baud Rate	null	1 set-up	TRUE	-	Uint8
8-33	Parity / Stop Bits	null	1 set-up	TRUE	-	Uint8
8-35	Minimum Response Delay	10 ms	1 set-up	TRUE	-3	Uint16
8-36	Max Response Delay	SR	1 set-up	TRUE	-3	Uint16
8-37	Max Inter-Char Delay	SR	1 set-up	TRUE	-5	Uint16
8-4* FC MC protocol set						
8-40	Telegram Selection	[1] Standard telegram 1	2 set-ups	TRUE	-	Uint8
8-5* Digital/Bus						
8-50	Coasting Select	[3] Logic OR	All set-ups	TRUE	-	Uint8
8-52	DC Brake Select	[3] Logic OR	All set-ups	TRUE	-	Uint8
8-53	Start Select	[3] Logic OR	All set-ups	TRUE	-	Uint8
8-54	Reversing Select	[0] Digital input	All set-ups	TRUE	-	Uint8
8-55	Set-up Select	[3] Logic OR	All set-ups	TRUE	-	Uint8
8-56	Preset Reference Select	[3] Logic OR	All set-ups	TRUE	-	Uint8
8-7* BACnet						
8-70	BACnet Device Instance	1 N/A	1 set-up	TRUE	0	Uint32
8-72	MS/TP Max Masters	127 N/A	1 set-up	TRUE	0	Uint8
8-73	MS/TP Max Info Frames	1 N/A	1 set-up	TRUE	0	Uint16
8-74	"I-Am" Service	[0] Send at power-up	1 set-up	TRUE	-	Uint8
8-75	Initialization Password	0 N/A	1 set-up	TRUE	0	VsStrf[20]
8-8* FC Port Diagnostics						
8-80	Bus Message Count	0 N/A	All set-ups	TRUE	0	Uint32
8-81	Bus Error Count	0 N/A	All set-ups	TRUE	0	Uint32
8-82	Slave Message Count	0 N/A	All set-ups	TRUE	0	Uint32
8-83	Slave Error Count	0 N/A	All set-ups	TRUE	0	Uint32
8-9* Bus Jog/Feedback						
8-90	Bus Jog 1 Speed	100 RPM	All set-ups	TRUE	67	Uint16
8-91	Bus Jog 2 Speed	200 RPM	All set-ups	TRUE	67	Uint16
8-94	Bus Feedback 1	0 N/A	1 set-up	TRUE	0	N2
8-95	Bus Feedback 2	0 N/A	1 set-up	TRUE	0	N2
8-96	Bus Feedback 3	0 N/A	1 set-up	TRUE	0	N2

4.2.10. 9-**-** Profibus

Par. No. #	Parameter description	Default value	4 set-up	Change during operation	Conversion index	Type
9-00	Setpoint	0 N/A	All set-ups	TRUE	0	Uint16
9-07	Actual Value	0 N/A	All set-ups	FALSE	0	Uint16
9-15	PCD Write Configuration	SR	2 set-ups	TRUE	-	Uint16
9-16	PCD Read Configuration	SR	2 set-ups	TRUE	-	Uint16
9-18	Node Address	126 N/A	1 set-up	TRUE	0	Uint8
9-22	Telegram Selection	[108] PPO 8	1 set-up	TRUE	-	Uint8
9-23	Parameters for Signals	0	All set-ups	TRUE	-	Uint16
9-27	Parameter Edit	[1] Enabled	2 set-ups	FALSE	-	Uint16
9-28	Process Control	[1] Enable cyclic master	2 set-ups	FALSE	-	Uint8
9-44	Fault Message Counter	0 N/A	All set-ups	TRUE	0	Uint16
9-45	Fault Code	0 N/A	All set-ups	TRUE	0	Uint16
9-47	Fault Number	0 N/A	All set-ups	TRUE	0	Uint16
9-52	Fault Situation Counter	0 N/A	All set-ups	TRUE	0	Uint16
9-53	Profibus Warning Word	0 N/A	All set-ups	TRUE	0	V2
9-63	Actual Baud Rate	[255] No baud rate found	All set-ups	TRUE	-	Uint8
9-64	Device Identification	0 N/A	All set-ups	TRUE	0	Uint16
9-65	Profile Number	0 N/A	All set-ups	TRUE	0	OctStr[2]
9-67	Control Word 1	0 N/A	All set-ups	TRUE	0	V2
9-68	Status Word 1	0 N/A	All set-ups	TRUE	0	V2
9-71	Profibus Save Data Values	[0] Off	All set-ups	TRUE	-	Uint8
9-72	ProfibusDriveReset	[0] No action	1 set-up	FALSE	-	Uint8
9-80	Defined Parameters (1)	0 N/A	All set-ups	FALSE	0	Uint16
9-81	Defined Parameters (2)	0 N/A	All set-ups	FALSE	0	Uint16
9-82	Defined Parameters (3)	0 N/A	All set-ups	FALSE	0	Uint16
9-83	Defined Parameters (4)	0 N/A	All set-ups	FALSE	0	Uint16
9-84	Defined Parameters (5)	0 N/A	All set-ups	FALSE	0	Uint16
9-90	Changed Parameters (1)	0 N/A	All set-ups	FALSE	0	Uint16
9-91	Changed Parameters (2)	0 N/A	All set-ups	FALSE	0	Uint16
9-92	Changed Parameters (3)	0 N/A	All set-ups	FALSE	0	Uint16
9-93	Changed Parameters (4)	0 N/A	All set-ups	FALSE	0	Uint16
9-94	Changed Parameters (5)	0 N/A	All set-ups	FALSE	0	Uint16

4.2.11. 10-*CAN Ser. Com. Bus

Par. No. #	Parameter description	Default value	4 set-up	Change during operation	Conversion index	Type
10-0* Common Settings						
10-00	CAN Protocol	null	2 set-ups	FALSE	-	Uint8
10-01	Baud Rate Select	null	2 set-ups	TRUE	-	Uint8
10-02	MAC ID	SR	2 set-ups	TRUE	0	Uint8
10-05	Readout Transmit Error Counter	0 N/A	All set-ups	TRUE	0	Uint8
10-06	Readout Receive Error Counter	0 N/A	All set-ups	TRUE	0	Uint8
10-07	Readout Bus Off Counter	0 N/A	All set-ups	TRUE	0	Uint8
10-1* DeviceNet						
10-10	Process Data Type Selection	null	All set-ups	TRUE	-	Uint8
10-11	Process Data Config Write	SR	2 set-ups	TRUE	-	Uint16
10-12	Process Data Config Read	SR	2 set-ups	TRUE	-	Uint16
10-13	Warning Parameter	0 N/A	All set-ups	TRUE	0	Uint16
10-14	Net Reference	[0] Off	2 set-ups	TRUE	-	Uint8
10-15	Net Control	[0] Off	2 set-ups	TRUE	-	Uint8
10-2* COS Filters						
10-20	COS Filter 1	0 N/A	All set-ups	FALSE	0	Uint16
10-21	COS Filter 2	0 N/A	All set-ups	FALSE	0	Uint16
10-22	COS Filter 3	0 N/A	All set-ups	FALSE	0	Uint16
10-23	COS Filter 4	0 N/A	All set-ups	FALSE	0	Uint16
10-3* Parameter Access						
10-30	Array Index	0 N/A	2 set-ups	TRUE	0	Uint8
10-31	Store Data Values	[0] Off	All set-ups	TRUE	-	Uint8
10-32	DeviceNet Revision	SR	All set-ups	TRUE	0	Uint16
10-33	Store Always	[0] Off	1 set-up	TRUE	-	Uint8
10-34	DeviceNet Product Code	120 N/A	1 set-up	TRUE	0	Uint16
10-39	DeviceNet F Parameters	0 N/A	All set-ups	TRUE	0	Uint32

4.2.12. 13-** Smart Logic

Par. No. #	Parameter description	Default value	4 set-up	Change during operation	Conversion Index	Type
13-0* SLC Settings						
13-00	SL Controller Mode	null	2 set-ups	TRUE	-	Uint8
13-01	Start Event	null	2 set-ups	TRUE	-	Uint8
13-02	Stop Event	null	2 set-ups	TRUE	-	Uint8
13-03	Reset SLC	[0] Do not reset SLC	All set-ups	TRUE	-	Uint8
13-1* Comparators						
13-10	Comparator Operand	null	2 set-ups	TRUE	-	Uint8
13-11	Comparator Operator	null	2 set-ups	TRUE	-	Uint8
13-12	Comparator Value	SR	2 set-ups	TRUE	-3	Int32
13-2* Timers						
13-20	SL Controller Timer	SR	1 set-up	TRUE	-3	TimD
13-4* Logic Rules						
13-40	Logic Rule Boolean 1	null	2 set-ups	TRUE	-	Uint8
13-41	Logic Rule Operator 1	null	2 set-ups	TRUE	-	Uint8
13-42	Logic Rule Boolean 2	null	2 set-ups	TRUE	-	Uint8
13-43	Logic Rule Operator 2	null	2 set-ups	TRUE	-	Uint8
13-44	Logic Rule Boolean 3	null	2 set-ups	TRUE	-	Uint8
13-5* States						
13-51	SL Controller Event	null	2 set-ups	TRUE	-	Uint8
13-52	SL Controller Action	null	2 set-ups	TRUE	-	Uint8

4.2.13. 14-* Special Functions

Par. No. #	Parameter description	Default value	4 set-up	Change during operation	Conversion index	Type
14-0* Inverter Switching						
14-00	Switching Pattern	[0] 60 AVM	All set-ups	TRUE	-	Uint8
14-01	Switching Frequency	null	All set-ups	TRUE	-	Uint8
14-03	Overmodulation	[1] On	All set-ups	FALSE	-	Uint8
14-04	PWM Random	[0] Off	All set-ups	TRUE	-	Uint8
14-1* Line Supply On/Off						
14-12	Function at Line Imbalance	[3] Derate	All set-ups	TRUE	-	Uint8
14-2* Reset Functions						
14-20	Reset Mode	[10] Automatic reset x 10	All set-ups	TRUE	-	Uint8
14-21	Automatic Restart Time	10 s	All set-ups	TRUE	0	Uint16
14-22	Operation Mode	[0] Normal operation	All set-ups	TRUE	-	Uint8
14-23	Typecode Setting	null	2 set-ups	FALSE	-	Uint16
14-25	Trip Delay at Torque Limit	60 s	All set-ups	TRUE	0	Uint8
14-26	Trip Delay at Inverter Fault	SR	All set-ups	TRUE	0	Uint8
14-28	Production Settings	[0] No action	All set-ups	TRUE	-	Uint8
14-29	Service Code	0 N/A	All set-ups	TRUE	0	Int32
14-3* Current Limit Ctrl.						
14-30	Current Lim Ctrl, Proportional Gain	100 %	All set-ups	FALSE	0	Uint16
14-31	Current Lim Ctrl, Integration Time	0.020 s	All set-ups	FALSE	-3	Uint16
14-4* Energy Optimizing						
14-40	VT Level	66 %	All set-ups	FALSE	0	Uint8
14-41	AEO Minimum Magnetization	40 %	All set-ups	TRUE	0	Uint8
14-42	Minimum AEO Frequency	10 Hz	All set-ups	TRUE	0	Uint8
14-43	Motor Cos-Phi	SR	All set-ups	TRUE	-2	Uint16
14-5* Environment						
14-50	RFI Filter	[1] On	1 set-up	FALSE	-	Uint8
14-52	Fan Control	[0] Auto	All set-ups	TRUE	-	Uint8
14-53	Fan Monitor	[1] Warning	All set-ups	TRUE	-	Uint8
14-6* Auto Derate						
14-60	Function at Overtemperature	[1] Derate	All set-ups	TRUE	-	Uint8
14-61	Function at Inverter Overload	[1] Derate	All set-ups	TRUE	-	Uint8
14-62	Inv. Overload Derate Current	95 %	All set-ups	TRUE	0	Uint16

4.2.14. 15-**-** FC Information

Par. No. #	Parameter description	Default value	4 set-up	Change during operation	Conversion index	Type
15-0* Operating Data						
15-00	Operating Hours	0 h	All set-ups	FALSE	74	Uint32
15-01	Running Hours	0 h	All set-ups	FALSE	74	Uint32
15-02	KWh Counter	0 KWh	All set-ups	FALSE	75	Uint32
15-03	Power-ups	0 N/A	All set-ups	FALSE	0	Uint32
15-04	Overtmps	0 N/A	All set-ups	FALSE	0	Uint16
15-05	Overtolts	0 N/A	All set-ups	FALSE	0	Uint16
15-06	Reset KWh Counter	[0] Do not reset	All set-ups	TRUE	-	Uint8
15-07	Reset Running Hours Counter	[0] Do not reset	All set-ups	TRUE	-	Uint8
15-08	Number of Starts	0 N/A	All set-ups	FALSE	0	Uint32
15-1* Data Log Settings						
15-10	Logging Source	0	2 set-ups	TRUE	-	Uint16
15-11	Logging Interval	SR	2 set-ups	TRUE	-3	TimD
15-12	Trigger Event	[0] False	1 set-up	TRUE	-	Uint8
15-13	Logging Mode	[0] Log always	2 set-ups	TRUE	-	Uint8
15-14	Samples Before Trigger	50 N/A	2 set-ups	TRUE	0	Uint8
15-2* Historic Log						
15-20	Historic Log: Event	0 N/A	All set-ups	FALSE	0	Uint8
15-21	Historic Log: Value	0 N/A	All set-ups	FALSE	0	Uint32
15-22	Historic Log: Time	0 ms	All set-ups	FALSE	-3	Uint32
15-23	Historic Log: Date and Time	SR	All set-ups	FALSE	0	TimeOfDay
15-3* Alarm Log						
15-30	Alarm Log: Error Code	0 N/A	All set-ups	FALSE	0	Uint8
15-31	Alarm Log: Value	0 N/A	All set-ups	FALSE	0	Int16
15-32	Alarm Log: Time	0 s	All set-ups	FALSE	0	Uint32
15-33	Alarm Log: Date and Time	SR	All set-ups	FALSE	0	TimeOfDay
15-4* Drive Identification						
15-40	FC Type	0 N/A	All set-ups	FALSE	0	VisStr[6]
15-41	Power Section	0 N/A	All set-ups	FALSE	0	VisStr[20]
15-42	Voltage	0 N/A	All set-ups	FALSE	0	VisStr[20]
15-43	Software Version	0 N/A	All set-ups	FALSE	0	VisStr[5]
15-44	Ordered Typecode String	0 N/A	All set-ups	FALSE	0	VisStr[40]
15-45	Actual Typecode String	0 N/A	All set-ups	FALSE	0	VisStr[40]
15-46	Adjustable Frequency Drive Ordering No.	0 N/A	All set-ups	FALSE	0	VisStr[8]
15-47	Power Card Ordering No.	0 N/A	All set-ups	FALSE	0	VisStr[8]
15-48	LCP ID No	0 N/A	All set-ups	FALSE	0	VisStr[20]
15-49	SW ID Control Card	0 N/A	All set-ups	FALSE	0	VisStr[20]
15-50	SW ID Power Card	0 N/A	All set-ups	FALSE	0	VisStr[20]
15-51	Adjustable Frequency Drive Serial Number	0 N/A	All set-ups	FALSE	0	VisStr[10]
15-53	Power Card Serial Number	0 N/A	All set-ups	FALSE	0	VisStr[19]

Par. No. #	Parameter description	Default value	4 set-up	Change during operation	Conversion index	Type
15-6* Option Ident						
15-60	Option Mounted	0 N/A	All set-ups	FALSE	0	VisStr[30]
15-61	Option SW Version	0 N/A	All set-ups	FALSE	0	VisStr[20]
15-62	Option Ordering No	0 N/A	All set-ups	FALSE	0	VisStr[8]
15-63	Option Serial No	0 N/A	All set-ups	FALSE	0	VisStr[18]
15-70	Option in Slot A	0 N/A	All set-ups	FALSE	0	VisStr[30]
15-71	Slot A Option SW Version	0 N/A	All set-ups	FALSE	0	VisStr[20]
15-72	Option in Slot B	0 N/A	All set-ups	FALSE	0	VisStr[30]
15-73	Slot B Option SW Version	0 N/A	All set-ups	FALSE	0	VisStr[20]
15-74	Option in Slot C0	0 N/A	All set-ups	FALSE	0	VisStr[30]
15-75	Slot C0 Option SW Version	0 N/A	All set-ups	FALSE	0	VisStr[20]
15-76	Option in Slot C1	0 N/A	All set-ups	FALSE	0	VisStr[30]
15-77	Slot C1 Option SW Version	0 N/A	All set-ups	FALSE	0	VisStr[20]
15-9* Parameter Info						
15-92	Defined Parameters	0 N/A	All set-ups	FALSE	0	Ujnt16
15-93	Modified Parameters	0 N/A	All set-ups	FALSE	0	Ujnt16
15-99	Parameter Metadata	0 N/A	All set-ups	FALSE	0	Ujnt16

4.2.15. 16-** Data Readouts

Par. No. #	Parameter description	Default value	4 set-up	Change during operation	Conversion index	Type
16-0* General Status						
16-00	Control Word	0 N/A	All set-ups	FALSE	0	V2
16-01	Reference [Unit]	0.000 ReferenceFeedbackUnit	All set-ups	FALSE	-3	Int32
16-02	Reference [%]	0.0 %	All set-ups	FALSE	-1	Int16
16-03	Status Word	0 N/A	All set-ups	FALSE	0	V2
16-05	Main Actual Value [%]	0.00 %	All set-ups	FALSE	-2	N2
16-09	Custom Readout	0.00 CustomReadoutUnit	All set-ups	FALSE	-2	Int32
16-1* Motor Status						
16-10	Power [kW]	0.00 kW	All set-ups	FALSE	1	Int32
16-11	Power [hp]	0.00 hp	All set-ups	FALSE	-2	Int32
16-12	Motor Voltage	0.0 V	All set-ups	FALSE	-1	Umt16
16-13	Frequency	0.0 Hz	All set-ups	FALSE	-1	Umt16
16-14	Motor Current	0.00 A	All set-ups	FALSE	-2	Int32
16-15	Frequency [%]	0.00 %	All set-ups	FALSE	-2	N2
16-16	Torque [Nm]	0.0 Nm	All set-ups	FALSE	-1	Int16
16-17	Speed [RPM]	0 RPM	All set-ups	FALSE	67	Int32
16-18	Motor Thermal	0 %	All set-ups	FALSE	0	Umt8
16-22	Torque [%]	0 %	All set-ups	FALSE	0	Int16
16-3* Drive Status						
16-30	DC Link Voltage	0 V	All set-ups	FALSE	0	Umt16
16-32	Braking Energy /s	0.000 kW	All set-ups	FALSE	0	Umt32
16-33	Brake Energy/2 min	0.000 kW	All set-ups	FALSE	0	Umt32
16-34	Heatsink Temp.	32° F [0° C]	All set-ups	FALSE	100	Umt8
16-35	Inverter Thermal	0 %	All set-ups	FALSE	0	Umt8
16-36	Inv. Nom. Current	SR	All set-ups	FALSE	-2	Umt32
16-37	Inv. Max. Current	SR	All set-ups	FALSE	-2	Umt32
16-38	SL Controller State	0 N/A	All set-ups	FALSE	0	Umt8
16-39	Control Card Temp.	32° F [0° C]	All set-ups	FALSE	100	Umt8
16-40	Logging Buffer Full	[0] No	All set-ups	TRUE	-	Umt8
16-5* Ref. & Feeds.						
16-50	External Reference	0.0 N/A	All set-ups	FALSE	-1	Int16
16-52	Feedback [Unit]	0.000 ProcessCtrlUnit	All set-ups	FALSE	-3	Int32
16-53	DigiPot Reference	0.00 N/A	All set-ups	FALSE	-2	Int16
16-54	Feedback 1 [Unit]	0.000 ProcessCtrlUnit	All set-ups	FALSE	-3	Int32
16-55	Feedback 2 [Unit]	0.000 ProcessCtrlUnit	All set-ups	FALSE	-3	Int32
16-56	Feedback 3 [Unit]	0.000 ProcessCtrlUnit	All set-ups	FALSE	-3	Int32
16-59	Adjusted Setpoint		All set-ups	FALSE	-3	Int32

Par. No. #	Parameter description	Default value	4 set-up	Change during operation	Conversion index	Type
16-6* Inputs & Outputs						
16-60	Digital Input	0 N/A	All set-ups	FALSE	0	Uimt16
16-61	Terminal 53 Switch Setting	[0] Current	All set-ups	FALSE	-	Uimt8
16-62	Analog Input 53	0.000 N/A	All set-ups	FALSE	-3	Int32
16-63	Terminal 54 Switch Setting	[0] Current	All set-ups	FALSE	-	Uimt8
16-64	Analog Input 54	0.000 N/A	All set-ups	FALSE	-3	Int32
16-65	Analog Output 42 [mA]	0.000 N/A	All set-ups	FALSE	-3	Int16
16-66	Digital Output [bin]	0 N/A	All set-ups	FALSE	0	Int16
16-67	Pulse Input #29 [Hz]	0 N/A	All set-ups	FALSE	0	Int32
16-68	Pulse Input #33 [Hz]	0 N/A	All set-ups	FALSE	0	Int32
16-69	Pulse Output #27 [Hz]	0 N/A	All set-ups	FALSE	0	Int32
16-70	Pulse Output #29 [Hz]	0 N/A	All set-ups	FALSE	0	Int32
16-71	Relay Output [bin]	0 N/A	All set-ups	FALSE	0	Int16
16-72	Counter A	0 N/A	All set-ups	TRUE	0	Int32
16-73	Counter B	0 N/A	All set-ups	TRUE	0	Int32
16-75	Analog In X30/11	0.000 N/A	All set-ups	FALSE	-3	Int32
16-76	Analog In X30/12	0.000 N/A	All set-ups	FALSE	-3	Int32
16-77	Analog Out X30/8 [mA]	0.000 N/A	All set-ups	FALSE	-3	Int16
16-8* Ser. Com. Bus & FC Port						
16-80	Ser. Com. Bus CTW 1	0 N/A	All set-ups	FALSE	0	V2
16-82	Ser. com. bus REF 1	0 N/A	All set-ups	FALSE	0	N2
16-84	Comm. Option STW	0 N/A	All set-ups	FALSE	0	V2
16-85	FC Port CTW 1	0 N/A	All set-ups	FALSE	0	V2
16-86	FC Port REF 1	0 N/A	All set-ups	FALSE	0	N2
16-9* Diagnosis Readouts						
16-90	Alarm Word	0 N/A	All set-ups	FALSE	0	Uimt32
16-91	Alarm Word 2	0 N/A	All set-ups	FALSE	0	Uimt32
16-92	Warning Word	0 N/A	All set-ups	FALSE	0	Uimt32
16-93	Warning Word 2	0 N/A	All set-ups	FALSE	0	Uimt32
16-94	Ext. Status Word	0 N/A	All set-ups	FALSE	0	Uimt32
16-95	Ext. Status Word 2	0 N/A	All set-ups	FALSE	0	Uimt32
16-96	Maintenance Word	0 N/A	All set-ups	FALSE	0	Uimt32

4.2.16. 18-** Data Readouts 2

Par. No. #	Parameter description	Default value	4 set-up	Change during operation	Conversion index	Type
18-0* Maintenance Log						
18-00	Maintenance Log: Item	0 N/A	All set-ups	FALSE	0	UInt8
18-01	Maintenance Log: Action	0 N/A	All set-ups	FALSE	0	UInt8
18-02	Maintenance Log: Time	0 s	All set-ups	FALSE	0	UInt32
18-03	Maintenance Log: Date and Time	SR	All set-ups	FALSE	0	TimeOfDay
18-3* Inputs & Outputs						
18-30	Analog Input X42/1	0.000 N/A	All set-ups	FALSE	-3	Int32
18-31	Analog Input X42/3	0.000 N/A	All set-ups	FALSE	-3	Int32
18-32	Analog Input X42/5	0.000 N/A	All set-ups	FALSE	-3	Int32
18-33	Analog Out X42/7 [V]	0.000 N/A	All set-ups	FALSE	-3	Int16
18-34	Analog Out X42/9 [V]	0.000 N/A	All set-ups	FALSE	-3	Int16
18-35	Analog Out X42/11 [V]	0.000 N/A	All set-ups	FALSE	-3	Int16

4.2.17. 20-* * FC Closed-loop

Par. No. #	Parameter description	Default value	4 set-up	Change during operation	Conversion index	Type
20-0* Feedback						
20-00	Feedback 1 Source	[2] Analog input 54	All set-ups	TRUE	-	Uint8
20-03	Feedback 2 Source	[0] No function	All set-ups	TRUE	-	Uint8
20-06	Feedback 3 Source	[0] No function	All set-ups	TRUE	-	Uint8
20-07	Feedback 3 Conversion	[0] Linear	All set-ups	TRUE	-	-
20-09	Feedback 4 Source	[0] No function	All set-ups	TRUE	-	Uint8
20-11	Feedback 4 Source Unit	null	All set-ups	TRUE	-	Uint8
20-12	Reference/Feedback Unit	null	All set-ups	TRUE	-	Uint8
20-2* Feedback & Setpoint						
20-20	Feedback Function	[4] Maximum	All set-ups	TRUE	-	Uint8
20-21	Setpoint 1	0.000 ProcessCtrlUnit	All set-ups	TRUE	-3	Int32
20-22	Setpoint 2	0.000 ProcessCtrlUnit	All set-ups	TRUE	-3	Int32
20-23	Setpoint 3	0.000 ProcessCtrlUnit	All set-ups	TRUE	-3	Int32
20-37* PID Auto-tuning						
20-70	Closed-loop Type	Auto	All set-ups	TRUE	-	-
20-71	PID Output Change	0.10	All set-ups	TRUE	-	-
20-72	Minimum Feedback Level	0.000 User Units	All set-ups	TRUE	-	-
20-73	Maximum Feedback Level	0.000 User Units	All set-ups	TRUE	-	-
20-74	Tuning Mode	Normal	All set-ups	TRUE	-	-
20-75	PID Auto-tuning	Disabled	All set-ups	TRUE	-	-
20-8* PID Basic Settings						
20-81	PID Normal/ Inverse Control	[0] Normal	All set-ups	TRUE	-	Uint8
20-82	PID Start Speed [RPM]	SR	All set-ups	TRUE	67	Uint16
20-83	PID Start Speed [Hz]	SR	All set-ups	TRUE	-1	Uint16
20-84	On Reference Bandwidth	5 %	All set-ups	TRUE	0	Uint8
20-9* PID Controller						
20-91	PID Anti Windup	[1] On	All set-ups	TRUE	-	Uint8
20-93	PID Proportional Gain	0.50 N/A	All set-ups	TRUE	-2	Uint16
20-94	PID Integral Time	20.00 s	All set-ups	TRUE	-2	Uint32
20-95	PID Differentiation Time	0.00 s	All set-ups	TRUE	-2	Uint16
20-96	PID Diff. Gain Limit	5.0 N/A	All set-ups	TRUE	-1	Uint16

4.2.18. 21-1-** Ext. Closed-loop

Par. No. #	Parameter description	Default value	4 set-up	Change during operation	Conversion index	Type
21-1* Ext. CL 1 Ref./Fb.						
21-10	Ext. 1 Ref./Feedback Unit	[0]	All set-ups	TRUE	-	Uint8
21-11	Ext. 1 Minimum Reference	0.000 ExtPID1Unit	All set-ups	TRUE	-3	Int32
21-12	Ext. 1 Maximum Reference	100.000 ExtPID1Unit	All set-ups	TRUE	-3	Int32
21-13	Ext. 1 Reference Source	[0] No function	All set-ups	TRUE	-	Uint8
21-14	Ext. 1 Feedback Source	[0] No function	All set-ups	TRUE	-	Uint8
21-15	Ext. 1 Setpoint	0.000 ExtPID1Unit	All set-ups	TRUE	-3	Int32
21-17	Ext. 1 Reference [Unit]	0.000 ExtPID1Unit	All set-ups	TRUE	-3	Int32
21-18	Ext. 1 Feedback [Unit]	0.000 ExtPID1Unit	All set-ups	TRUE	-3	Int32
21-19	Ext. 1 Output [%]	0 %	All set-ups	TRUE	0	Int32
21-2* Ext. CL 1 PID						
21-20	Ext. 1 Normal/Inverse Control	[0] Normal	All set-ups	TRUE	-	Uint8
21-21	Ext. 1 Proportional Gain	0.5	All set-ups	TRUE	-2	Uint16
21-22	Ext. 1 Integral Time	20.0 s	All set-ups	TRUE	-2	Uint32
21-23	Ext. 1 Differentiation Time	0.00 s	All set-ups	TRUE	-2	Uint16
21-24	Ext. 1 Dif. Gain Limit	5.0 N/A	All set-ups	TRUE	-1	Uint16
21-3* Ext. CL 2 Ref./Fb.						
21-30	Ext. 2 Ref./Feedback Unit	[0]	All set-ups	TRUE	-	Uint8
21-31	Ext. 2 Minimum Reference	0.000 ExtPID2Unit	All set-ups	TRUE	-3	Int32
21-32	Ext. 2 Maximum Reference	100.000 ExtPID2Unit	All set-ups	TRUE	-3	Int32
21-33	Ext. 2 Reference Source	[0] No function	All set-ups	TRUE	-	Uint8
21-34	Ext. 2 Feedback Source	[0] No function	All set-ups	TRUE	-	Uint8
21-35	Ext. 2 Setpoint	0.000 ExtPID2Unit	All set-ups	TRUE	-3	Int32
21-37	Ext. 2 Reference [Unit]	0.000 ExtPID2Unit	All set-ups	TRUE	-3	Int32
21-38	Ext. 2 Feedback [Unit]	0.000 ExtPID2Unit	All set-ups	TRUE	-3	Int32
21-39	Ext. 2 Output [%]	0 %	All set-ups	TRUE	0	Int32
21-4* Ext. CL 2 PID						
21-40	Ext. 2 Normal/Inverse Control	[0] Normal	All set-ups	TRUE	-	Uint8
21-41	Ext. 2 Proportional Gain	0.5	All set-ups	TRUE	-2	Uint16
21-42	Ext. 2 Integral Time	20.0 s	All set-ups	TRUE	-2	Uint32
21-43	Ext. 2 Differentiation Time	0.00 s	All set-ups	TRUE	-2	Uint16
21-44	Ext. 2 Dif. Gain Limit	5.0 N/A	All set-ups	TRUE	-1	Uint16
21-5* Ext. CL 3 Ref./Fb.						
21-50	Ext. 3 Ref./Feedback Unit	[0]	All set-ups	TRUE	-	Uint8
21-51	Ext. 3 Minimum Reference	0.000 ExtPID3Unit	All set-ups	TRUE	-3	Int32
21-52	Ext. 3 Maximum Reference	100.000 ExtPID3Unit	All set-ups	TRUE	-3	Int32
21-53	Ext. 3 Reference Source	[0] No function	All set-ups	TRUE	-	Uint8
21-54	Ext. 3 Feedback Source	[0] No function	All set-ups	TRUE	-	Uint8
21-55	Ext. 3 Setpoint	0.000 ExtPID3Unit	All set-ups	TRUE	-3	Int32
21-57	Ext. 3 Reference [Unit]	0.000 ExtPID3Unit	All set-ups	TRUE	-3	Int32
21-58	Ext. 3 Feedback [Unit]	0.000 ExtPID3Unit	All set-ups	TRUE	-3	Int32
21-59	Ext. 3 Output [%]	0 %	All set-ups	TRUE	0	Int32

Par. No. #	Parameter description	Default value	4 set-up	FC 302 only	Change during operation	Conver- sion index	Type
21-6*	Ext. CL 3 PID						
21-60	Ext.: 3 Normal/Inverse Control	[0] Normal	All set-ups		TRUE	-	Uint8
21-61	Ext.: 3 Proportional Gain	0.5	All set-ups		TRUE	-2	Uint16
21-62	Ext.: 3 Integral Time	20.0 s	All set-ups		TRUE	-2	Uint32
21-63	Ext.: 3 Differentiation Time	0.00 s	All set-ups		TRUE	-2	Uint16
21-64	Ext.: 3 Dif. Gain Limit	5.0 N/A	All set-ups		TRUE	-1	Uint16

4.2.19. 22-2** Application Functions

Par. No. #	Parameter description	Default value	4 set-up	Change during operation	Conversion index	Type
22-0* Miscellaneous						
22-00	External Interlock Delay	0 s	All set-ups	TRUE	0	Ujnt16
22-2* No-Flow Detection						
22-20	Low Power Auto Set-up	[0] Off	All set-ups	FALSE	-	Ujnt8
22-21	Low Power Detection	[0] Disabled	All set-ups	TRUE	-	Ujnt8
22-22	Low Speed Detection	[0] Disabled	All set-ups	TRUE	-	Ujnt8
22-23	No-Flow Function	[0] Off	All set-ups	TRUE	-	Ujnt8
22-24	No-Flow Delay	10 s	All set-ups	TRUE	0	Ujnt16
22-26	Dry Pump Function	[0] Off	All set-ups	TRUE	-	Ujnt8
22-27	Dry Pump Delay	10 s	All set-ups	TRUE	0	Ujnt16
22-3* No-Flow Power Tuning						
22-30	No-Flow Power	0.00 kW	All set-ups	TRUE	1	Ujnt32
22-31	Power Correction Factor	100 %	All set-ups	TRUE	0	Ujnt16
22-32	Low Speed [RPM]	SR	All set-ups	TRUE	67	Ujnt16
22-33	Low Speed [Hz]	SR	All set-ups	TRUE	-1	Ujnt16
22-34	Low Speed Power [kW]	SR	All set-ups	TRUE	1	Ujnt32
22-35	Low Speed Power [HP]	SR	All set-ups	TRUE	-2	Ujnt32
22-36	High Speed [RPM]	SR	All set-ups	TRUE	67	Ujnt16
22-37	High Speed [Hz]	SR	All set-ups	TRUE	-1	Ujnt16
22-38	High Speed Power [kW]	SR	All set-ups	TRUE	1	Ujnt32
22-39	High Speed Power [HP]	SR	All set-ups	TRUE	-2	Ujnt32
22-4* Sleep Mode						
22-40	Minimum Run Time	60 s	All set-ups	TRUE	0	Ujnt16
22-41	Minimum Sleep Time	30 s	All set-ups	TRUE	0	Ujnt16
22-42	Wake-up Speed [RPM]	SR	All set-ups	TRUE	67	Ujnt16
22-43	Wake-up Speed [Hz]	SR	All set-ups	TRUE	-1	Ujnt16
22-44	Wake-up Ref./FB Difference	10 %	All set-ups	TRUE	0	Int8
22-45	Setpoint Boost	0 %	All set-ups	TRUE	0	Int8
22-46	Maximum Boost Time	60 s	All set-ups	TRUE	0	Ujnt16
22-5* End of Curve						
22-50	End of Curve Function	[0] Off	All set-ups	TRUE	-	Ujnt8
22-51	End of Curve Delay	10 s	All set-ups	TRUE	0	Ujnt16
22-6* Broken Belt Detection						
22-60	Broken Belt Function	[0] Off	All set-ups	TRUE	-	Ujnt8
22-61	Broken Belt Torque	10 %	All set-ups	TRUE	0	Ujnt8
22-62	Broken Belt Delay	10 s	All set-ups	TRUE	0	Ujnt16
22-7* Short Cycle Protection						
22-75	Short Cycle Protection	[0] Disabled	All set-ups	TRUE	-	Ujnt8
22-76	Interval between Starts	start_to_start_min_on_time (P2277)	All set-ups	TRUE	0	Ujnt16
22-77	Minimum Run Time	0 s	All set-ups	TRUE	0	Ujnt16

Par. No. #	Parameter description	Default value	4 set-up	Change during operation	Conversion Index	Type
22-8* Flow Compensation						
22-80	Flow Compensation	[0] Disabled	All set-ups	TRUE	-	Uint8
22-81	Square-linear Curve Approximation	100 %	All set-ups	TRUE	0	Uint8
22-82	Work Point Calculation	[0] Disabled	All set-ups	TRUE	-	Uint8
22-83	Speed at No-Flow [RPM]	SR	All set-ups	TRUE	67	Uint16
22-84	Speed at No-Flow [Hz]	SR	All set-ups	TRUE	-1	Uint16
22-85	Speed at Design Point [RPM]	SR	All set-ups	TRUE	67	Uint16
22-86	Speed at Design Point [Hz]	SR	All set-ups	TRUE	-1	Uint16
22-87	Pressure at No-Flow Speed	0.000 ReferenceFeedbackUnit	All set-ups	TRUE	-3	Int32
22-88	Pressure at Rated Speed	999999.999 ReferenceFeedbackUnit	All set-ups	TRUE	-3	Int32
22-89	Flow at Design Point	0.000 N/A	All set-ups	TRUE	-3	Int32
22-90	Flow at Rated Speed	0.000 N/A	All set-ups	TRUE	-3	Int32

4.2.20. 23-* Timed Actions

Par. No. #	Parameter description	Default value	4 set-up	Change during operation	Conversion Index	Type
23-0* Timed Actions						
23-00	ON Time	SR	2 set-ups	TRUE	0	TimeOfDay- WoDate UInt8
23-01	ON Action	[0] Disabled	2 set-ups	TRUE	-	UInt8
23-02	OFF Time	SR	2 set-ups	TRUE	0	TimeOfDay- WoDate UInt8
23-03	OFF Action	[0] Disabled	2 set-ups	TRUE	-	UInt8
23-04	Occurrence	[0] All days	2 set-ups	TRUE	-	UInt8
23-1* Maintenance						
23-10	Maintenance Item	[1] Motor bearings	1 set-up	TRUE	-	UInt8
23-11	Maintenance Action	[1] Lubricate	1 set-up	TRUE	-	UInt8
23-12	Maintenance Time Base	[0] Disabled	1 set-up	TRUE	-	UInt8
23-13	Maintenance Time Interval	1 h	1 set-up	TRUE	74	UInt32
23-14	Maintenance Date and Time	SR	1 set-up	TRUE	0	TimeOfDay
23-1* Maintenance Reset						
23-15	Reset Maintenance Word	[0] Do not reset	All set-ups	TRUE	-	UInt8
23-5* Energy Log						
23-50	Energy Log Resolution	[5] Last 24 Hours	2 set-ups	TRUE	-	UInt8
23-51	Period Start	SR	2 set-ups	TRUE	0	TimeOfDay
23-53	Energy Log	0 N/A	All set-ups	TRUE	0	UInt32
23-54	Reset Energy Log	[0] Do not reset	All set-ups	TRUE	-	UInt8
23-6* Trending						
23-60	Trend Variable	[0] Power [kW]	2 set-ups	TRUE	-	UInt8
23-61	Continuous Bin Data	0 N/A	All set-ups	TRUE	0	UInt32
23-62	Timed Bin Data	0 N/A	All set-ups	TRUE	0	UInt32
23-63	Timed Period Start	SR	2 set-ups	TRUE	0	TimeOfDay
23-64	Timed Period Stop	SR	2 set-ups	TRUE	0	TimeOfDay
23-65	Minimum Bin Value	SR	2 set-ups	TRUE	0	UInt8
23-66	Reset Continuous Bin Data	[0] Do not reset	All set-ups	TRUE	-	UInt8
23-67	Reset Timed Bin Data	[0] Do not reset	All set-ups	TRUE	-	UInt8
23-8* Payback Counter						
23-80	Power Reference Factor	100 %	2 set-ups	TRUE	0	UInt8
23-81	Energy Cost	1.00 N/A	2 set-ups	TRUE	-2	UInt32
23-82	Investment	0 N/A	2 set-ups	TRUE	0	UInt32
23-83	Energy Savings	0 kWh	All set-ups	TRUE	75	Int32
23-84	Cost Savings	0 N/A	All set-ups	TRUE	0	Int32

4.2.21. 25-** Cascade Controller

Par. No. #	Parameter description	Default value	4 set-up	Change during operation	Conversion index	Type
25-0* System Settings						
25-00	Cascade Controller	[0] Disabled	2 set-ups	FALSE	-	Uint8
25-02	Motor Start	[0] Direct on Line	2 set-ups	FALSE	-	Uint8
25-04	Pump Cycling	[0] Disabled	All set-ups	TRUE	-	Uint8
25-05	Fixed Lead Pump	[1] Yes	2 set-ups	FALSE	-	Uint8
25-06	Number of Pumps	2 N/A	2 set-ups	FALSE	0	Uint8
25-2* Bandwidth Settings						
25-20	Staging Bandwidth	10 %	All set-ups	TRUE	0	Uint8
25-21	Override Bandwidth	100 %	All set-ups	TRUE	0	Uint8
25-22	Fixed Speed Bandwidth	casco_staging_bandwidth (P2520)	All set-ups	TRUE	0	Uint8
25-23	SBW Staging Delay	15 s	All set-ups	TRUE	0	Uint16
25-24	SBW De-staging Delay	15 s	All set-ups	TRUE	0	Uint16
25-25	OBW Time	10 s	All set-ups	TRUE	0	Uint16
25-26	Destage At No-Flow	[0] Disabled	All set-ups	TRUE	-	Uint8
25-27	Stage Function	[1] Enabled	All set-ups	TRUE	-	Uint8
25-28	Stage Function Time	15 s	All set-ups	TRUE	0	Uint16
25-29	De-stage Function	[1] Enabled	All set-ups	TRUE	-	Uint8
25-30	De-stage Function Time	15 s	All set-ups	TRUE	0	Uint16
25-4* Staging Settings						
25-40	Ramp-down Delay	10.0 s	All set-ups	TRUE	-1	Uint16
25-41	Ramp-up Delay	2.0 s	All set-ups	TRUE	-1	Uint16
25-42	Staging Threshold	SR	All set-ups	TRUE	0	Uint8
25-43	De-staging Threshold	SR	All set-ups	TRUE	0	Uint8
25-44	Staging Speed [RPM]	0 RPM	All set-ups	TRUE	67	Uint16
25-45	Staging Speed [Hz]	0.0 Hz	All set-ups	TRUE	-1	Uint16
25-46	De-staging Speed [RPM]	0 RPM	All set-ups	TRUE	67	Uint16
25-47	De-staging Speed [Hz]	0.0 Hz	All set-ups	TRUE	-1	Uint16
25-5* Alternation Settings						
25-50	Lead Pump Alternation	[0] Off	All set-ups	TRUE	-	Uint8
25-51	Alternation Event	[0] External	All set-ups	TRUE	-	Uint8
25-52	Alternation Time Interval	24 h	All set-ups	TRUE	74	Uint16
25-53	Alternation Timer Value	0 N/A	All set-ups	TRUE	0	VisStr[7] TimeOfDay- WoDate
25-54	Alternation Predefined Time	SR	All set-ups	TRUE	0	Uint8
25-55	Alternate if Load < 50%	[1] Enabled	All set-ups	TRUE	-	Uint8
25-56	Staging Mode at Alternation	[0] Slow	All set-ups	TRUE	-	Uint8
25-58	Run Next Pump Delay	0.1 s	All set-ups	TRUE	-1	Uint16
25-59	Run-on Line Delay	0.5 s	All set-ups	TRUE	-1	Uint16

Par. No. #	Parameter description	Default value	4 set-up	Change during operation	Conversion index	Type
25-8* Status						
25-80	Cascade Status	0 N/A	All set-ups	TRUE	0	VisStr[25]
25-81	Pump Status	0 N/A	All set-ups	TRUE	0	VisStr[25]
25-82	Lead Pump	0 N/A	All set-ups	TRUE	0	Uint8
25-83	Relay Status	0 N/A	All set-ups	TRUE	0	VisStr[4]
25-84	Pump ON Time	0 h	All set-ups	TRUE	74	Uint32
25-85	Relay ON Time	0 h	All set-ups	TRUE	74	Uint32
25-86	Reset Relay Counters	[0] Do not reset	All set-ups	TRUE	-	Uint8
25-9* Service						
25-90	Pump Interlock	[0] Off	All set-ups	TRUE	-	Uint8
25-91	Manual Alternation	0 N/A	All set-ups	TRUE	0	Uint8

4.2.22. 26-** Analog I/O Option MCB 109

Par. No. #	Parameter description	Default value	4 set-up	Change during operation	Conversion index	Type
26-0* Analog I/O Mode						
26-00	Terminal X42/1 Mode	[1] Voltage	All set-ups	TRUE	-	Uint8
26-01	Terminal X42/3 Mode	[1] Voltage	All set-ups	TRUE	-	Uint8
26-02	Terminal X42/5 Mode	[1] Voltage	All set-ups	TRUE	-	Uint8
26-1* Analog Input X42/1						
26-10	Terminal X42/1 Low Voltage	0.07 V	All set-ups	TRUE	-2	Int16
26-11	Terminal X42/1 High Voltage	10.00 V	All set-ups	TRUE	-2	Int16
26-14	Term. X42/1 Low Ref./Feedb. Value	0.000 N/A	All set-ups	TRUE	-3	Int32
26-15	Term. X42/1 High Ref./Feedb. Value	100.000 N/A	All set-ups	TRUE	-3	Int32
26-16	Term. X42/1 Filter Time Constant	0.001 s	All set-ups	TRUE	-3	Uint16
26-17	Term. X42/1 Live Zero	[1] Enabled	All set-ups	TRUE	-	Uint8
26-2* Analog Input X42/3						
26-20	Terminal X42/3 Low Voltage	0.07 V	All set-ups	TRUE	-2	Int16
26-21	Terminal X42/3 High Voltage	10.00 V	All set-ups	TRUE	-2	Int16
26-24	Term. X42/3 Low Ref./Feedb. Value	0.000 N/A	All set-ups	TRUE	-3	Int32
26-25	Term. X42/3 High Ref./Feedb. Value	100.000 N/A	All set-ups	TRUE	-3	Int32
26-26	Term. X42/3 Filter Time Constant	0.001 s	All set-ups	TRUE	-3	Uint16
26-27	Term. X42/3 Live Zero	[1] Enabled	All set-ups	TRUE	-	Uint8
26-3* Analog Input X42/5						
26-30	Terminal X42/5 Low Voltage	0.07 V	All set-ups	TRUE	-2	Int16
26-31	Terminal X42/5 High Voltage	10.00 V	All set-ups	TRUE	-2	Int16
26-34	Term. X42/5 Low Ref./Feedb. Value	0.000 N/A	All set-ups	TRUE	-3	Int32
26-35	Term. X42/5 High Ref./Feedb. Value	100.000 N/A	All set-ups	TRUE	-3	Int32
26-36	Term. X42/5 Filter Time Constant	0.001 s	All set-ups	TRUE	-3	Uint16
26-37	Term. X42/5 Live Zero	[1] Enabled	All set-ups	TRUE	-	Uint8
26-4* Analog Output X42/7						
26-40	Terminal X42/7 Output	[0] No operation	All set-ups	TRUE	-	Uint8
26-41	Terminal X42/7 Min. Scale	0.00 %	All set-ups	TRUE	-2	Int16
26-42	Terminal X42/7 Max. Scale	100.00 %	All set-ups	TRUE	-2	Int16
26-43	Terminal X42/7 Output Bus Control	0.00 %	All set-ups	TRUE	-2	N2
26-44	Terminal X42/7 Output Timeout Preset	0.00 %	1 set-up	TRUE	-2	Uint16
26-5* Analog Output X42/9						
26-50	Terminal X42/9 Output	[0] No operation	All set-ups	TRUE	-	Uint8
26-51	Terminal X42/9 Min. Scale	0.00 %	All set-ups	TRUE	-2	Int16
26-52	Terminal X42/9 Max. Scale	100.00 %	All set-ups	TRUE	-2	Int16
26-53	Terminal X42/9 Output Bus Control	0.00 %	All set-ups	TRUE	-2	N2
26-54	Terminal X42/9 Output Timeout Preset	0.00 %	1 set-up	TRUE	-2	Uint16
26-6* Analog Output X42/11						
26-60	Terminal X42/11 Output	[0] No operation	All set-ups	TRUE	-	Uint8
26-61	Terminal X42/11 Min. Scale	0.00 %	All set-ups	TRUE	-2	Int16
26-62	Terminal X42/11 Max. Scale	100.00 %	All set-ups	TRUE	-2	Int16
26-63	Terminal X42/11 Output Bus Control	0.00 %	All set-ups	TRUE	-2	N2
26-64	Terminal X42/11 Output Timeout Preset	0.00 %	1 set-up	TRUE	-2	Uint16

4.2.23. 29-**-** Water Application Functions

Par. No. #	Parameter description	Default value	4 set-up	Change during operation	Conversion index	Type
29-0*	Pipe Fill					
29-00	Pipe Fill Enable	Disabled	All set-ups	TRUE	-	-
29-01	Pipe Fill Speed [RPM]	Motor Speed Low Limit	All set-ups	TRUE	-	-
29-02	Pipe Fill Speed [Hz]	Motor Speed Low Limit	All set-ups	TRUE	-	-
29-03	Pipe Fill Time	0	All set-ups	TRUE	-	-
29-04	Pipe Fill Rate	-	All set-ups	TRUE	-	-
29-05	Filled Setpoint	0	All set-ups	TRUE	-	-

4.2.24. 31-**-** Bypass Option

Par. No. #	Parameter description	Default value	4 set-up	Change during operation	Conversion index	Type
31-00	Bypass Mode	[0] Drive	All set-ups	TRUE	-	Uint8
31-01	Bypass Start Time Delay	30 s	All set-ups	TRUE	0	Uint16
31-02	Bypass Trip Time Delay	0 s	All set-ups	TRUE	0	Uint16
31-03	Test Mode Activation	[0] Disabled	All set-ups	TRUE	-	Uint8
31-10	Bypass Status Word	0 N/A	All set-ups	FALSE	0	V2
31-11	Bypass Running Hours	0 h	All set-ups	FALSE	74	Uint32
31-19	Remote Bypass Activation	[0] Disabled	2 set-ups	TRUE	-	Uint8



5

5. General Specifications

Normal overload 110% for 1 minute														
Adjustable frequency drive														
Typical Shaft Output [kW]														
Typical Shaft Output [HP] at 460V														
IP 00	P160	P200	P250	P315	P355	P400	P450	IP 00	P160	P200	P250	P315		
IP 21	D3	D4	D4	E2	E2	E2	E2	IP 21	D3	D4	D4	E2		
IP 54	D1	D2	D2	E1	E1	E1	E1	IP 54	D1	D2	D2	E1		
Continuous (3 x 400 V) [A]	212	260	315	395	480	600	745	800	212	260	315	395		
Intermittent (3 x 400 V) [A]	233	286	347	435	528	660	820	880	233	286	347	435		
Continuous (3 x 460-500 V) [A]	190	240	302	361	443	540	678	730	190	240	302	361		
Intermittent (3 x 460-500 V) [A]	209	264	332	397	487	594	746	803	209	264	332	397		
Continuous kVA (400 V AC) [kVA]	147	180	218	274	333	416	516	554	147	180	218	274		
Continuous kVA (460 V AC) [kVA]	151	191	241	288	353	430	540	582	151	191	241	288		
Max. cable size:														
(line power, motor, brake) [mm ² / AWG] ²⁾	2x70		2x185		4x240				2x70		2x185		4x240	
	2x2/0		2x350 mcm		4x500 mcm				2x2/0		2x350 mcm		4x500 mcm	
Continuous (3 x 400 V) [A]	204	251	304	381	463	590	733	787	204	251	304	381	463	590
Continuous (3 x 460/500V) [A]	183	231	291	348	427	531	667	718	183	231	291	348	427	531
Max. pre-fuses ¹⁾ [A]	300	350	400	500	600	700	900	900	300	350	400	500	600	700
Environment														
Estimated power loss at rated max. load [W] ⁴⁾	3234	3782	4213	5119	5893	7630	8879	9428	3234	3782	4213	5119	5893	7630
Weight enclosure IP 00 [kg]	81.9	90.5	111.8	122.9	137.7	221.4	234.1	277.3	81.9	90.5	111.8	122.9	137.7	221.4
Weight enclosure IP 21 [kg]	95.5	104.1	125.4	136.3	151.3	263.2	270.0	313.2	95.5	104.1	125.4	136.3	151.3	263.2
Weight enclosure IP 54 [kg]	95.5	104.1	125.4	136.3	151.3	263.2	270.0	313.2	95.5	104.1	125.4	136.3	151.3	263.2
Efficiency ³⁾	0.98	0.98	0.98	0.98	0.98	0.98	0.98	0.98	0.98	0.98	0.98	0.98	0.98	0.98

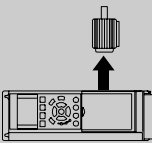

¹⁾ For type of fuse, see section *Fuses*.
²⁾ American Wire Gauge
³⁾ Measured using 16.4 ft. [5 m] shielded motor cables at rated load and rated frequency.
⁴⁾ The typical power loss is at normal load conditions and expected to be within +/- 15% (tolerance relates to variety in voltage and cable conditions). Values are based on a typical motor efficiency (eff2/eff3 border line). Lower efficiency motors will also add to the power loss in the adjustable frequency drive and vice versa. If the switching frequency is raised from nominal, the power losses may rise significantly. LCP and typical control card power consumption values are included. Further options and customer load may add up to 30 W to the losses. (though typically only 4W extra for a fully loaded control card, or options for slot A or slot B, each). Although measurements are made with state of the art equipment, some measurement inaccuracy must be allowed for (+/- 5%).



5.1.1.1. Line Supply 3 x 525-690 V AC

Normal overload 110% for 1 minute

Adjustable frequency drive	P132	P160	P200	P250	P315	P400	P450	P500	P560	P630
Typical Shaft Output [kW]	132	160	200	250	315	400	450	500	560	630
Typical Shaft Output [HP] at 575 V	175	210	265	330	420	500	550	600	700	800
IP 00	D3	D3	D4	D4	D4	D4	E2	E2	E2	E2
IP 21	D1	D1	D2	D2	D2	D2	E1	E1	E1	E1
IP 54	D1	D1	D2	D2	D2	D2	E1	E1	E1	E1

Output current

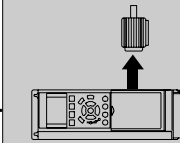

Continuous (3 x 550 V) [A]	162	201	253	303	360	418	470	523	596	630
Intermittent (3 x 550 V) [A]	178	221	278	333	396	460	517	575	656	693
Continuous (3 x 575-690 V) [A]	155	192	242	290	344	400	450	500	570	630
Intermittent (3 x 575-690 V) [A]	171	211	266	319	378	440	495	550	627	693
Continuous kVA (550 V AC) [kVA]	154	191	241	289	343	398	448	498	568	600
Continuous kVA (575 V AC) [kVA]	154	191	241	289	343	398	448	498	568	627
Continuous kVA (690 V AC) [kVA]	185	229	289	347	411	478	538	598	681	753
Max. cable size:										
(line power, motor, brake) [mm ² / AWG] ²⁾	2x70	2x185	2x350	4x240						
	2x2/0	4x500	mcm	mcm						

Max. input current

Continuous (3 x 550 V) [A]	158	198	245	299	355	408	453	504	574	607
Continuous (3 x 575 V) [A]	151	189	234	286	339	390	434	482	549	607
Continuous (3 x 690 V) [A]	155	197	240	296	352	400	434	482	549	607
Max. pre-fuses ¹⁾ [A]	225	250	350	400	500	600	700	700	900	900
Environment										
Estimated power loss at rated max. load [W] ⁴⁾	3114	3612	4293	5156	5821	6149	6449	7249	8727	9673
Weight enclosure IP 00 [kg]	81.9	90.5	111.8	122.9	137.7	151.3	221	221	236	277
Weight enclosure IP 21 [kg]	95.5	104.1	125.4	136.3	151.3	164.9	263	263	272	313
Weight enclosure IP 54 [kg]	95.5	104.1	125.4	136.3	151.3	164.9	263	263	272	313
Efficiency ³⁾	0.98	0.98	0.98	0.98	0.98	0.98	0.98	0.98	0.98	0.98

¹⁾ For type of fuse, see section *Fuses*.
²⁾ American Wire Gauge
³⁾ Measured using 16.4 ft. [5 m] shielded motor cables at rated load and rated frequency.
⁴⁾ The typical power loss is at normal load conditions and expected to be within +/- 15% (tolerance relates to variety in voltage and cable conditions). Values are based on a typical motor efficiency (eff2/eff3 border line). Lower efficiency motors will also add to the power loss in the adjustable frequency drive and vice versa. If the switching frequency is raised from nominal, the power losses may rise significantly. LCP and typical control card power consumption values are included. Further options and customer load may add up to 30 W to the losses. (though typically only 4W extra for a fully loaded control card, or options for slot A or slot B, each). Although measurements are made with state of the art equipment, some measurement inaccuracy must be allowed for (+/- 5%).

Line power supply (L1, L2, L3):

Supply voltage	380-480 V \pm 10%
Supply voltage	525-690 V \pm 10%
Supply frequency	50/60 Hz
Max. imbalance temporary between line phases	3.0% of rated supply voltage
True Power Factor (λ)	\geq 0.9 nominal at rated load
Displacement Power Factor ($\cos\phi$) near unity	(> 0.98)
Switching on input supply L1, L2, L3 (power-ups) \leq enclosure type A	maximum twice/min.
Switching on input supply L1, L2, L3 (power-ups) \geq enclosure type B, C	maximum once/min.
Switching on input supply L1, L2, L3 (power-ups) \geq enclosure type D, E	maximum once/2 min.
Environment according to EN60664-1	overvoltage category III / pollution degree 2

The unit is suitable for use on a circuit capable of delivering not more than 100,000 RMS symmetrical Amperes, 480/690 V maximum.

Motor output (U, V, W):

Output voltage	0 - 100% of supply voltage
Output frequency	0 - 1000 Hz
Switching on output	Unlimited
Ramp times	1 - 3600 sec.

Torque characteristics:

Starting torque (Constant torque)	maximum 110% for 1 min.*
Starting torque	maximum 135% up to 0.5 sec.*
Overload torque (Constant torque)	maximum 110% for 1 min.*

**Percentage relates to VLT AQUA Drive's nominal torque.*

Cable lengths and cross-sections:

Max. motor cable length, shielded/armored	VLT AQUA Drive: 492 ft [150 m]
Max. motor cable length, unshielded/unarmored	VLT AQUA Drive: 984 ft [300 m]
Max. cross-section to motor, line power, load sharing and brake *	
Maximum cross-section to control terminals, rigid wire	0.0023 in. ² [1.5 mm ²]/16 AWG (2 x 0.0012 in. ² [2 x 0.75 mm ²])
Maximum cross-section to control terminals, flexible cable	0.0016 in. ² [1 mm ²]/18 AWG
Maximum cross-section to control terminals, cable with enclosed core	0.00078 in. ² [0.5 mm ²]/20 AWG
Minimum cross-section to control terminals	0.00039 in. ² [0.25 mm ²]

** See Line Supply tables for more information!*

Digital inputs:

Programmable digital inputs	4 (6)
Terminal number	18, 19, 27 ¹⁾ , 29, 32, 33,
Logic	PNP or NPN
Voltage level	0 - 24 V DC
Voltage level, logic '0' PNP	< 5 V DC
Voltage level, logic '1' PNP	> 10 V DC
Voltage level, logic '0' NPN	> 19 V DC
Voltage level, logic '1' NPN	< 14 V DC
Maximum voltage on input	28 V DC
Input resistance, R_i	approx. 4 k Ω

All digital inputs are galvanically isolated from the supply voltage (PELV) and other high-voltage terminals.

1) Terminals 27 and 29 can also be programmed as output.

Analog inputs:

Number of analog inputs	2
Terminal number	53, 54
Modes	Voltage or current
Mode select	Switch S201 and switch S202
Voltage mode	Switch S201/switch S202 = OFF (U)
Voltage level	: 0 to + 10 V (scaleable)
Input resistance, R_i	approx. 10 k Ω
Max. voltage	\pm 20 V
Current mode	Switch S201/switch S202 = ON (I)
Current level	0/4 to 20 mA (scalable)
Input resistance, R_i	approx. 200 Ω
Max. current	30 mA
Resolution for analog inputs	10 bit (+ sign)
Accuracy of analog inputs	Max. error 0.5% of full scale
Bandwidth	: 200 Hz

The analog inputs are galvanically isolated from the supply voltage (PELV) and other high-voltage terminals.

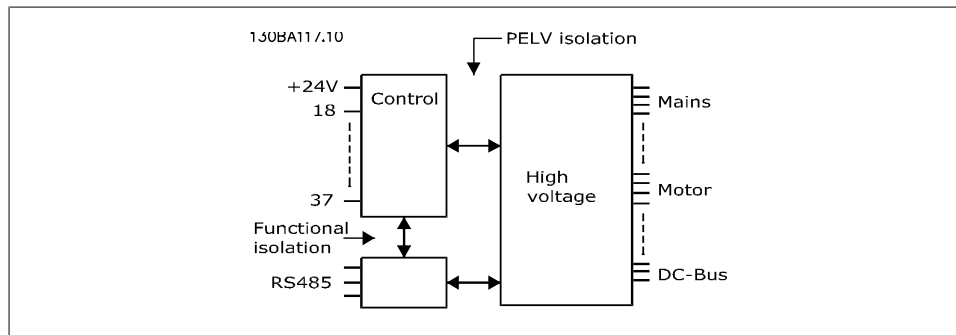

Pulse inputs:	
Programmable pulse inputs	2
Terminal number pulse	29, 33
Max. frequency at terminal, 29, 33	110 kHz (push-pull driven)
Max. frequency at terminal, 29, 33	5 kHz (open collector)
Min. frequency at terminal 29, 33	4 Hz
Voltage level	see section on Digital input
Maximum voltage on input	28 V DC
Input resistance, R_i	approx. 4 k Ω
Pulse input accuracy (0.1-1 kHz)	Max. error: 0.1% of full scale

Analog output:	
Number of programmable analog outputs	1
Terminal number	42
Current range at analog output	0/4 - 20 mA
Max. load to common at analog output	500 Ω
Accuracy on analog output	Max. error: 0.8% of full scale
Resolution on analog output	8 bit

The analog output is galvanically isolated from the supply voltage (PELV) and other high-voltage terminals.

Control card, RS-485 serial communication:	
Terminal number	68 (P,TX+, RX+), 69 (N,TX-, RX-)
Terminal number 61	Common for terminals 68 and 69

The RS-485 serial communication circuit is functionally separated from other central circuits and galvanically isolated from the supply voltage (PELV).

Digital output:	
Programmable digital/pulse outputs	2
Terminal number	27, 29 ¹⁾
Voltage level at digital/frequency output	0 - 24 V
Max. output current (sink or source)	40 mA
Max. load at frequency output	1 k Ω
Max. capacitive load at frequency output	10 nF
Minimum output frequency at frequency output	0 Hz
Maximum output frequency at frequency output	32 kHz
Accuracy of frequency output	Max. error: 0.1% of full scale
Resolution of output frequency	12 bit

1) Terminal 27 and 29 can also be programmed as input.

The digital output is galvanically isolated from the supply voltage (PELV) and other high-voltage terminals.

Control card, 24 V DC output:	
Terminal number	12, 13
Max. load	: 200 mA

The 24 V DC supply is galvanically isolated from the supply voltage (PELV), but has the same potential as the analog and digital inputs and outputs.

Relay outputs:

Programmable relay outputs	2
Relay 01 Terminal number	1-3 (break), 1-2 (make)
Max. terminal load (AC-1) ¹⁾ on 1-3 (NC), 1-2 (NO) (Resistive load)	240 V AC, 2 A
Max. terminal load (AC-15) ¹⁾ (Inductive load @ cosφ 0.4)	240 V AC, 0.2 A
Max. terminal load (DC-1) ¹⁾ on 1-2 (NO), 1-3 (NC) (Resistive load)	60 V DC, 1 A
Max. terminal load (DC-13) ¹⁾ (Inductive load)	24 V DC, 0.1 A
Relay 02 Terminal number	4-6 (break), 4-5 (make)
Max. terminal load (AC-1) ¹⁾ on 4-5 (NO) (Resistive load)	240 V AC, 2 A
Max. terminal load (AC-15) ¹⁾ on 4-5 (NO) (Inductive load @ cosφ 0.4)	240 V AC, 0.2 A
Max. terminal load (DC-1) ¹⁾ on 4-5 (NO) (Resistive load)	80 V DC, 2 A
Max. terminal load (DC-13) ¹⁾ on 4-5 (NO) (Inductive load)	24 V DC, 0.1 A
Max. terminal load (AC-1) ¹⁾ on 4-6 (NC) (Resistive load)	240 V AC, 2 A
Max. terminal load (AC-15) ¹⁾ on 4-6 (NC) (Inductive load @ cosφ 0.4)	240 V AC, 0.2 A
Max. terminal load (DC-1) ¹⁾ on 4-6 (NC) (Resistive load)	50 V DC, 2 A
Max. terminal load (DC-13) ¹⁾ on 4-6 (NC) (Inductive load)	24 V DC, 0.1 A
Min. terminal load on 1-3 (NC), 1-2 (NO), 4-6 (NC), 4-5 (NO)	24 V DC 10 mA, 24 V AC 20 mA
Environment according to EN 60664-1	overvoltage category III/pollution degree 2

1) IEC 60947 part 4 and 5

The relay contacts are galvanically isolated from the rest of the circuit by reinforced isolation (PELV).

Control card, 10 V DC output:

Terminal number	50
Output voltage	10.5 V ±0.5 V
Max. load	25 mA

The 10 V DC supply is galvanically isolated from the supply voltage (PELV) and other high-voltage terminals.

Control characteristics:

Resolution of output frequency at 0-1000 Hz	: +/- 0.003 Hz
System response time (terminals 18, 19, 27, 29, 32, 33)	: ≤ 2 ms
Speed control range (open-loop)	1:100 of synchronous speed
Speed accuracy (open-loop)	30-4000 rpm: Maximum error of ±8 rpm

All control characteristics are based on a 4-pole asynchronous motor

Surroundings:

Enclosure ≤ enclosure type D	IP 00, IP 21, IP 54
Enclosure ≥ enclosure type D, E	IP 21, IP 54
Enclosure kit available ≤ enclosure type D	IP 21/TYPE 1/IP 4X top
Vibration test	1.0 g
Max. relative humidity	5%-95% (IEC 721-3-3; Class 3K3 (non-condensing) during operation
Aggressive environment (IEC 721-3-3), uncoated	class 3C2
Aggressive environment (IEC 721-3-3), coated	class 3C3
Test method according to IEC 60068-2-43 H2S (10 days)	
Ambient temperature	Max. 113° F [45° C] (AVM switching mode only!) and max. 104° F [40° C] over a 24 hour period.
Ambient temperature	Max. 104° F [40° C] (SFAVM switching mode only!) and max. 95° F [35° C] over a 24 hour period.
<i>Derating for high ambient temperature, see the Design Guide, section on Special Conditions</i>	
Minimum ambient temperature during full-scale operation	32° F [0° C]
Minimum ambient temperature at reduced performance	14° F [-10° C]
Temperature during storage/transport	-13°-+149°/158° F [-25°-+65°/70° C]
Maximum altitude above sea level without derating	3280 ft [1000 m]
Maximum altitude above sea level with derating	9842 ft [3000 m]

Derating for high altitude, see section on special conditions.

EMC standards, Emission	EN 61800-3, EN 61000-6-3/4, EN 55011, IEC 61800-3 EN 61800-3, EN 61000-6-1/2, EN 61000-4-2, EN 61000-4-3, EN 61000-4-4, EN 61000-4-5, EN 61000-4-6
EMC standards, Immunity	61000-4-6

See section on special conditions.

Control card performance:

Scan interval	: 5 ms
---------------	--------

Control card, USB serial communication:

USB standard	1.1 (Full speed)
USB plug	USB type B "device" plug



Connection to PC is carried out via a standard host/device USB cable.
The USB connection is galvanically isolated from the supply voltage (PELV) and other high-voltage terminals.
The USB connection is not galvanically isolated from protection ground. Use only isolated laptop/PC as connection to the USB connector on VLT AQUA Drive or an isolated USB cable/drive.

Protection and Features:

- Electronic thermal motor protection against overload.
- Temperature monitoring of the heatsink ensures that the adjustable frequency drive trips if the temperature reaches $203^{\circ}\text{F} \pm 9^{\circ}\text{F}$ [$95^{\circ}\text{C} \pm 5^{\circ}\text{C}$]. An overload temperature cannot be reset until the temperature of the heatsink is below $158^{\circ}\text{C} \pm 9^{\circ}\text{C}$ [$70^{\circ}\text{C} \pm 5^{\circ}\text{C}$] (Guideline - these temperatures may vary for different power sizes, enclosures, etc.). The VLT AQUA Drive has an auto-derating function to prevent its heatsink from reaching 203°F [95°C].
- The adjustable frequency drive is protected against short-circuits on motor terminals U, V, W.
- If a line phase is missing, the adjustable frequency drive trips or issues a warning (depending on the load).
- Monitoring of the intermediate circuit voltage ensures that the adjustable frequency drive trips if the intermediate circuit voltage is too low or too high.
- The adjustable frequency drive is protected against ground faults on motor terminals U, V, W.

6. Troubleshooting

6.1. Alarms and warnings

A warning or an alarm is signaled by the relevant LED on the front of the adjustable frequency drive, indicated by a code on the display.

A warning remains active until its cause is no longer present. Under certain circumstances, operation of the motor may still be continued. Warning messages may be critical, but are not necessarily so.

In the event of an alarm, the adjustable frequency drive will have tripped. Alarms must be reset to restart operation once their cause has been rectified.

This may be done in four ways:

1. By using the [RESET] control button on the LCP control panel.
2. Via a digital input with the "Reset" function.
3. Via serial communication/optional serial communication bus.
4. By automatically resetting using the [Auto Reset] function, which is the default setting for VLT AQUA Drive, see par. 14-20 Reset Mode in the **VLT AQUA Drive Programming Guide**



NOTE

After a manual reset using the [RESET] button on the LCP, the [AUTO ON] or [HAND ON] button must be pressed to restart the motor.

If an alarm cannot be reset, the reason may be that its cause has not been rectified, or that the alarm is trip-locked (see also the table on following page).

Alarms that are trip-locked offer additional protection; this means that the line supply must be switched off before the alarm can be reset. After being switched back on, the adjustable frequency drive is no longer blocked and may be reset as described above, once the cause has been rectified.

Alarms that are not trip-locked can also be reset using the automatic reset function in parameter 14-20 (Warning: automatic wake-up is possible!)

If a warning and alarm is marked against a code in the table on the following page, this means that either a warning occurs before an alarm, or that it can be specified whether it is a warning or an alarm that is to be displayed for a given fault.

This is possible, for instance, in parameter 1-90 *Motor Thermal Protection*. After an alarm or trip, the motor carries on coasting, and the alarm and warning flash on the adjustable frequency drive. Once the problem has been rectified, only the alarm continues flashing.

No.	Description	Warn- ing	Alarm/Trip	Alarm/Trip Lock	Parameter Refer- ence
1	10 Volts low	X			
2	Live zero error	(X)	(X)		6-01
3	No motor	(X)			1-80
4	Line phase loss	(X)	(X)	(X)	14-12
5	DC link voltage high	X			
6	DC link voltage low	X			
7	DC overvoltage	X	X		
8	DC undervoltage	X	X		
9	Inverter overloaded	X	X		
10	Motor ETR overtemperature	(X)	(X)		1-90
11	Motor thermistor overtemperature	(X)	(X)		1-90
12	Torque limit	X	X		
13	Overcurrent	X	X	X	
14	Ground fault	X	X	X	
15	Hardware mismatch		X	X	
16	Short Circuit		X	X	
17	Control word timeout	(X)	(X)		8-04
25	Brake resistor short-circuited	X			
26	Brake resistor power limit	(X)	(X)		2-13
27	Brake chopper short-circuited	X	X		
28	Brake check	(X)	(X)		2-15
29	Power board overtemp.	X	X	X	
30	Motor phase U missing	(X)	(X)	(X)	4-58
31	Motor phase V missing	(X)	(X)	(X)	4-58
32	Motor phase W missing	(X)	(X)	(X)	4-58
33	Soft-charge fault		X	X	
34	Serial communication bus fault	X	X		
38	Internal fault		X	X	
47	24 V supply low	X	X	X	
48	1.8 V supply low		X	X	
50	AMA calibration failed		X		
51	AMA check U_{nom} and I_{nom}		X		
52	AMA low I_{nom}		X		
53	AMA motor too big		X		
54	AMA motor too small		X		
55	AMA parameter out of range		X		
56	AMA interrupted by user		X		
57	AMA timeout		X		
58	AMA internal fault	X	X		
59	Current limit	X			
61	Tracking Error	(X)	(X)		4-30
62	Output Frequency at Maximum Limit	X			
64	Voltage Limit	X			
65	Control Board Overtemperature	X	X	X	
66	Heatsink Temperature Low	X			
67	Option Configuration Has Changed		X		
68	Safe Stop Activated		X		
80	Drive Initialized to Default Value		X		

6.1: Alarm/Warning code list

(X) Dependent on parameter

<i>LED indication</i>	
Warning	yellow
Alarm	flashing red
Trip-locked	yellow and red

Alarm Word and Extended Status Word						
Bit	Hex	Dec	Alarm Word	Warning Word	Extended Word	Status
0	00000001	1	Brake Check	Brake Check	Ramping	
1	00000002	2	Pwr. Card Temp	Pwr. Card Temp	AMA Running	
2	00000004	4	Ground Fault	Ground Fault	Start CW/CCW	
3	00000008	8	Ctrl.Card Temp	Ctrl.Card Temp	Slow-down	
4	00000010	16	Ctrl. Word TO	Ctrl. Word TO	Catch Up	
5	00000020	32	Overcurrent	Overcurrent	Feedback High	
6	00000040	64	Torque Limit	Torque Limit	Feedback Low	
7	00000080	128	Motor Th Over	Motor Th Over	Output Current High	
8	00000100	256	Motor ETR Over	Motor ETR Over	Output Current Low	
9	00000200	512	Inverter Overld.	Inverter Overld.	Output Freq High	
10	00000400	1024	DC Undervolt	DC Undervolt	Output Freq Low	
11	00000800	2048	DC Overvolt	DC Overvolt	Brake Check OK	
12	00001000	4096	Short Circuit	DC Voltage Low	Braking Max	
13	00002000	8192	Soft-charge fault	DC Voltage High	Braking	
14	00004000	16384	Line ph. Loss	Line ph. Loss	Out of Speed Range	
15	00008000	32768	AMA Not OK	No Motor	OVC Active	
16	00010000	65536	Live Zero Error	Live Zero Error		
17	00020000	131072	Internal Fault	10 V Low		
18	00040000	262144	Brake Overload	Brake Overload		
19	00080000	524288	U-phase Loss	Brake Resistor		
20	00100000	1048576	V-phase Loss	Brake IGBT		
21	00200000	2097152	W-phase Loss	Speed Limit		
22	00400000	4194304	Ser. com. bus fault	Ser. com. bus fault		
23	00800000	8388608	24 V Supply Low	24 V Supply Low		
24	01000000	16777216	Line Failure	Line Failure		
25	02000000	33554432	1.8 V Supply Low	Current Limit		
26	04000000	67108864	Brake Resistor	Low Temp		
27	08000000	134217728	Brake IGBT	Voltage Limit		
28	10000000	268435456	Option Change	Unused		
29	20000000	536870912	Drive Initialized	Unused		
30	40000000	1073741824	Safe Stop	Unused		

6.2: Description of Alarm Word, Warning Word and Extended Status Word

The alarm words, warning words and extended status words can be read out for diagnosis via serial bus or optional serial communication bus. See also par. 16-90, 16-92 and 16-94.

6.1.1. Warning/Alarm list

WARNING 1, 10 Volts low:

The 10 V voltage from terminal 50 on the control card is below 10 V.

Remove a portion of the load from terminal 50, as the 10 v supply is overloaded. Max. 15 mA or minimum 590 ohm.

WARNING/ALARM 2, Live zero error:

The signal on terminal 53 or 54 is less than 50% of the value set in par. 6-10, 6-12, 6-20 or 6-22, respectively.

WARNING/ALARM 3, No motor:

No motor has been connected to the output of the adjustable frequency drive.

WARNING/ALARM 4, Line phase loss:

A phase is missing on the supply side, or the line voltage imbalance is too high.

This message also appears in case of a fault in the input rectifier on the adjustable frequency drive.

Check the supply voltage and supply currents to the adjustable frequency drive.

WARNING 5, DC link voltage high:

The intermediate circuit voltage (DC) is higher than the overvoltage limit of the control system. The adjustable frequency drive is still active.

WARNING 6, DC link voltage low

The intermediate circuit voltage (DC) is below the undervoltage limit of the control system. The adjustable frequency drive is still active.

WARNING/ALARM 7, DC overvoltage:

If the intermediate circuit voltage exceeds the limit, the adjustable frequency drive trips after a given period of time.

Connect a brake resistor. Extend the ramp time

Possible corrections:

Connect a brake resistor

Extend the ramp time

Activate functions in par. 2-10

Increase par. 14-26

Alarm/warning limits:			
Voltage ranges	3 x 200-240 V	3 x 380-480 V	3 x 525-600 V
	[VDC]	[VDC]	[VDC]
Undervoltage	185	373	532
Voltage warning low	205	410	585
Voltage warning high (w/o brake - w/brake)	390/405	810/840	943/965
Overvoltage	410	855	975

The voltages stated are the intermediate circuit voltage of the adjustable frequency drive with a tolerance of $\pm 5\%$. The corresponding AC line voltage is the intermediate circuit voltage (DC link) divided by 1.35.

WARNING/ALARM 8, DC undervoltage:

If the intermediate circuit voltage (DC) drops below the "voltage warning low" limit (see table above), the adjustable frequency drive checks if 24 V backup supply is connected.

If no 24 V backup supply is connected, the adjustable frequency drive trips after a given period of time, depending on the unit.

To check whether the supply voltage matches the adjustable frequency drive, see *Specifications*.

WARNING/ALARM 9, Inverter overloaded:

The adjustable frequency drive is about to cut out because of an overload (too high current for too long). The counter for electronic, thermal inverter protection gives a warning at

98% and trips at 100%, while giving an alarm. Reset cannot be performed before counter is below 90%.

The fault is that the adjustable frequency drive is overloaded by more than 100% for too long.

WARNING/ALARM 10, Motor ETR over-temperature:

According to the electronic thermal protection (ETR), the motor is too hot. It can be chosen if the adjustable frequency drive is to give a warning or an alarm when the counter reaches 100% in par. 1-90. The fault is that the motor is overloaded by more than 100% for too long. Check that the motor par. 1-24 is set correctly.

WARNING/ALARM 11, Motor thermistor overtemp:

The thermistor or the thermistor connection is disconnected. Decide whether the adjustable frequency drive is to give a warning or an alarm when the counter reaches 100% in par. 1-90. Make sure the thermistor is connected correctly between terminal 53 or 54 (analog voltage input) and terminal 50 (+10 V supply), or between terminal 18 or 19 (digital input PNP only) and terminal 50. If a KTY sensor is used, check for correct connection between terminal 54 and 55.

WARNING/ALARM 12, Torque limit:

The torque is higher than the value in par. 4-16 (in motor operation), or the torque is higher than the value in par. 4-17 (in regenerative operation).

WARNING/ALARM 13, Overcurrent:

The inverter peak current limit (approximately 200% of the rated current) is exceeded. The warning will last approximately 8-12 sec., then the adjustable frequency drive trips and issues an alarm. Turn off the adjustable frequency drive and check if the motor shaft can be turned and if the motor size matches the adjustable frequency drive.

ALARM 14, Ground fault:

There is a discharge from the output phases to ground, either in the cable between the adjustable frequency drive and the motor or in the motor itself.

Turn off the adjustable frequency drive and remove the ground fault.

ALARM 15, Incomplete hardware:

A fitted option is not handled by the present control board (hardware or software).

ALARM 16, Short-circuit:

There is a short-circuit in the motor or on the motor terminals.

Turn off the adjustable frequency drive and remove the short-circuit.

WARNING/ALARM 17, Control word timeout:

There is no communication to the adjustable frequency drive.

The warning will only be active when par. 8-04 is NOT set to *OFF*.

If par. 8-04 is set to *Stop* and *Trip*, a warning appears and the adjustable frequency drive ramps down until it trips, while giving an alarm.

par. 8-03 *Control word Timeout Time* could possibly be increased.

WARNING 25, Brake resistor short-circuited:

The brake resistor is monitored during operation. If it short-circuits, the brake function is disconnected and the warning appears. The adjustable frequency drive still works, but without the brake function. Turn off the adjustable frequency drive and replace the brake resistor (see par. 2-15 *Brake Check*).

ALARM/WARNING 26, Brake resistor power limit:

The power transmitted to the brake resistor is calculated as a percentage, as a mean value over the last 120 s based on the resistance value of the brake resistor (par. 2-11) and the intermediate circuit voltage. The warning is active when the dissipated braking energy is higher than 90%. If *Trip* [2] has been selected in par. 2-13, the adjustable frequency drive cuts out and issues this alarm when the dissipated braking energy is higher than 100%.

WARNING 27, Brake chopper fault:

The brake transistor is monitored during operation, and if it short-circuits, the brake function disconnects and the warning is issued. The adjustable frequency drive is still able to run, but since the brake transistor has short-circuited, substantial power is transmitted to the brake resistor, even if it is inactive. Turn off the adjustable frequency drive and remove the brake resistor.



Warning: There is a risk of substantial power being transmitted to the brake resistor if the brake transistor is short-circuited.

ALARM/WARNING 28, Brake check failed:

Brake resistor fault: the brake resistor is not connected/working.

ALARM 29, Adjustable frequency drive overtemperature:

If the enclosure is IP 20 or IP 21/TYPE 1, the cut-out temperature of the heatsink is 203° F +9° F [95° C +5° C], depending on the size of the adjustable frequency drive. The temperature fault cannot be reset until the temperature of the heatsink is below 158° C +5° C [70° C +5° C].

The fault could be a result of:

- Ambient temperature too high
- Motor cable too long

ALARM 30, Motor phase U missing:

Motor phase U between the adjustable frequency drive and the motor is missing.

Turn off the adjustable frequency drive and check motor phase U.

ALARM 31, Motor phase V missing:

Motor phase V between the adjustable frequency drive and the motor is missing.

Turn off the adjustable frequency drive and check motor phase V.

ALARM 32, Motor phase W missing:

Motor phase W between the adjustable frequency drive and the motor is missing.

Turn off the adjustable frequency drive and check motor phase W.

ALARM 33, Soft-charge fault:

Too many power-ups have occurred within a short time period. See the chapter *Specifications* for the allowed number of power-ups within one minute.

WARNING/ALARM 34, Serial communication bus fault:

The serial communication bus on the communication option card is not working.

WARNING 35, Out of frequency range:

This warning is issued if the output frequency has reached its *Warning speed low* (par. 4-52) or *Warning speed high* (par. 4-53). If the adjustable frequency drive is in *Process control*, closed-loop (par. 1-00), the warning is active in the display. If the adjustable frequency drive is not in this mode, bit 008000 *Out of frequency range* in extended status word is active but there is no warning in the display.

ALARM 38, Internal fault:

Contact the local Danfoss supplier.

WARNING 47, 24 V supply low:

The external 24 V DC back-up power supply may be overloaded; otherwise, contact your local Danfoss supplier.

WARNING 48, 1.8 V supply low:

Contact the local Danfoss supplier.

ALARM 50, AMA calibration failed:

Contact the local Danfoss supplier.

ALARM 51, AMA check Unom and Inom:

The setting of motor voltage, motor current and motor power is presumably wrong. Check the settings.

ALARM 52, AMA low Inom:

The motor current is too low. Check the settings.

ALARM 53, AMA motor too big:

The motor is too big for the AMA to be carried out.

ALARM 54, AMA motor too small:

The motor is too small for the AMA to be carried out.

ALARM 55, AMA par. out of range:

The par. values found from the motor are outside the acceptable range.

ALARM 56, AMA interrupted by user:

The AMA has been interrupted by the user.

ALARM 57, AMA timeout:

Try to start the AMA again a number of times until it is carried out. Please note that repeated runs may heat the motor to a level where the resistances R_s and R_r are increased. In most cases, however, this is not critical.

ALARM 58, AMA internal fault:

Contact the local Danfoss supplier.

WARNING 59, Current limit:

Contact the local Danfoss supplier.

WARNING 62, Output Frequency at Maximum Limit:

The output frequency is higher than the value set in par. 4-19.

WARNING 64, Voltage Limit:

The load and speed combinations demand a motor voltage higher than the actual DC link voltage.

WARNING/ALARM/TRIP 65, Control Card Overtemperature:

Control card overtemperature: The cut-out temperature of the control card is 176° F [80° C].

WARNING 66, Heatsink Temperature Low:

The heatsink temperature is measured as 32° F [0° C]. This could indicate that the temperature sensor is defective and thus the fan speed is increased to the maximum if the power part or the control card is very hot.

ALARM 67, Option Configuration has Changed:

One or more options has either been added or removed since the last power-down.

ALARM 68, Safe Stop Activated:

Safe Stop has been activated. To resume normal operation, apply 24 V DC to terminal 37, then send a reset signal (via bus, digital I/O, or by pressing [RESET]). For correct and safe use of the Safe Stop function, follow the related information and instructions in the Design Guide

ALARM 70, Illegal Frequency Configuration:

Current combination of control board and power board is illegal.

ALARM 80, Initialization to Default Value:

Parameter settings are initialized to default setting after a manual (three-finger) reset.

7. Annexes

7.1.1. Mechanical Dimensions

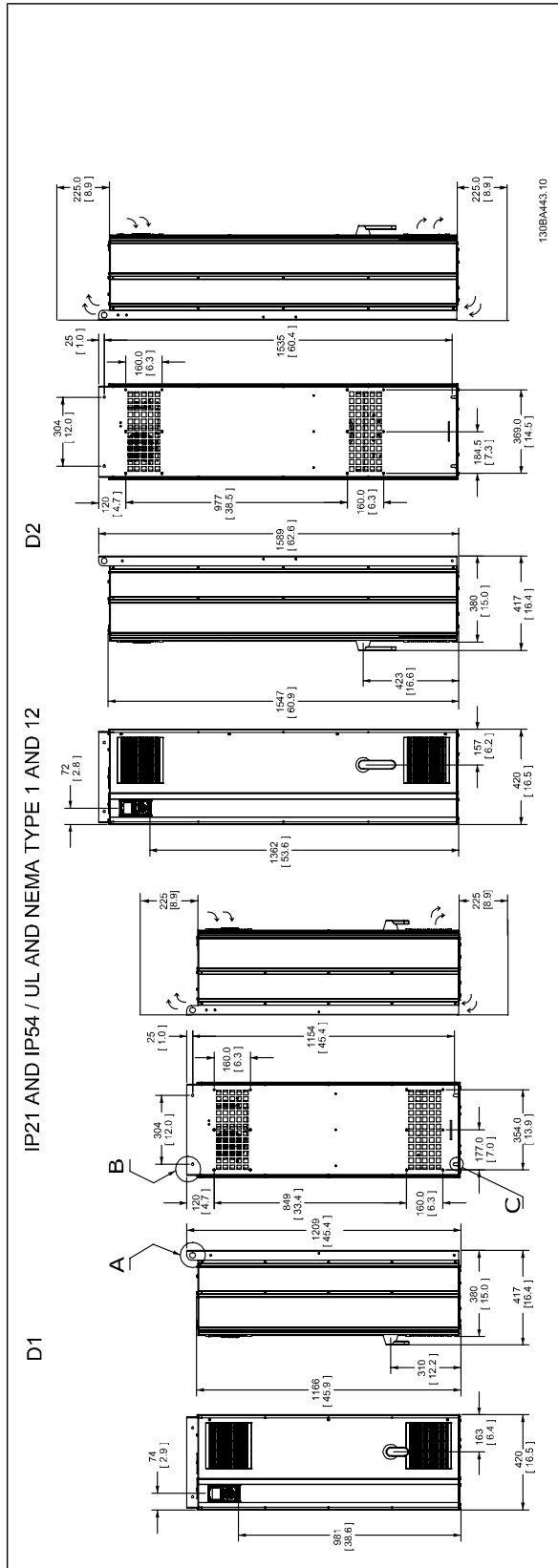

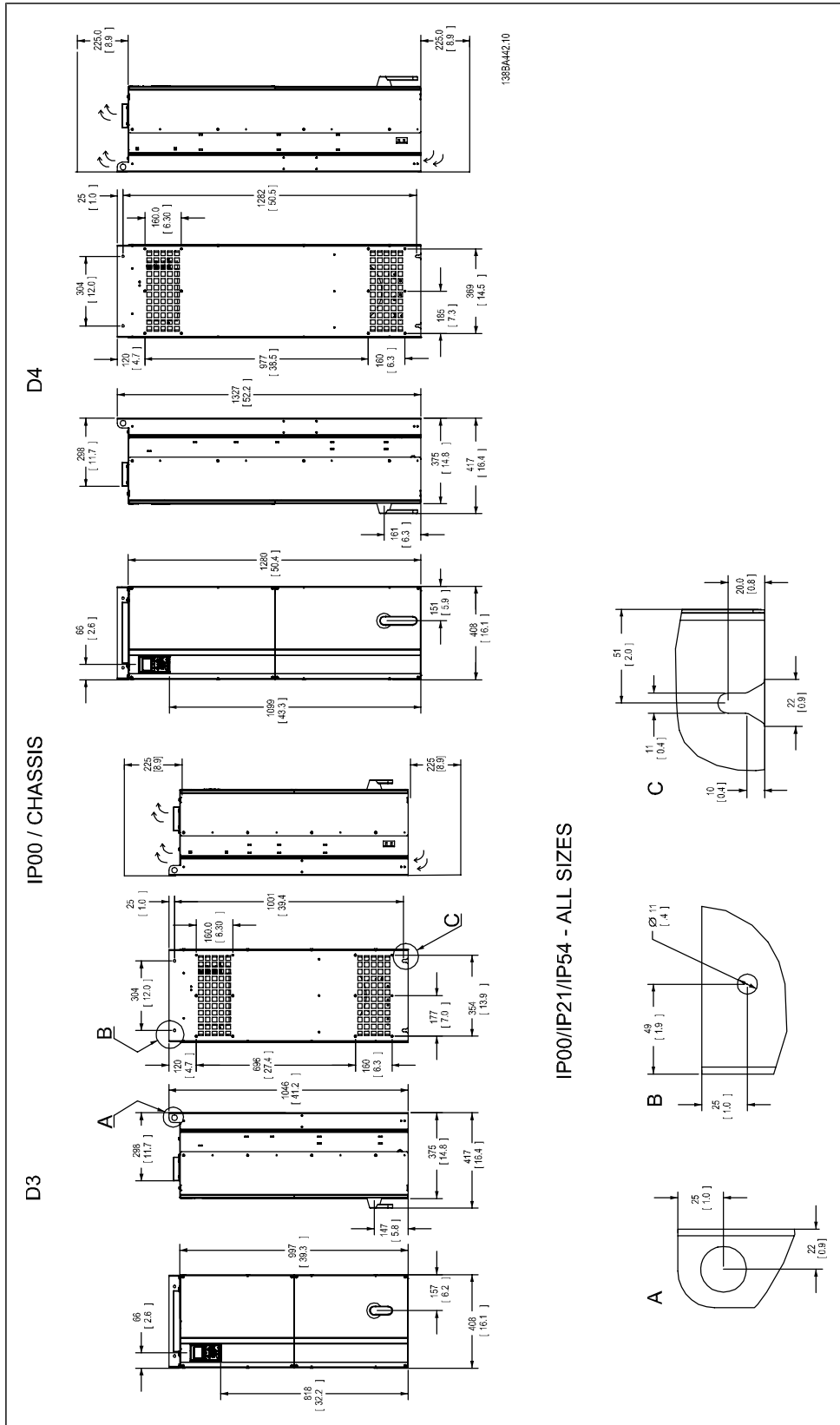

7

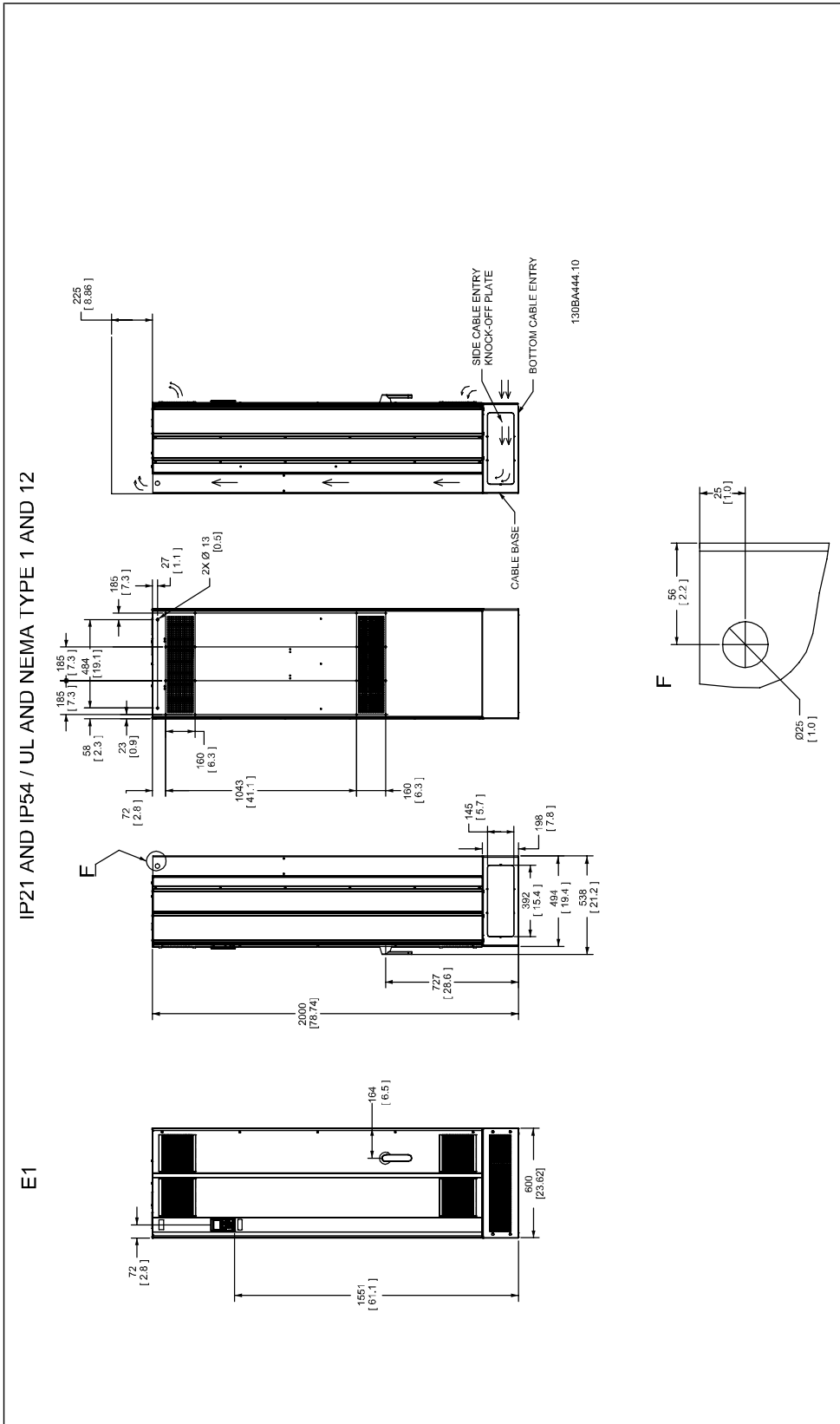

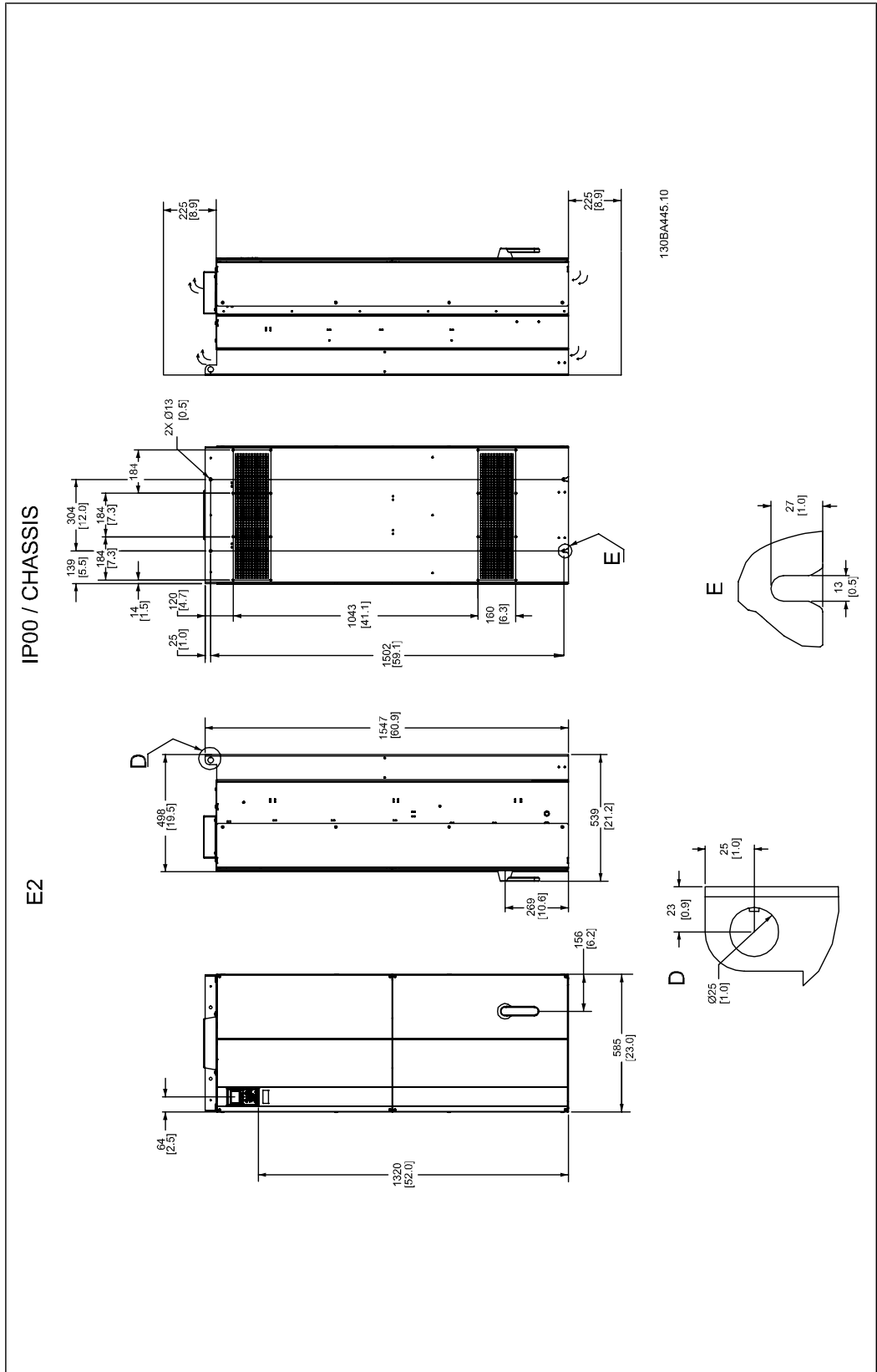



Index

0

0-** Operation/display	101
------------------------------	-----

1

1-** Load/motor	103
13-** Smart Logic	114
14-** Special Functions	115
15-** Fc Information	116
16-** Data Readouts	118
18-** Data Readouts 2	120

2

2-** Brakes	104
20-** Fc Closed-loop	121
21-** Ext. Closed-loop	122
22-** Application Functions	124
23-** Timed Actions	126
25-** Cascade Controller	127

3

3-** Reference / Ramps	105
------------------------------	-----

4

4-** Limits / Warnings	106
------------------------------	-----

5

5-** Digital In/out	107
---------------------------	-----

6

6-** Analog In/out	109
--------------------------	-----

8

8-** Comm. And Options	111
------------------------------	-----

9

9-** Profibus	112
---------------------	-----

A

Acceleration Time	74
Access To Control Terminals	60
Airflow	27
Ama	68
Analog Inputs	136
Analog Output	137
Automatic Motor Adaptation (ama)	67, 75

B

Back Cooling	29
Brake Cable	55
Brake Resistor Temperature Switch	59
Branch Circuit Protection	57

C

Cable Length And Cross-section:	48
Cable Lengths And Cross-sections	135
Cable Positions	23
Cabling	47
Changing A Group Of Numeric Data Values	97
Changing A Text Value	97
Changing Data	97
Changing Data Value	98
Communication Option	145
Configuration Mode, 1-00	85
Control Cable Routing	46
Control Cables	65
Control Cables	64
Control Card Performance	139
Control Card, +10 V Dc Output	138
Control Card, 24 V Dc Output	137
Control Card, Rs-485 Serial Communication	137
Control Card, Usb Serial Communication	139
Control Characteristics	138
Control Terminals	60
Cooling	27

D

Dc Link	143
Default Settings	100
Default Settings	99
Digital Inputs:	136
Digital Output	137
Display Line 1.2 Small, 0-21	82
Display Line 1.3 Small, 0-22	82
Display Line 2 Large, 0-23	83
Display Line 3 Large, 0-24	83
Display Text 2, 0-38	83
Display Text 3, 0-39	83
Disposal Instructions	13
Drip Shield Installation	33
Dst/summertime Start, 0-76	85
Duct Cooling	28
Duct Kit Ordering Numbers	28
Duct Work Cooling Kits	33

E

Efficient Parameter Set-up For Water Applications	72
Elcb Relays	53
Electrical Installation	60, 64
Electronic Waste	13
Etr	144
External Fan Supply	57

F

Floor Mounting	30
Function Relay, 5-40	86
Function Set-ups	76
Fuse Tables	58
Fuses	57
Fusing	47

G

General Considerations	20
General Warning	6
Grounding	52

I

Indexed Parameters	98
Initialization	99
Input Polarity Of Control Terminals	65
Installation At High Altitudes	7
Installation Of 24 Volt External Dc Supply	46
Installation Of Rittal Enclosures	34
Installation On Pedestal	43
Installation On The Wall - Ip 21 (nema 1) And Ip 54 (nema 12) Units	29
Intermediate Circuit	143
It Line Power	53

K

Kit Contents	34
Kty Sensor	144

L

Language	73
Leakage Current	8
Lifting	17
Line Connection	56
Line Power Supply (L1, L2, L3):	135
Live Zero Timeout Function, 6-01	89
Live Zero Timeout Time, 6-00	88
Load Sharing	55

M

Main Menu	71
Main Menu Mode	96
Main Reactance	75
Manual Initialization	99
Maximum Reference, 3-03	85
Mechanical Dimensions	19
Mechanical Dimensions	148
Mechanical Installation	20
Motor Cable	54
Motor Current	74
Motor Frequency, 1-23	73
Motor Nameplate	67
Motor Nominal Speed, 1-25	74
Motor Output	135
Motor Power [kw], 1-20	73
Motor Protection	140
Motor Speed High Limit [rpm], 4-13	75
Motor Speed Low Limit Rpm, 4-11	75
Motor Thermal Protection	69
Motor Voltage	73
Motor Voltage, 1-22	73

N

Nameplate Data	67
----------------	----

O

Ordering	34
Output Performance (u, V, W)	135
Overcurrent Protection	57

P

Parallel Connection Of Motors	69
Parameter Options	100
Parameter Selection	96
Parameter Set-up	71
Pedestal Installation	30
Pid Integral Time, 20-94	95
Pid Normal/inverse Control, 20-81	95, 98
Pid Proportional Gain, 20-93	95
Pid Start Speed [rpm], 20-82	95
Planning The Installation Site	16
Potentiometer Reference	63
Power Connections	47
Preset Reference	86
Protection And Features	140
Pulse Inputs	136
Pulse Start/stop	62

Q

Quick Menu	71, 72
------------	--------

R

Ramp 1 Ramp-down Time, 3-42	74
Ramp-up Time 1 Parameter, 3-41	74
Receiving The Adjustable Frequency Drive	16
Reference/feedback Unit, 20-12	93
Relay Outputs	137
Required Tools:	43
Residual Current Device	8
Rfi Switch	53

S

Safe Stop Installation	10
Safety Category 3 (en 954-1)	10
Safety Note	7
Serial Communication	139
Serial Communication Bus Connection	46
Set Date And Time, 0-70	84
Setpoint 1, 20-21	94
Shielded Cables	54
Shielded/armored	65
Shielding Of Cables:	48
Short-circuit Protection	57
Sine-wave Filter	48
Space	20
Speed Up/slow	63
Start/stop	62
Stator Leakage Reactance	75
Step-by-step	98
Stopping Category 0 (en 60204-1)	10
Surroundings	139
Switches S201, S202, And S801	66

Switching Frequency:	48
T	
Terminal 32 Digital Input, 5-14	86
Terminal 33 Digital Input, 5-15	86
Terminal 42 Output Min Scale, 6-51	92
Terminal 42 Output, 6-50	91
Terminal 53 High Voltage, 6-11	90
Terminal 53 Low Voltage, 6-10	89
Terminal Locations	21, 23
Torque	53
Torque Characteristics	135
Torque For Terminals	54
U	
Unpacking	16
V	
Voltage Level	136
Voltage Reference Via A Potentiometer	63
W	
Warning Against Unintended Start	7
Wire Access	21



www.danfoss.com/drives

Danfoss shall not be responsible for any errors in catalogs, brochures or other printed material. Danfoss reserves the right to alter its products at any time without notice, provided that alterations to products already on order shall not require material changes in specifications previously agreed upon by Danfoss and the Purchaser. All trademarks in this material are property of the respective companies. Danfoss and the Danfoss logotype are trademarks of Danfoss A/S. All rights reserved.

For: Industrial Sales, Application Engineering

Danfoss Drives

Division of Danfoss Inc.
4401 N. Bell School Road
Loves Park, IL. 61111
Toll free: 800/432-6367
Telephone: 815/639-8600
Fax: 815/639-8000
www.namc.danfoss.com

For: HVAC Sales, Water Sales, Engineered Panels

Danfoss Graham and Danfoss US Water

Division of Danfoss Inc.
8800 W. Bradley Road
Milwaukee, WI. 53224
Toll free: 800/621-8806
Telephone: 414/355-8800
Fax: 414/355-6117
www.namc.danfoss.com

