

Danfoss



High Power Instruction Manual



VLT® AutomationDrive FC 300



design award
winner
2004

Contents

1. How to Read the Instruction Manual	3
How to Read the Instruction Manual	3
Approvals	4
Symbols	4
Abbreviations	5
2. Safety Instructions and General Warning	7
Disposal Instructions	7
High Voltage	8
Safety Instructions	8
Avoid Unintended Start	9
Safe Stop	10
Safe Stop Installation	11
IT Line	11
3. How to Install	13
How to Get Started	13
Pre-installation	14
Planning the Installation Site	14
Receiving the Adjustable Frequency Drive	14
Transportation and Unpacking	14
Lifting	15
Rated Power	21
Mechanical Installation	22
Tools Needed	22
General Considerations	22
Installation in Enclosures - IP 00 / Chassis units	32
Installation on the Wall - IP 21 (NEMA 1) and IP 54 (NEMA 12) Units	32
Floor Mounting - Pedestal Installation IP 21 (NEMA1) and IP 54 (NEMA12)	33
Gland/Conduit Entry - IP 21 (NEMA 1) and IP 54 (NEMA12)	35
IP 21 Drip shield installation (D1 and D2 enclosure)	36
Field Installation of Options	36
Installation on pedestal	46
Electrical Installation	49
Control Wires	49
Power Connections	50

Line connection	59
Fuses	60
Electrical Installation, Control Terminals	63
Connection Examples	65
Start/Stop	65
Pulse Start/Stop	65
Speed Up/Slow	66
Potentiometer Reference	66
Electrical Installation, Control Cables	67
Switches S201, S202, and S801	69
Final Set-Up and Test	70
Additional Connections	72
Mechanical Brake Control	72
Motor Thermal Protection	73
4. How to Program	75
The Graphical and Numerical LCP	75
How to Program on the Graphical LCP	75
How to Program on the Numerical Local Control Panel	76
Quick Setup	78
Parameter Lists	83
5. General Specifications	111
Product Specification:	117
6. Warnings and Alarms	127
Status Messages	127
Warnings/Alarm Messages	127
Index	136

1. How to Read the Instruction Manual

1

1.1. How to Read the Instruction Manual

1.1.1. How to Read this Instruction Manual

The adjustable frequency drive is designed to provide high shaft performance on electrical motors. Please read this manual carefully for proper use. Incorrect handling of the adjustable frequency drive may cause improper operation of the adjustable frequency drive or related equipment, shorten lifetime or cause other problems.

This Instruction Manual will help you get started as well as install, program, and troubleshoot your adjustable frequency drive.

Chapter 1, **How to Read this Instruction Manual**, introduces the manual and informs you about the approvals, symbols, and abbreviations used in this literature.

Chapter 2, **Safety Instructions and General Warnings**, contains instructions on how to handle the adjustable frequency drive correctly.

Chapter 3, **How to Install**, guides you through mechanical and technical installation.

Chapter 4, **How to Program**, shows you how to operate and program the adjustable frequency drive via the Local Control Panel.

Chapter 5, **General Specifications**, contains technical data about the adjustable frequency drive.

Chapter 6, **Warnings and Alarms**, assists you in solving problems that may occur when using the adjustable frequency drive.

Available Literature for the FC 300

- The VLT® Automation Drive FC 300 Instruction Manual provides the necessary information for getting the drive up and running.
- The VLT® Automation Drive FC 300 Design Guide contains all technical information about the drive design and applications including encoder, resolver and relay options.
- The VLT® Automation Drive FC 300 Profibus Instruction Manual provide the information required for controlling, monitoring and programming the drive via a Profibus serial communication bus.
- The VLT® Automation Drive FC 300 DeviceNet Instruction Manual provides the information required for controlling, monitoring and programming the drive via a DeviceNet serial communication bus.
- The VLT® Automation Drive FC 300 MCT 10 Instruction Manual provides information for installing and using the software on a PC.
- The VLT® Automation Drive FC 300 24 V DC Backup instructions provide information for installing the 24 V DC backup option.

Danfoss Drives technical literature is also available online at www.danfoss.com/drives.

1.1.2. Approvals



1.1.3. Symbols

Symbols used in this Instruction Manual.

**NOTE**

Indicates something to be noted by the reader.



Indicates a general warning.



Indicates a high-voltage warning.

*

Indicates a default setting

1.1.4. Abbreviations

Alternating current	AC
American wire gauge	AWG
Ampere/AMP	A
Automatic Motor Adaptation	AMA
Current limit	I _{LIM}
Degrees Celsius	°C
Direct current	DC
Drive Dependent	D-TYPE
Electro Magnetic Compatibility	EMC
Electronic Thermal Relay	ETR
drive	FC
Gram	g
Hertz	Hz
Kilohertz	kHz
Local Control Panel	LCP
Meter	m
Millihenry Inductance	mH
Milliampere	mA
Millisecond	ms
Minute	min
Motion Control Tool	MCT
Nanofarad	nF
Newton Meters	Nm
Nominal motor current	I _{M,N}
Nominal motor frequency	f _{M,N}
Nominal motor power	P _{M,N}
Nominal motor voltage	U _{M,N}
Parameter	par.
Protective Extra Low Voltage	PELV
Printed Circuit Board	PCB
Rated Inverter Output Current	I _{INV}
Revolutions Per Minute	RPM
Second	s
Torque limit	T _{LIM}
Volt	V



2. Safety Instructions and General Warning

2.1.1. Disposal Instructions



Equipment containing electrical components may not be disposed of together with domestic waste. It must be collected separately as electrical and electronic waste in accordance with local and currently valid legislation.



Caution

The adjustable frequency drive DC link capacitors remain charged after power has been disconnected. To avoid the electrical shock hazard, disconnect the adjustable frequency drive from the power supply before carrying out maintenance. Before servicing the adjustable frequency drive, wait the minimum amount of time indicated below:

380-500 V 125-300 hp [90-200 kW] 20 minutes

350-550 hp [250-400 kW] 40 minutes

525-690 V 50-350 hp [37-250 kW] 20 minutes

450-750 hp [315-560 kW] 30 minutes

FC 300
Instruction Manual
Software version: 4.5x



This Instruction Manual can be used for all FC 300 adjustable frequency drives with software version 4.5x.

The software version number can be found in parameter 15-43.

2.1.2. High Voltage



The voltage of the adjustable frequency drive is dangerous whenever the adjustable frequency drive is connected to line power. Incorrect installation or operation of the motor or adjustable frequency drive may cause damage to the equipment, serious personal injury or death. The instructions in this manual must therefore be observed, in addition to applicable local and national rules and safety regulations.



Installation at high altitudes

At altitudes higher than 6,500 ft [2 km], please contact Danfoss Drives regarding PELV.

2.1.3. Safety Instructions

- Make sure the adjustable frequency drive is properly grounded.
- Protect users against supply voltage.
- Protect the motor against overloading in accordance with national and local regulations.
- Motor overload protection is not included in the default settings. To add this function, set parameter 1-90 *Motor thermal protection* to value *ETR trip* or *ETR warning*. For the North American market: ETR functions provide class 20 motor overload protection, in accordance with NEC.
- The ground leakage current exceeds 3.5 mA.
- The [OFF] key is not a safety switch. It does not disconnect the adjustable frequency drive from line power.

2.1.4. General Warning



Warning:

Touching the electrical parts may be fatal - even after the equipment has been disconnected from line power.

Also make sure that other voltage inputs have been disconnected, such as load sharing (linkage of DC intermediate circuit), as well as the motor connection for kinetic backup.

When using the adjustable frequency drive: wait at least 40 minutes.

A shorter time is allowed only if indicated on the nameplate for the specific unit.



Leakage Current

The ground leakage current from the adjustable frequency drive exceeds 3.5 mA. To ensure that the ground cable has a good mechanical connection to the ground connection (terminal 95), the cable cross-section must be at least 0.016 in.² [10 mm²] or have 2 rated ground wires terminated separately.

Residual Current Device

This product can cause DC current in the protective conductor. If a residual current device (RCD) is used for extra protection, only an RCD of Type B (time delayed) may be used on the supply side of this product. See also RCD Application Note MN.90.Gx.02 (x=version number).

Protective grounding of the adjustable frequency drive and the use of RCDs must always follow national and local regulations.

2.1.5. Before Commencing Repair Work

1. Disconnect the adjustable frequency drive from the line power.
2. Wait for the discharge of the DC link. See the period of time on the warning label.
3. Disconnect DC bus terminals 88 and 89.
4. Remove motor cable.

2.1.6. Avoid Unintended Start

While the adjustable frequency drive is connected to line power, the motor can be started/stopped using digital commands, bus commands, references or via the Local Control Panel.

- Disconnect the adjustable frequency drive from line power whenever personal safety considerations make it necessary to avoid an unintended start.
- To avoid an unintended start, always activate the [OFF] key before changing parameters.
- An electronic fault, temporary overload, a fault in the line supply, or lost motor connection may cause a stopped motor to start. The adjustable frequency drive with safe stop provides protection against unintended start, if Safe Stop Terminal 37 is deactivated or disconnected.

2.1.7. Safe Stop

The FC 302 can perform the safety function *Safe Torque Off* (As defined by draft CD IEC 61800-5-2) or *Stop Category 0* (as defined in EN 60204-1).

It is designed and deemed suitable for the requirements of Safety Category 3 in EN 954-1. This function is called safe stop. Prior to integrating and using safe stop in an installation, a thorough risk analysis must be carried out on the installation in order to determine whether the safe stop functionality and safety category are appropriate and sufficient. In order to install and use the Safe Stop function in accordance with the requirements of Safety Category 3 in EN 954-1, the related information and instructions of the FC 300 Design Guide MG.33.BX.YY must be followed! The information and instructions contained in the Instruction Manual are not sufficient for a correct and safe use of the safe stop functionality!

Prüf- und Zertifizierungsstelle im BG-PRÜFZERT		 BGIA Berufsständeschaftliches Institut für Arbeitsschutz <small>Hauptverband der gewerblichen Berufsgenossenschaften</small>		130BA373.10
<small>Typenname, die Nummer originalen Stabnumm.</small> Titel Test Certificate		05 56004 <small>No. of certificate</small>		
<small>Name and address of the holder of the certificate (customer)</small>	Danfoss Drives A/S, Liljetoes 1 DK-6300 Groessten, Denmark			
<small>Name and address of the manufacturer</small>	Danfoss Drives A/S, Liljetoes 1 DK-6300 Groessten, Denmark			
<small>Ref. of customer</small>	<small>Ref. of Test and Certification Body ap/Nrh-16/AH, 2003 23220</small>	<small>Date of issue 13.04.2005</small>		
<small>Product designation</small>	Frequency converter with integrated safety functions			
<small>Type</small>	VLT® Automation Drive FC 302			
<small>Intended purpose</small>	Implementation of safety function „Safe Stop“			
<small>Testing based on:</small>	EN 954-1, 1997-03, DKE AK 226 03, 1998-06, EN ISO 13849-2, 2003-12, EN 61800-3, 2001-02, EN 61800-5-1, 2003-09.			
<small>Test certificate</small>	No.: 2003 23220 from 13.04.2005			
<small>Remarks:</small>	The presented types of the frequency converter FC 302 meet the requirements laid down in the test bases. With correct wiring a category 3 according to DIN EN 954-1 is reached for the safety function.			
<small>The type tested complies with the provisions laid down in the directive 98/37/EC (Machinery).</small>				
<small>Further conditions are laid down in the Rules of Procedure for Testing and Certification of April 2004.</small>				
<small>Head of certification body</small>	 <small>(Prof. Dr. rer. nat. Diether Rainald)</small>		<small>Certification officer</small> <small>(Dipl.-Ing. R. Apfel)</small>	
<small>PZB 108 #1 02</small>		<small>Field address: 33754 Sankt Augustin</small>	<small>Office: Alte Hasenelle 111 50737 Sankt Augustin</small>	<small>Phone: 0 22 41/2 31-00 Fax: 0 22 41/2 31-22 24</small>

2.1.8. Safe Stop Installation

To carry out an installation of a Category 0 Stop (EN60204) in conformity with Safety Category 3 (EN954-1), follow these instructions:

1. The bridge (jumper) between Terminal 37 and 24 V DC must be removed. Cutting or breaking the jumper is not sufficient. Remove it entirely to avoid short-circuiting. See jumper on illustration.
2. Connect terminal 37 to 24 V DC by a short circuit-protected cable. The 24 V DC voltage supply must be interruptible by an EN954-1 category 3 circuit interrupt device. If the interrupt device and the adjustable frequency drive are placed in the same installation panel, you can use an unshielded cable instead of a shielded one.



2.1: Bridge jumper between terminal 37 and 24 VDC

The illustration below shows a Stopping Category 0 (EN 60204-1) with safety Category 3 (EN 954-1). The circuit interruption is caused by an opening door contact. The illustration also shows how to connect a non-safety-related hardware coast.

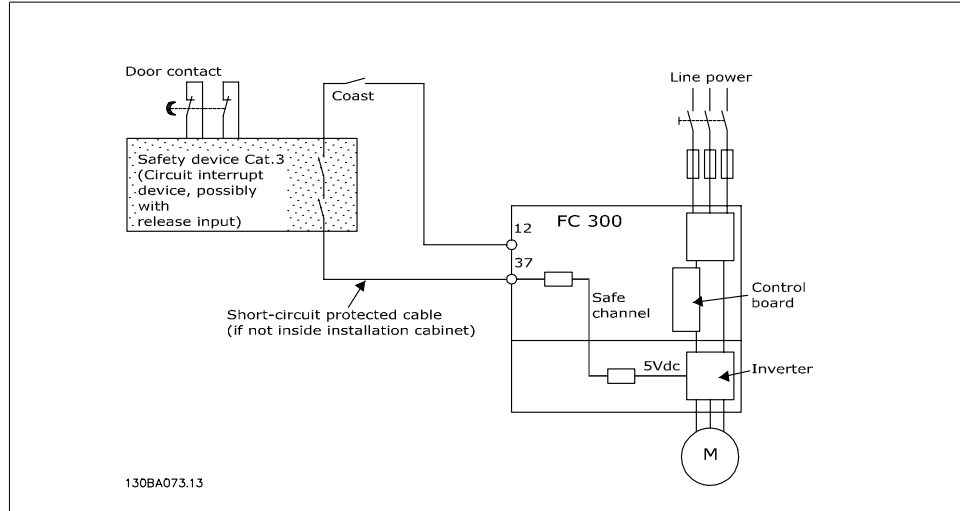

2.2: Illustration of the essential aspects of an installation to achieve a Stopping Category 0 (EN 60204-1) with safety Category 3 (EN 954-1).

2.1.9. IT Line

Par. 14-50 *RFI 1* can be used on the FC 102/202/302 to disconnect the internal RFI capacitors from the RFI filter to ground. If this is done, it will reduce the RFI performance to A2 level.



3

3. How to Install

3.1. How to Get Started

3.1.1. About How to Install

This chapter covers mechanical and electrical installations to and from power terminals and control card terminals.

Electrical installation of *options* is described in the relevant Instruction Manual and Design Guide.

3.1.2. How to Get Started

The adjustable frequency drive is designed for quick installation and is EMC-compliant. Just follow the steps described below.



Read the safety instructions before installing the unit.

Mechanical Installation

- Mechanical mounting

Electrical Installation

- Connection to Line and Protecting Ground
- Motor connection and cables
- Fuses and circuit breakers
- Control terminals - cables

Quick set-up

- Local Control Panel, LCP
- Automatic Motor Adaptation, AMA
- Programming

Frame size is dependent on enclosure type, power range and line voltage.

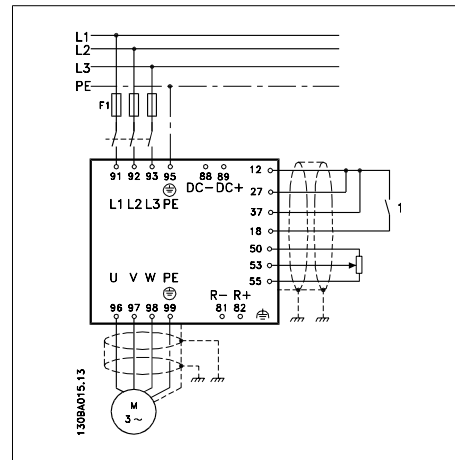

3.1: Diagram showing basic installation including line power, motor, start/stop key, and potentiometer for speed adjustment.

3.2. Pre-installation

3.2.1. Planning the Installation Site

**NOTE**

Before performing the installation, it is important to plan the installation of the adjustable frequency drive. Neglecting this may result in extra work during and after installation.

Select the best possible operation site by considering the following (see details on the following pages and in the respective Design Guides):

- Ambient operating temperature
- Installation method
- How to cool the unit
- Position of the adjustable frequency drive.
- Cable routing
- Ensure the power source supplies the correct voltage and necessary current.
- Ensure that the motor current rating is within the maximum current from the adjustable frequency drive.
- If the adjustable frequency drive is without built-in fuses, ensure that the external fuses are rated correctly.

3.2.2. Receiving the Adjustable Frequency Drive

When receiving the adjustable frequency drive, make sure that the packaging is intact, and look for any damage that might have occurred to the unit during transport. If damage has occurred, immediately contact the shipping company to make a damage claim.

3.2.3. Transportation and Unpacking

Before unpacking the adjustable frequency drive, it is recommended to unload it as close as possible to the final installation site.

Remove the cardboard box and keep the adjustable frequency drive on the pallet as long as possible. Remark: The cardboard box cover contains a drilling master for the mounting holes.

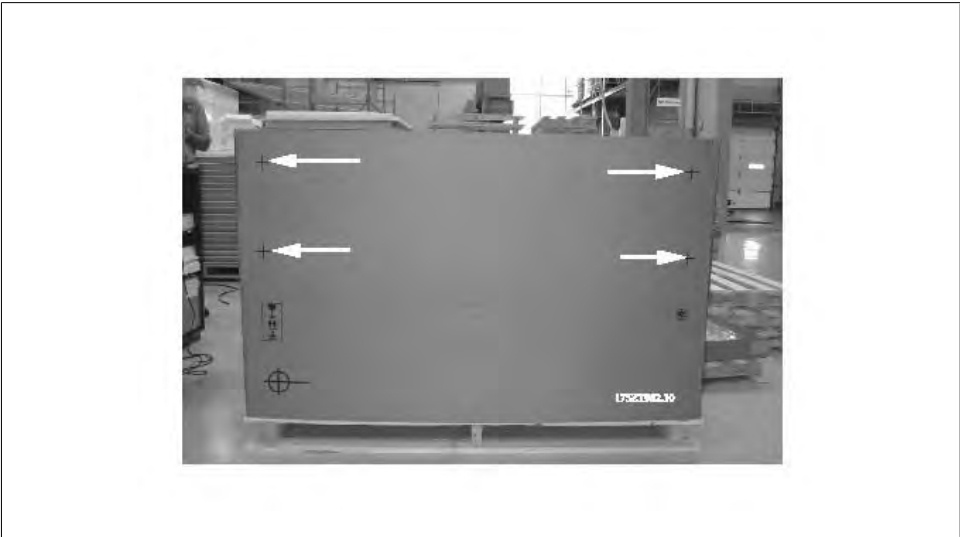

3.2: Mounting Template

3.2.4. Lifting

Always lift the adjustable frequency drive using the dedicated lifting holes. Use a bar to avoid bending the lifting holes of the adjustable frequency drive.

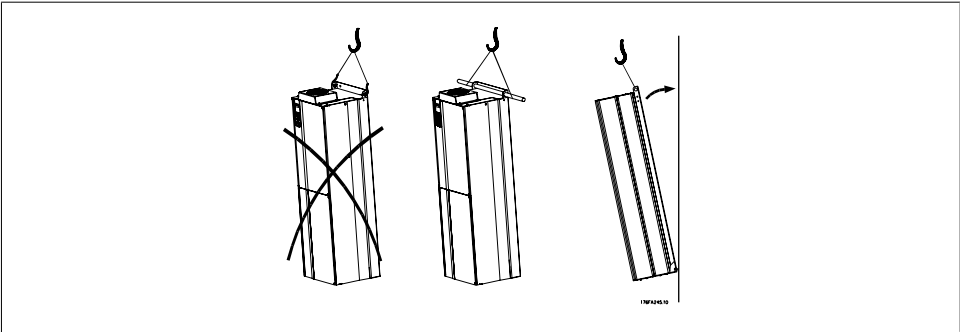

3.3: Recommended lifting method

3.2.5. Mechanical Dimensions

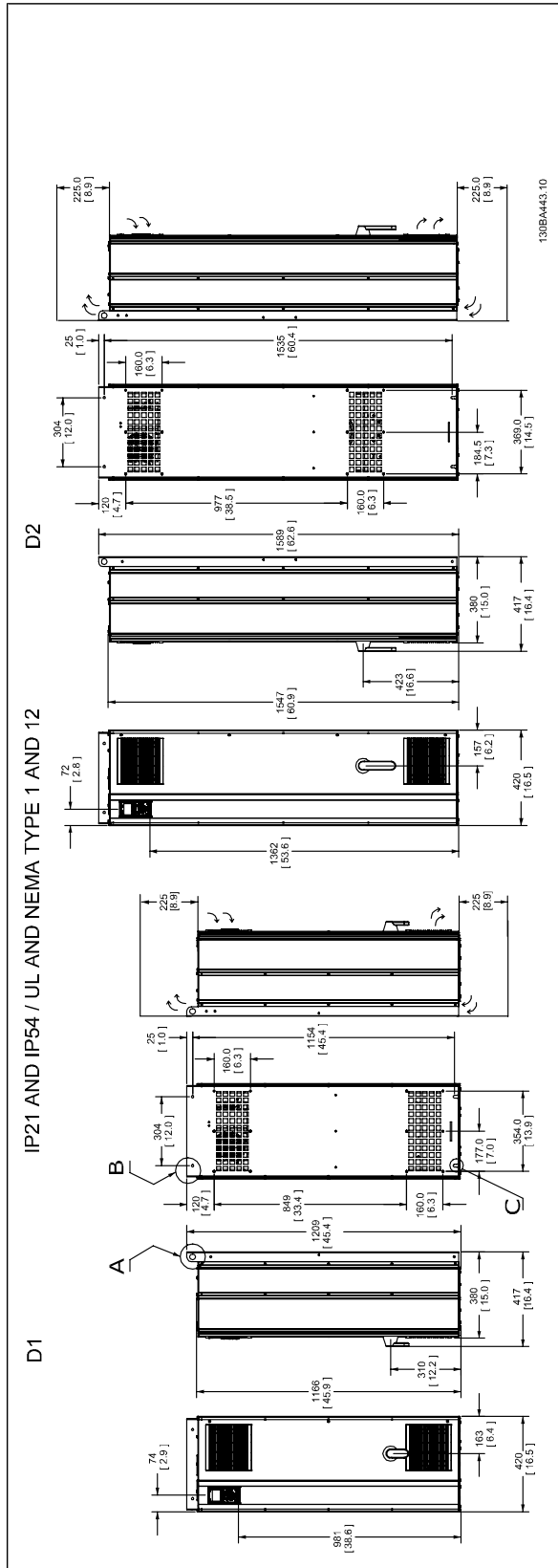

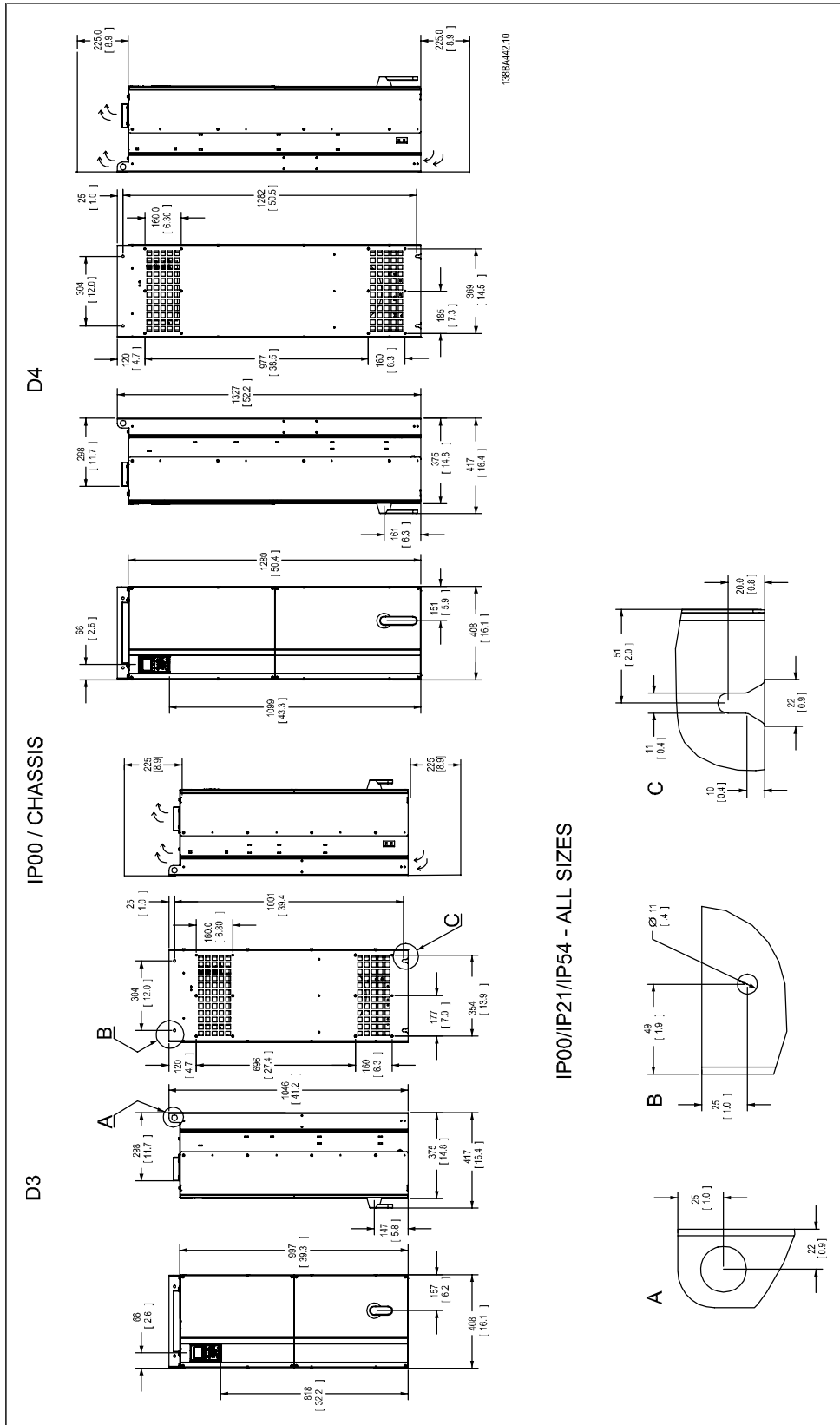

3

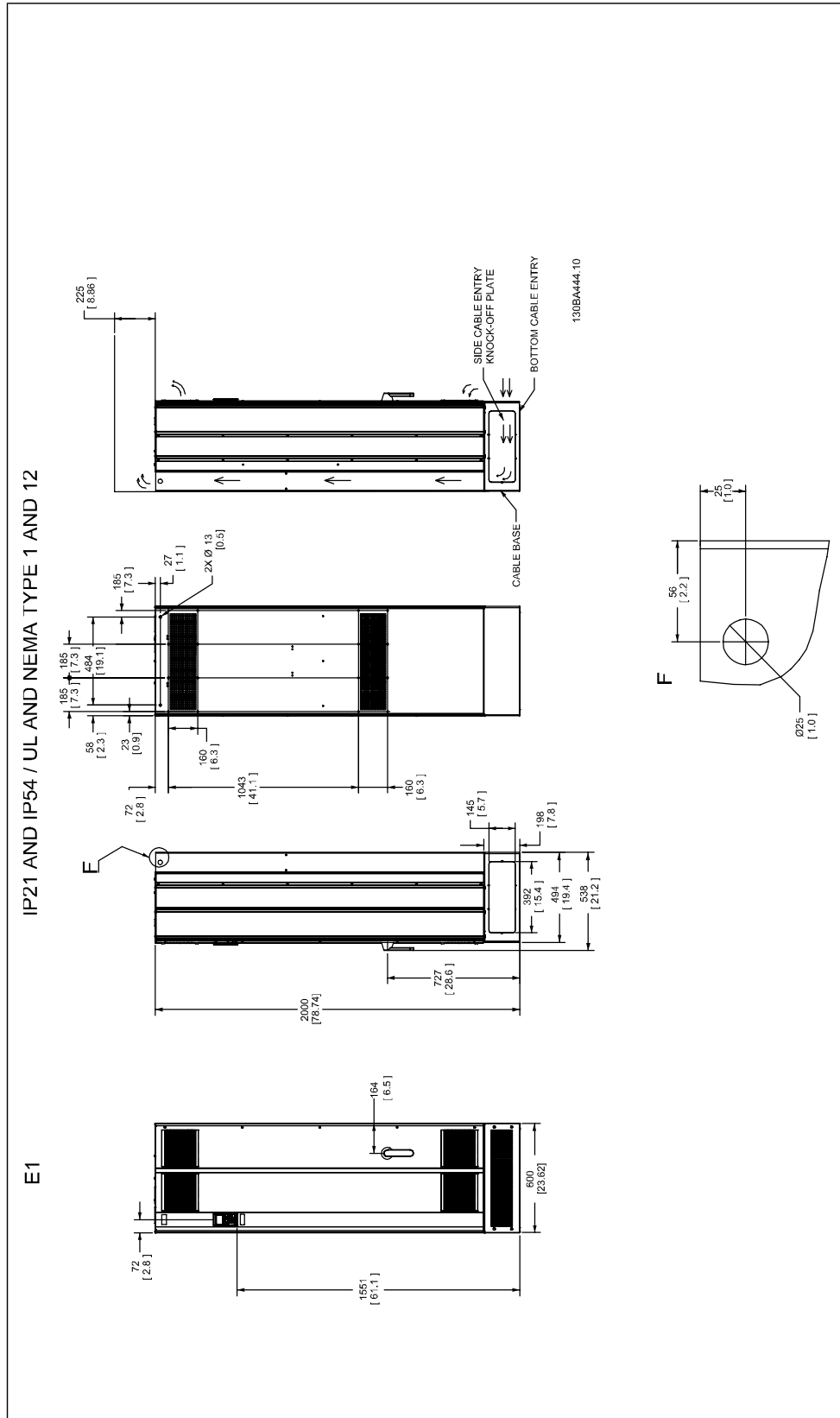

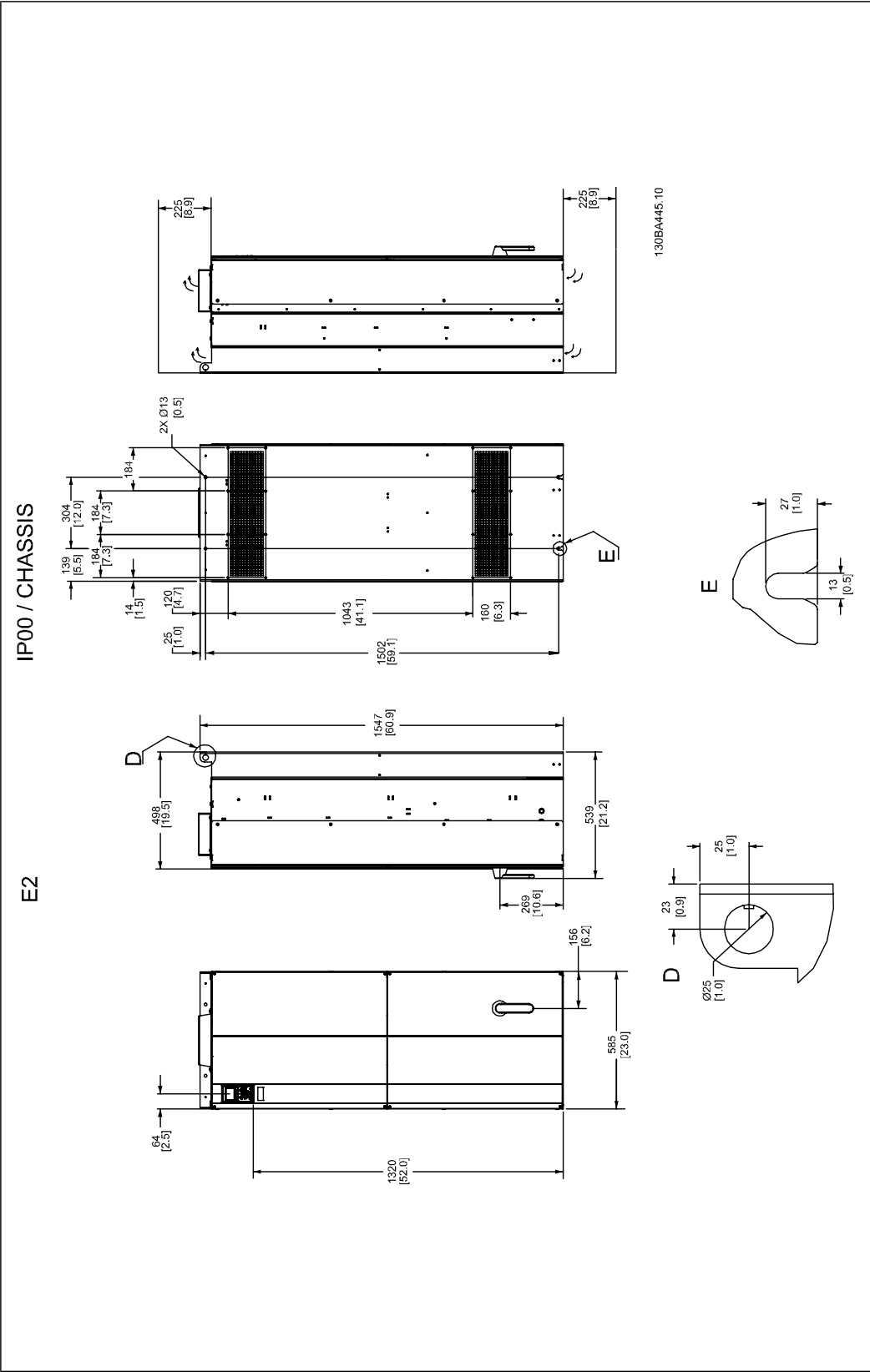



Mechanical dimensions, D Enclosures							
Frame size		D1		D2		D3	D4
		125-150 hp [90-110 kW] (380-500 V) 150-175 hp [110-132 kW] (525-690 V)		175-300 hp [132-200 kW] (380-500 V) 250-450 hp [160-315 kW] (525-690 V)		125-150 hp [90-110 kW] (380-500 V) 150-175 hp [110-132 kW] (525-690 V)	175-300 hp [132-200 kW] (380-500 V) 250-450 hp [160-315 kW] (525-690 V)
IP NEMA		21 Type 1	54 Type 12	21 Type 1	54 Type 12	00 Chassis	00 Chassis
Cardboard box size Shipping dimensions	Height	25.6 in [650 mm]	25.6 in [650 mm]	25.6 in [650 mm]	25.6 in [650 mm]	25.6 in [650 mm]	25.6 in [650 mm]
	Width	68.1 in [1730 mm]	68.1 in [1730 mm]	68.1 in [1730 mm]	68.1 in [1730 mm]	48 in [1220 mm]	58.7 in [1490 mm]
	Depth	22.4 in [570 mm]	22.4 in [570 mm]	22.4 in [570 mm]	22.4 in [570 mm]	22.4 in [570 mm]	22.4 in [570 mm]
Drive dimensions	Height	45.6 in [1159 mm]	45.6 in [1159 mm]	60.6 in [1540 mm]	60.6 in [1540 mm]	39.3 in [997 mm]	50.3 in [1277 mm]
	Width	16.5 in [420 mm]	16.5 in [420 mm]	16.5 in [420 mm]	16.5 in [420 mm]	16.1 in [408 mm]	16.1 in [408 mm]
	Depth	14.7 in [373 mm]	14.7 in [373 mm]	14.7 in [373 mm]	14.7 in [373 mm]	14.7 in [373 mm]	14.7 in [373 mm]
	Max weight	229.3 lbs [104 kg]	229.3 lbs [104 kg]	332.9 lbs [151 kg]	332.9 lbs [151 kg]	200.6 lbs [91 kg]	304.2 lbs [138 kg]

Mechanical dimensions, E Enclosures				
Frame size		E1		E2
		350-550 hp [250-400 kW] (380-500 V) 500-750 hp [355-560 kW] (525-690 V)		350-550 hp [250-400 kW] (380-500 V) 500-750 hp [355-560 kW] (525-690 V)
IP NEMA		21 Type 12		54 Type 12
				00 Chassis
Cardboard box size Shipping dimensions	Height	33.1 in [840 mm]		32.7 in [831 mm]
	Width	86.5 in [2197 mm]		67.1 in [1705 mm]
	Depth	29 in [736 mm]		29 in [736 mm]
Drive dimensions	Height	78.7 in [2000 mm]		59 in [1499 mm]
	Width	23.6 in [600 mm]		23 in [585 mm]
	Depth	19.5 in [494 mm]		19.5 in [494 mm]
	Max weight	690 lbs [313 kg]		611 lbs [277 kg]

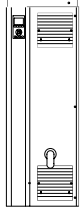
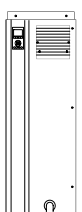
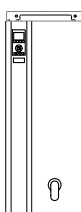
3.2.6. Rated Power

Enclosure type		D1	D2	D3	D4
		 130BA481.10	 130BA482.10	 130BA478.10	 130BA479.10
Enclosure protection	IP	21/54	21/54	00	00
	NEMA	Type 1/ Type 12	Type 1/ Type 12	Chassis	Chassis
Rated power		125-150 hp [90-110 kW] at 400 V (380-500 V) 150-200 hp [110-132 kW] at 690 V (525-690 V)	200-300 hp [132-200 kW] at 400 V (380-500 V) 250-450 hp [160-315 kW] at 690 V (525-690 V)	125-150 hp [90-110 kW] at 400 V (380-500 V) 150-200 hp [110-132 kW] at 690 V (525-690 V)	200-300 hp [132-200 kW] at 400 V (380-500 V) 250-450 hp [160-315 kW] at 690 V (525-690 V)

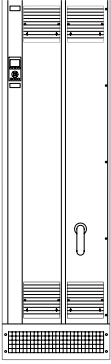
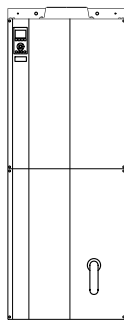
Enclosure type		E1	E2
		 130BA483.10	 130BA480.10
Enclosure protection	IP	21/54	00
	NEMA	Type 1/ Type 12	Chassis
Rated power		350-550 hp [250-400 kW] at 400 V (380-500 V) 500-750 hp [355-560 kW] at 690 V (525-690 V)	320-550 hp [240-400 kW] at 400 V (380-500 V) 500-750 hp [355-560 kW] at 690 V (525-690 V)

3.3. Mechanical Installation

Preparation of the mechanical installation of the adjustable frequency drive must be done carefully to ensure proper results and to avoid additional work during installation. Start by taking a close look at the mechanical drawings at the end of this instruction manual to become familiar with the space demands.

3.3.1. Tools Needed

To perform the mechanical installation, the following tools are needed:

- Drill with 0.39 or 0.47 in [10 or 12 mm] drill.
- Tape measure
- Wrench with relevant metric sockets (7-17 mm)
- Extensions to wrench
- Sheet metal punch for conduits or cable glands in IP 21 and IP 54 units
- Lifting bar to lift the unit (rod or tube \varnothing 0.75 in [20 mm]) able to lift minimum 880 lbs [400 kg].
- Crane or other lifting aid to place the adjustable frequency drive in position
- A Torx T50 tool is needed to install the E1 enclosure in IP 21 and IP 54 enclosure types.

3.3.2. General Considerations

Space

Ensure proper clearance space above and below the adjustable frequency drive to allow airflow and cable access. In addition, space in front of the unit must be considered to enable opening the door of the panel.

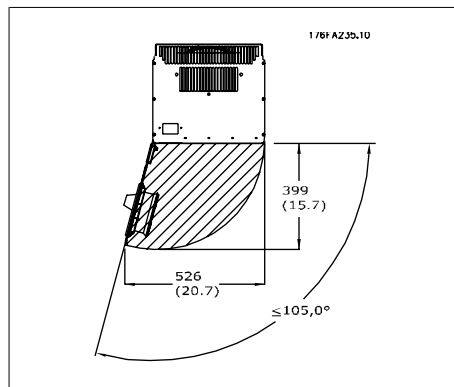

3.4: Space in front of IP 21/IP 54 enclosure type D1 and D2.

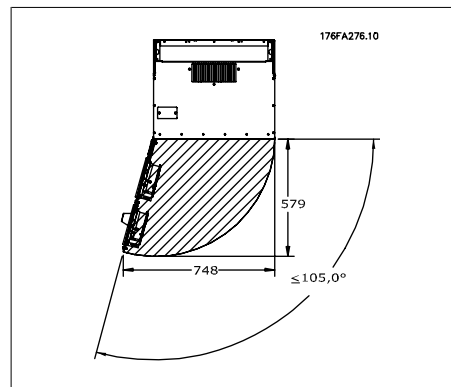

3.5: Space in front of IP 21/IP 54 enclosure type E1.

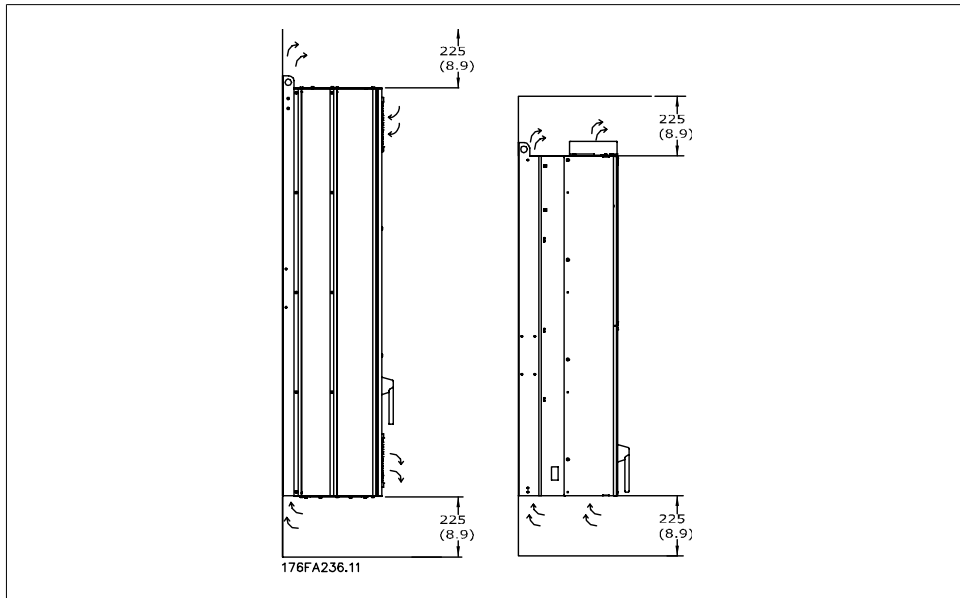

3.6: Airflow direction and necessary space for cooling
 Left: Enclosure IP 21/IP 54, D1 and D2.
 Right: Enclosure IP 00, D3, D4 and E2.

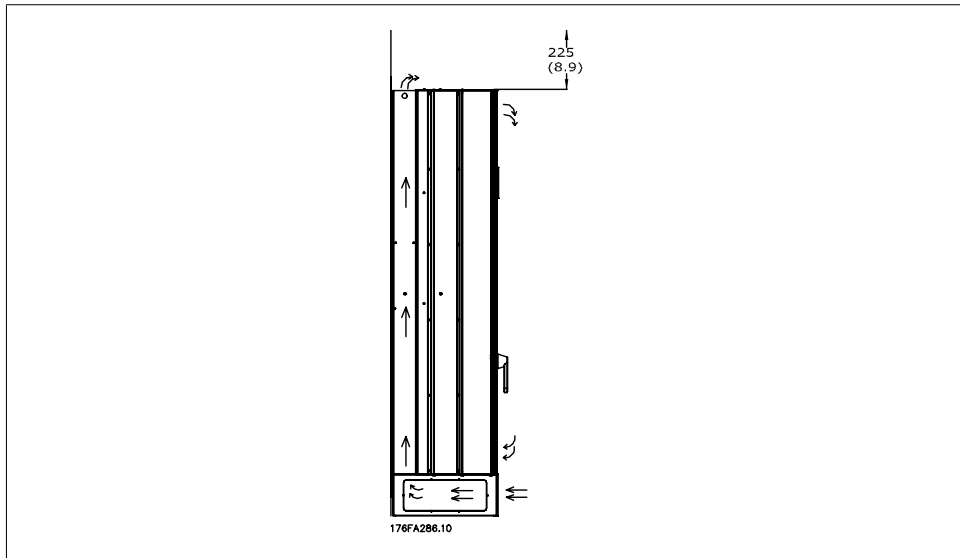

3.7: Airflow direction and necessary space for cooling - Enclosure IP 21/IP 54, E1

Wire access

Ensure that proper cable access is present including the necessary bending allowance. Since the IP 00 enclosure is open, the bottom cables must be attached to the back panel of the enclosure where the adjustable frequency drive is mounted, i.e., by using cable clamps.

3

**Terminal locations
(D1 and D2 enclosures)**

Take the following terminal positions into consideration when you design for cable access.

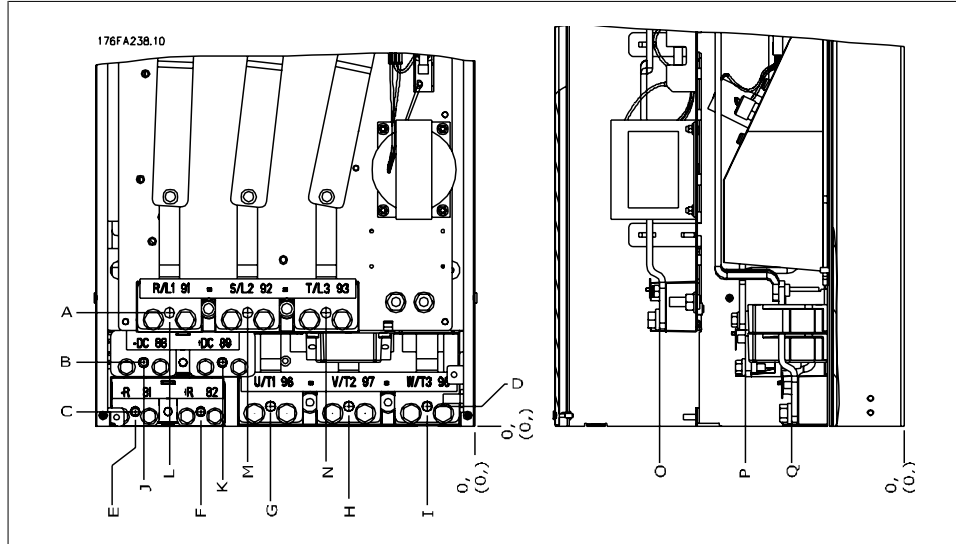

3.8: Position of power connections

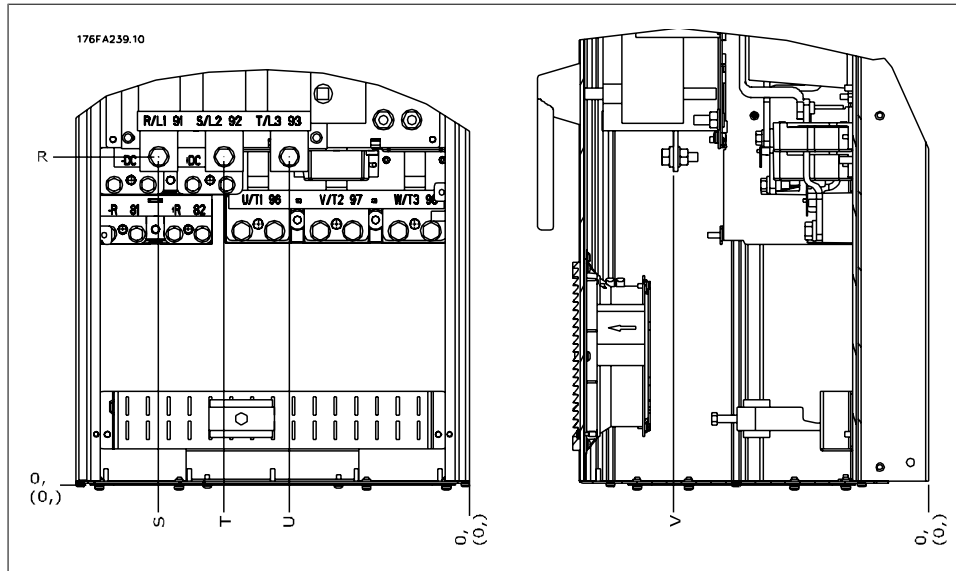

3.9: Position of power connections - Disconnect

Be aware that the power cables are heavy and hard to bend. Give thought to the optimum position of the adjustable frequency drive for ensuring easy installation of the cables.

	IP 21 (NEMA 1) / IP 54 (NEMA 12)		IP 00 / Chassis	
	Enclosure D1	Enclosure D2	Enclosure D3	Enclosure D4
A	277 (10.9)	379 (14.9)	119 (4.7)	122 (4.8)
B	227 (8.9)	326 (12.8)	68 (2.7)	68 (2.7)
C	173 (6.8)	273 (10.8)	15 (0.6)	16 (0.6)
D	179 (7.0)	279 (11.0)	20.7 (0.8)	22 (0.8)
E	370 (14.6)	370 (14.6)	363 (14.3)	363 (14.3)
F	300 (11.8)	300 (11.8)	293 (11.5)	293 (11.5)
G	222 (8.7)	226 (8.9)	215 (8.4)	218 (8.6)
H	139 (5.4)	142 (5.6)	131 (5.2)	135 (5.3)
I	55 (2.2)	59 (2.3)	48 (1.9)	51 (2.0)
J	354 (13.9)	361 (14.2)	347 (13.6)	354 (13.9)
K	284 (11.2)	277 (10.9)	277 (10.9)	270 (10.6)
L	334 (13.1)	334 (13.1)	326 (12.8)	326 (12.8)
M	250 (9.8)	250 (9.8)	243 (9.6)	243 (9.6)
N	167 (6.6)	167 (6.6)	159 (6.3)	159 (6.3)
O	261 (10.3)	260 (10.3)	261 (10.3)	261 (10.3)
P	170 (6.7)	169 (6.7)	170 (6.7)	170 (6.7)
Q	120 (4.7)	120 (4.7)	120 (4.7)	120 (4.7)
R	256 (10.1)	350 (13.8)	98 (3.8)	93 (3.7)
S	308 (12.1)	332 (13.0)	301 (11.8)	324 (12.8)
T	252 (9.9)	262 (10.3)	245 (9.6)	255 (10.0)
U	196 (7.7)	192 (7.6)	189 (7.4)	185 (7.3)
V	260 (10.2)	273 (10.7)	260 (10.2)	273 (10.7)

3.1: Cable positions as shown in the drawings above. Dimensions in inches [mm].

3

Terminal locations - E1 enclosures

Give thought to the following terminal positions when designing the cable access.

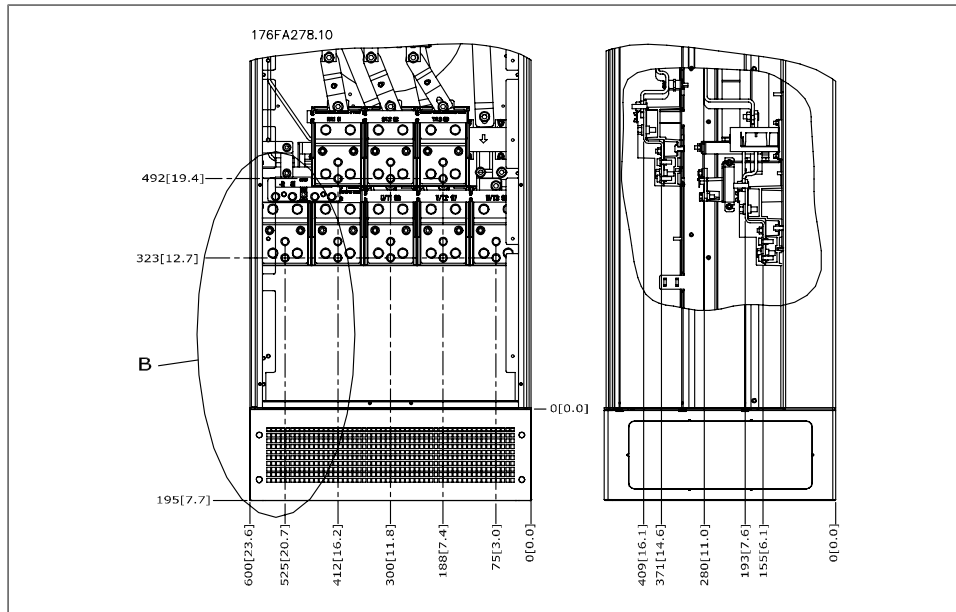

3.10: IP 21 (NEMA Type 1) and IP 54 (NEMA Type 12) enclosure power connection positions

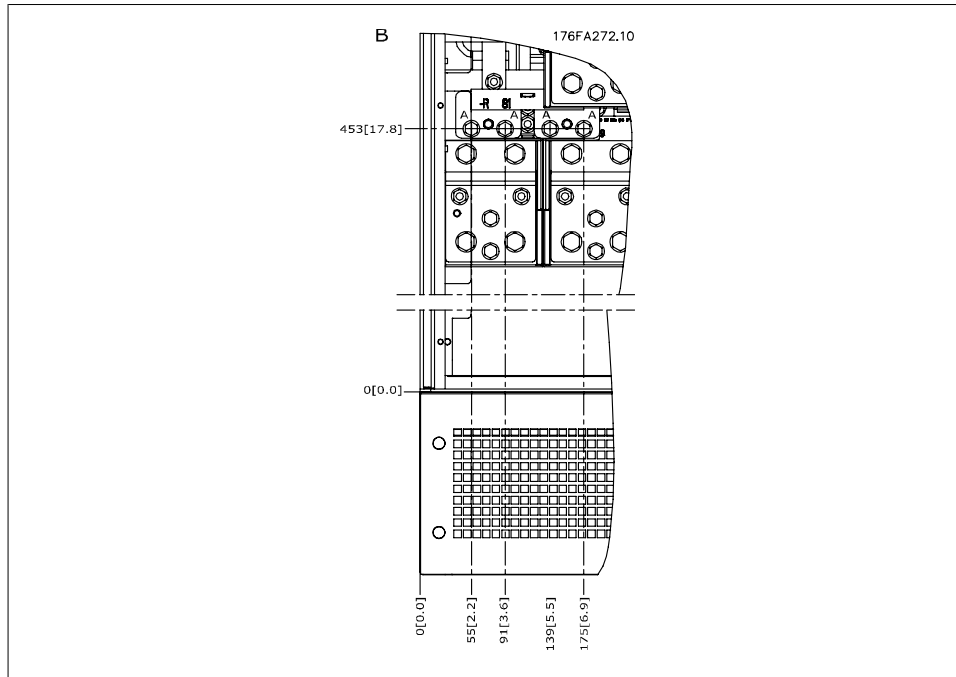

3.11: IP 21 (NEMA type 1) and IP 54 (NEMA type 12) enclosure power connection positions (detail B)

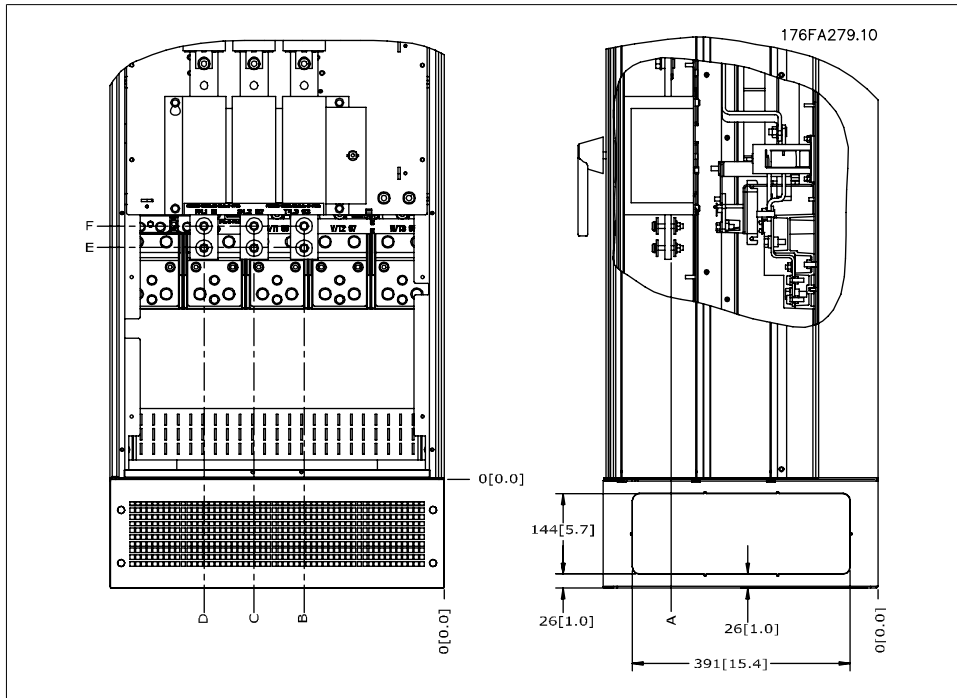

3.12: IP 21 (NEMA type 1) and IP 54 (NEMA type 12) enclosure power connection position of disconnect switch

Terminal locations - E2 enclosures

Give thought to the following terminal positions when designing the cable access.

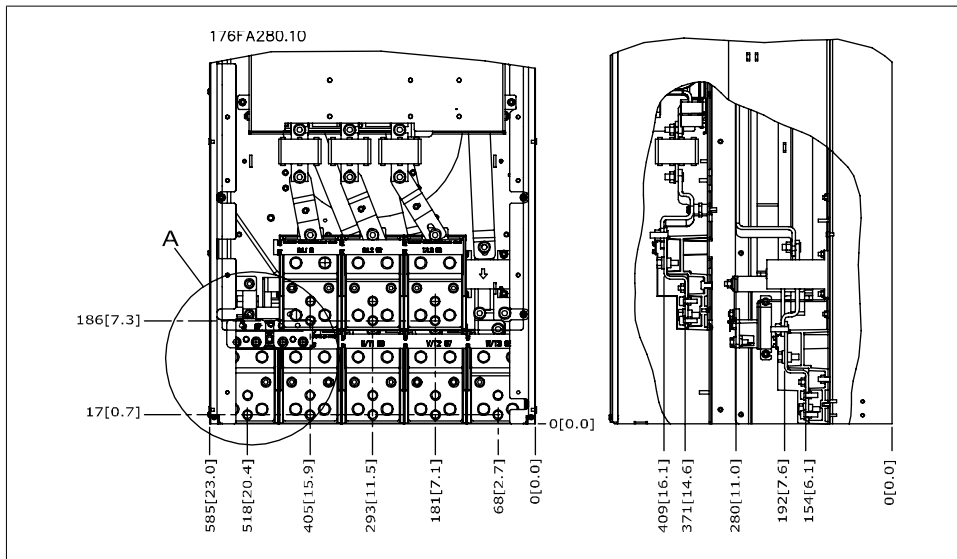

3.13: IP 00 enclosure power connection positions

3

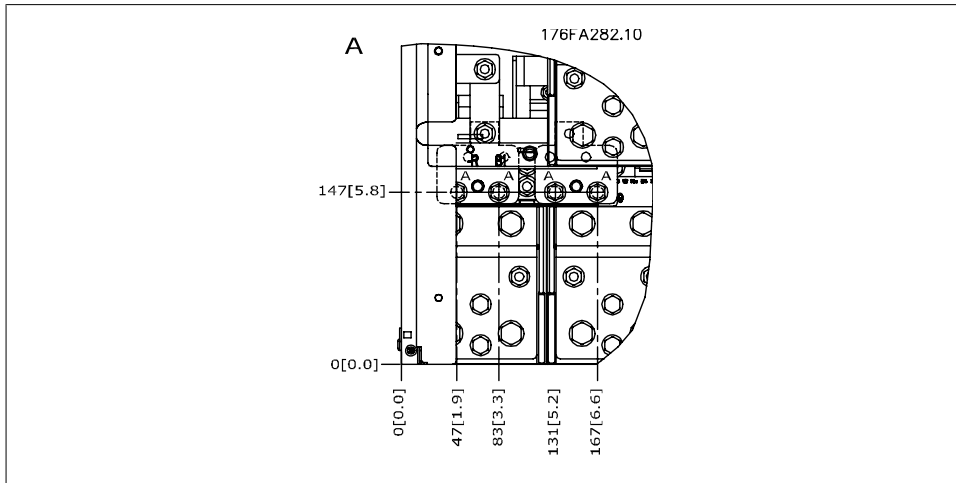

3.14: IP 00 enclosure power connection positions

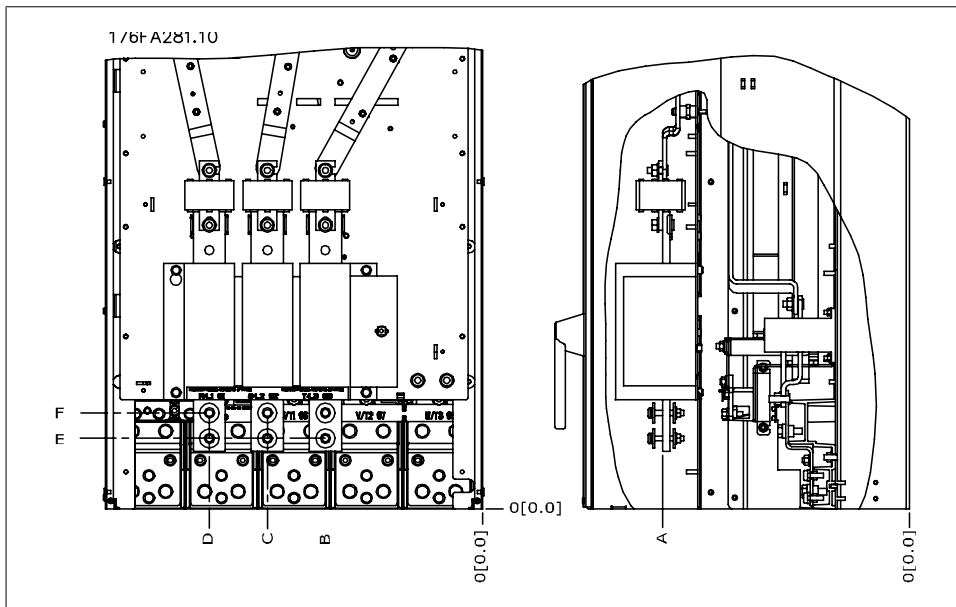

3.15: IP 00 enclosure power connections positions of disconnect switch

Note that the power cables are heavy and difficult to bend. Give thought to the optimum position of the adjustable frequency drive for ensuring easy installation of the cables. Each terminal allows for the use of up to 4 cables with cable lugs or the use of standard box lug. Ground is connected to relevant termination point in the drive.

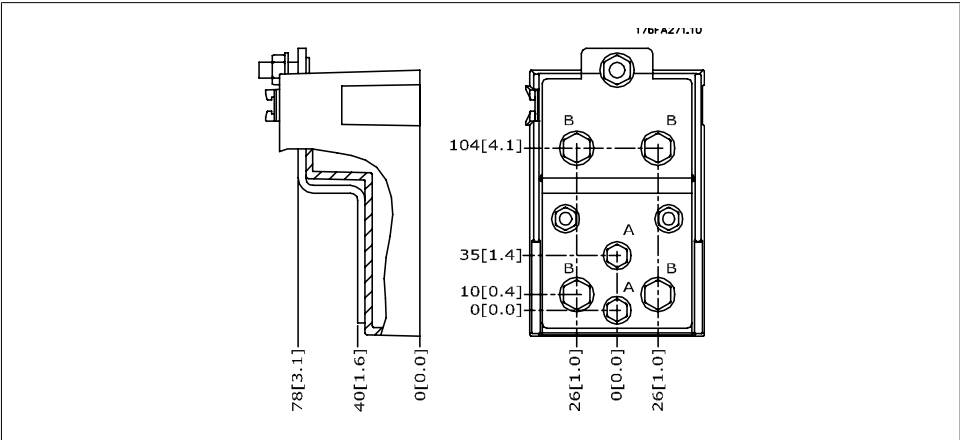

3.16: Terminal in details

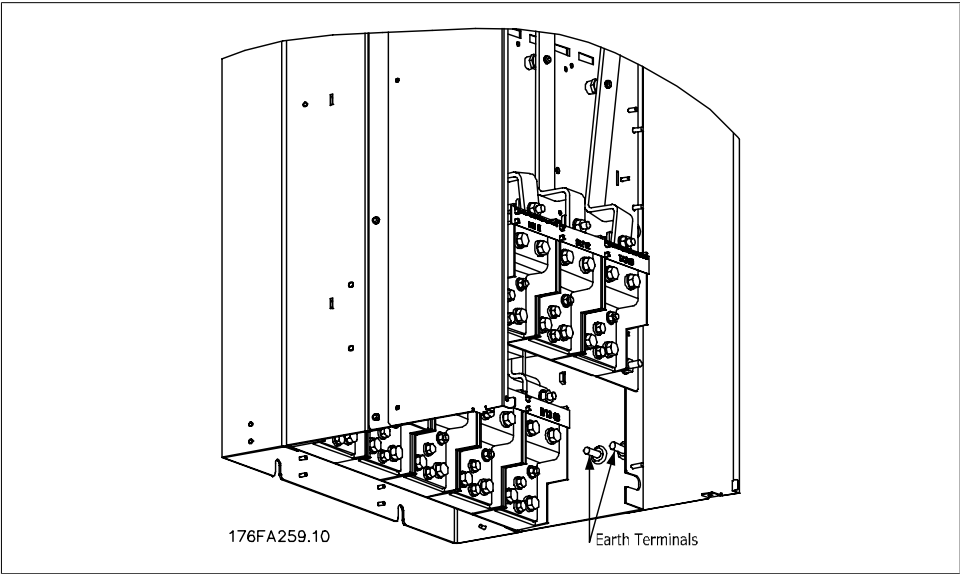

3.17: Position of ground terminals IP 00

3

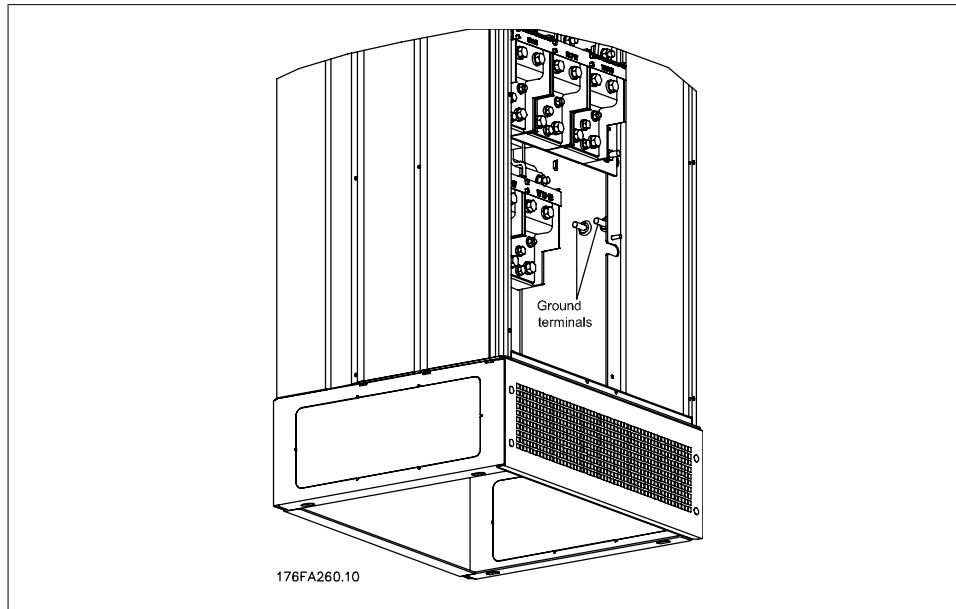

3.18: Position of ground terminals IP 21 (NEMA type 1) and IP 54 (NEMA type 12)

Cooling

Cooling can be performed in different ways: by using the cooling ducts in the bottom and the top of the unit, by using the ducts in the rear of the unit or by combining cooling options.

Airflow

The necessary airflow over the heatsink must be ensured. The flow rate is shown below.

Enclosure		Door fan/Top fan airflow	Airflow over heat-sink
IP 21 / NEMA 1 & IP 54 / NEMA 12	D1 and D2	6,003 ft ³ /h [170 m ³ /h] (100 cfm)	27,015 ft ³ /h [765 m ³ / h] (450 cfm)
	E1	12,006 ft ³ /h [340 m ³ / h] (200 cfm)	50994 ft ³ /h [1444 m ³ / h] (850 cfm)
IP 00 / Chassis	D3 and D4	9,005 ft ³ /h [255 m ³ /h] (150 cfm)	27,015 ft ³ /h [765 m ³ / h] (450 cfm)
	E2	9,005 ft ³ /h [255 m ³ /h] (150 cfm)	50994 ft ³ /h [1444 m ³ / h] (850 cfm)

3.2: Heatsink Air Flow

Duct cooling

A dedicated option has been developed to optimize installation of IP00 / Chassis enclosed adjustable frequency drives in Rittal TS8 enclosures utilizing the fan of the adjustable frequency drive for forced cooling.

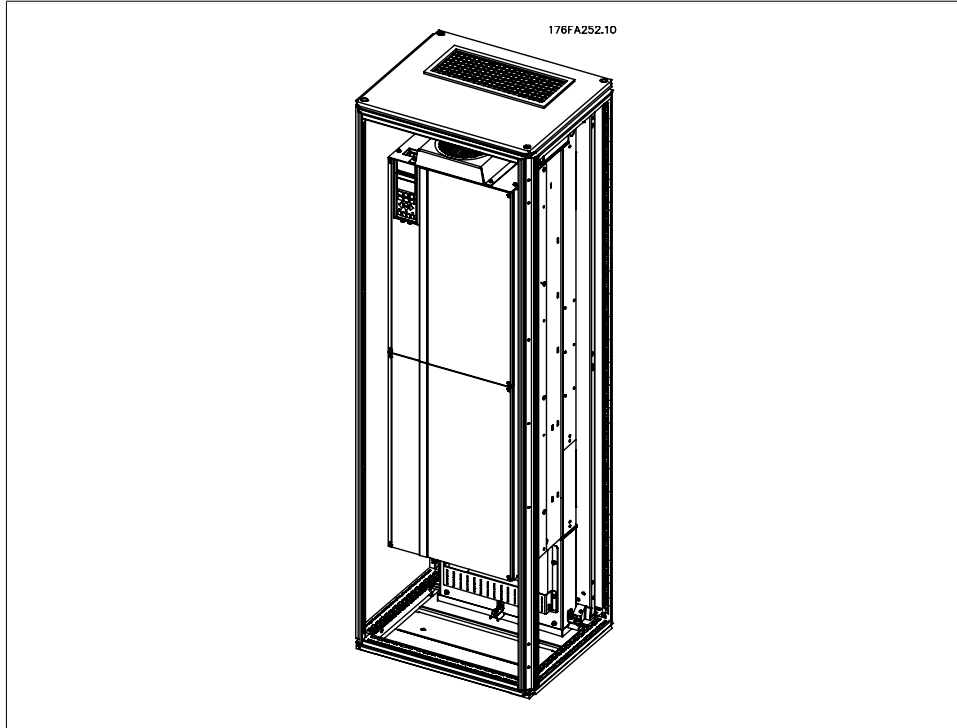

3.19: Installation of IP 00 in Rittal TS8 enclosure

Rittal TS8 Enclosure	Frame D3 Kit Part No.	Frame D4 Kit Part No.	Frame E2 Part No.
70.9 in [1800 mm]	176F1824	176F1823	Not possible
78.7 in [2000 mm]	176F1826	176F1825	176F1850
86.6 in [2200 mm]			176F0299

3.3: Duct Kit Ordering Numbers

Back cooling

Using the channel from the back allows for easy installation in control rooms, for example. The unit mounted at the rear of the enclosure allows for the cooling of the units just as easily as the duct cooling principle. The hot air is ventilated out of the back of the enclosure. This offers a solution in which the hot cooling air from the adjustable frequency drive does not cause the control room to heat up.

NOTE
 A small door fan is required on the Rittal cabinet to provide additional cooling within the drive.



3.20: Combined use of cooling principles

The above mentioned solution can of course also be combined for an optimized solution in the actual installation.

Please see the Duct Kit Instruction Manual, 175R5640, for further information.

3.3.3. Installation in Enclosures - IP 00 / Chassis units

Since the IP 00 version is intended for panel mounting, it is important to know how to install the adjustable frequency drive and use the options available for cooling the units. A detailed description of how to install the adjustable frequency drive in a Rittal TS8 enclosure using the installation kit can be found in a later section of this Installation Guide. This can also be used as a guide for other installations.

3.3.4. Installation on the Wall - IP 21 (NEMA 1) and IP 54 (NEMA 12) Units

This only applies for D1 and D2 enclosures.

Thought must be given to where the unit should be installed.

Take the relevant points into consideration before you select the final installation site:

- Clearance space for cooling
- Clearance for opening the door
- Cable entry clearance from the bottom

Mark the mounting holes carefully using the mounting template on the wall, and drill the holes as indicated. Ensure proper distance to the floor and the ceiling for cooling. A minimum of 8.9 in [225 mm] below the adjustable frequency drive is needed. Mount the bolts at the bottom and lift the adjustable frequency drive up on the bolts. Tilt the adjustable frequency drive against the wall and mount the upper bolts. Tighten all four bolts to secure the adjustable frequency drive against the wall.

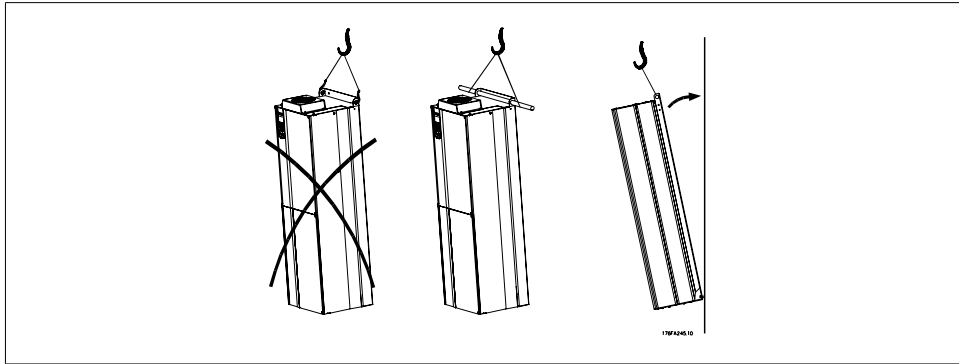

3.21: Lifting method for mounting drive on wall

3.3.5. Floor Mounting - Pedestal Installation IP 21 (NEMA1) and IP 54 (NEMA12)

IP 21 (NEMA type 1) and IP 54 (NEMA type 12) enclosed adjustable frequency drives can also be installed on a pedestal.

D1 and D2 enclosures

Ordering No. 176F1827

Please see the Pedestal Kit Instruction Manual, 175R5642, for further information.



3.22: Drive on pedestal

3

The E1 enclosure is always delivered with a pedestal as standard. Install the pedestal on the floor. Fixing holes are to be drilled according to this figure:

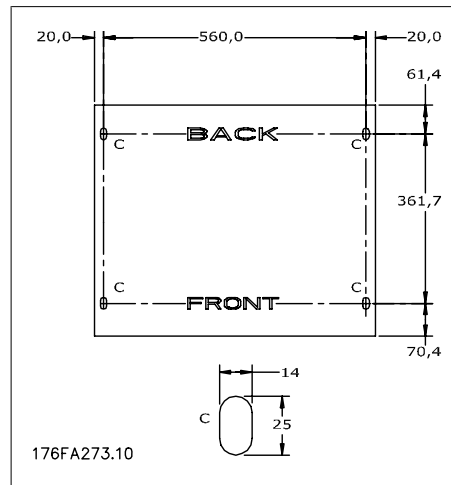

3.23: Drill master for fixing holes in floor.

Mount the drive on the pedestal and using the enclosed bolts, attach it to the pedestal, as shown in the illustration.

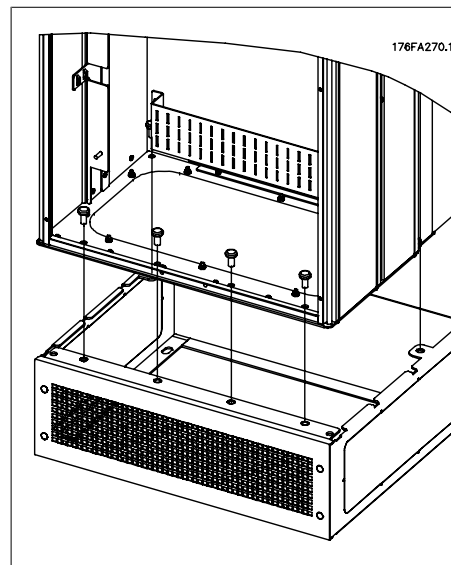

3.24: Mounting the drive to the pedestal

3.3.6. Gland/Conduit Entry - IP 21 (NEMA 1) and IP 54 (NEMA12)

Cables are connected through the gland plate from the bottom. Remove the plate and plan where to place the entry for the glands or conduits. Prepare holes in the marked area on the drawing.

The gland plate must be fitted to the adjustable frequency drive to ensure the specified protection degree, as well as ensuring proper cooling of the unit. If the gland plate is not mounted, it may trip the unit.

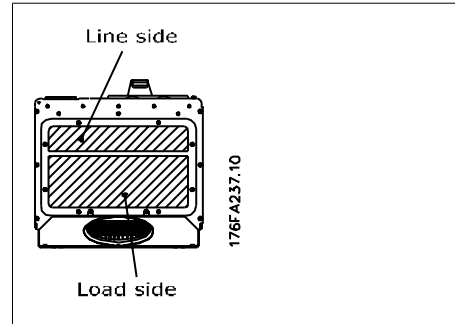

3.25: Cable entry viewed from the bottom of the adjustable frequency drive - Enclosure D1 and D2.

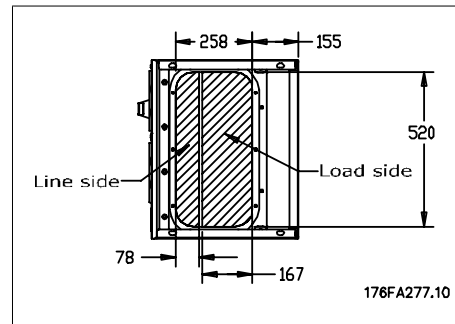

3.26: Cable entry seen from the bottom of the adjustable frequency drive - Enclosure E1.

The bottom plate of the E1 enclosure can be mounted from either in or outside of the enclosure, allowing flexibility in the installation process, i.e., if mounted from the bottom, the glands and cables can be mounted before the adjustable frequency drive is placed on the pedestal.

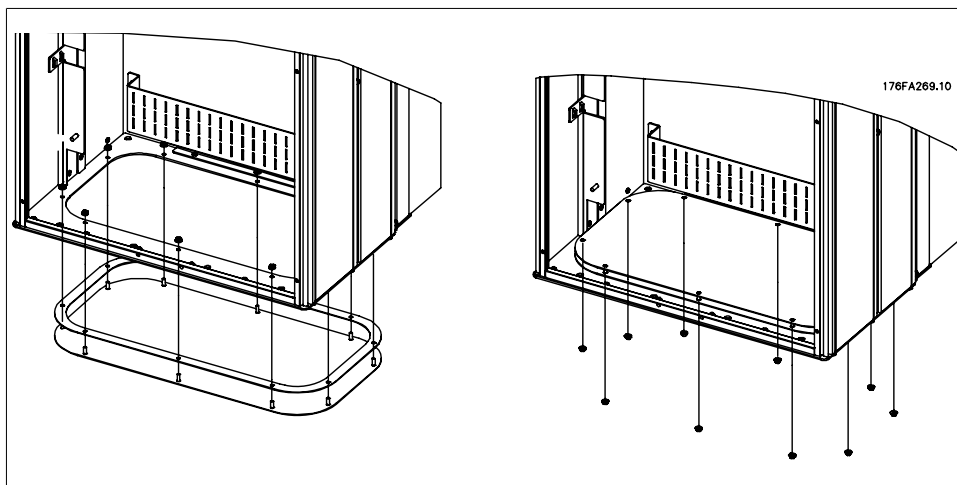

3.27: Mounting of bottom plate, E1 enclosure.

3.3.7. IP 21 Drip shield installation (D1 and D2 enclosure)

To comply with the IP 21 rating, a separate drip shield is to be installed as explained below:

- Remove the two front screws.
- Insert the drip shield and replace the screws.
- Torque the screws to 5.6 Nm (50 in-lbs).

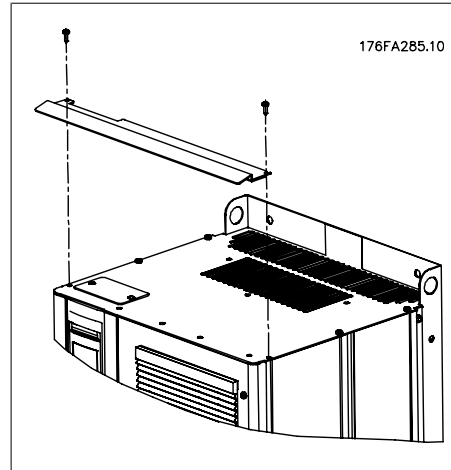

3.28: Install the drip shield.

3.4. Field Installation of Options

This chapter deals with the installation of IP 00/chassis-enclosed adjustable frequency drives with duct work cooling kits in Rittal enclosures. These kits are designed and tested to be used with Rittal TS8 enclosures 71 in [1,800 mm] (Frame D1 and D2 only) and 79 in [2,000 mm] height, as well as 87 in [2,200 mm] for E2 enclosures. Other enclosure heights are not supported. In addition to the enclosure, an 8 in [200 mm] base/plinth is required.

The minimum enclosure dimension is:

- D1 and D2 frame: Depth 19.7 in [500 mm] and width 23.6 in [600 mm].
- E1 frame: Depth 23.6 in [600 mm] and width 31.5 in [800 mm].

The maximum depth and width are as required for the installation. When using multiple adjustable frequency drives in one enclosure, it is recommended that each drive be mounted on its own back panel and supported along the mid-section of the panel. These duct work kits do not support the "in frame" mounting of the panel (see Rittal TS8 catalog for details). The duct work cooling kits listed in the table below are suitable for use only with IP 00/chassis adjustable frequency drives in Rittal TS8 IP 20 and UL and NEMA 1 and IP 54 and UL and NEMA 12 enclosures.

The duct work shown is for D1 and D2 enclosures. The duct work for E1 enclosures has a different appearance, but is installed in the same way.



For the E1 enclosures, it is important to mount the plate at the absolute rear of the Rittal enclosure due to the weight of the adjustable frequency drive.

Ordering Information

Rittal TS-8 Enclosure	Frame D3 Kit Part No.	Frame D4 Kit Part No.	Frame E2 Part No.
70.9 in [1800 mm]	176F1824	176F1823	Not possible
78.7 in [2000 mm]	176F1826	176F1825	176F1850
86.6 in [2200 mm]			176F0299

Kit Contents

- Ductwork components
- Mounting hardware
- Gasket material
- Delivered with D1 and D2 frame kits:
 - 175R5639 - Mounting templates and top/bottom cut-out for Rittal enclosure.
- Delivered with E1 frame kits:
 - 175R1036 - Mounting templates and top/bottom cut-out for Rittal enclosure.

All fasteners are either:

- 0.39 in [10 mm], M5 Nuts torque to 2.3 Nm (20 in-lbs)
- T25 Torx screws torque to 2.3 Nm (20 in-lbs)

3.4.1. Installation of Rittal Enclosures

This illustration shows the full size template included with the kit and two drawings that may be used to locate the cut-outs for the top and bottom enclosure plates. The duct work may also be used to locate the openings.

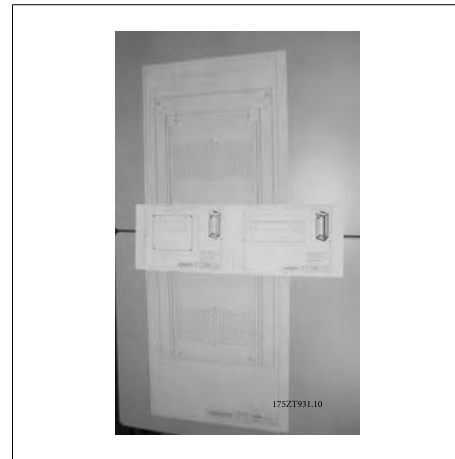

3.29: Templates

3

Install the gasket material on the back openings of the adjustable frequency drive prior to installation on the enclosure's back panel. Use the template provided with the kit (shown above), and install the adjustable frequency drive on the enclosure's back panel of the Rittal. The template is referenced to the top-left corner of the back panel. Therefore, the template may be used with any size back panel and both the 71 in [1800 mm] and 79 in [2000 mm] high enclosures.



3.30: The openings on the rear not used in this application.

Before installing the back panel in the enclosure, assemble the gasket on both sides of the bottom duct adapter as shown below, and install on the bottom of the adjustable frequency drive.

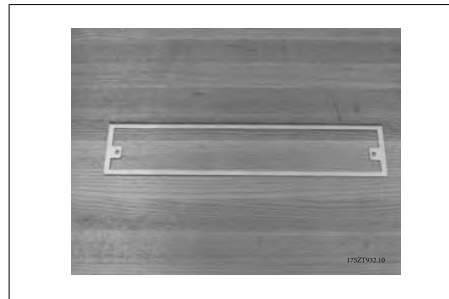

3.31: Bottom duct adapter



3.32: Bottom duct adapter with gasket installed



3.33: Bottom duct adapter installed

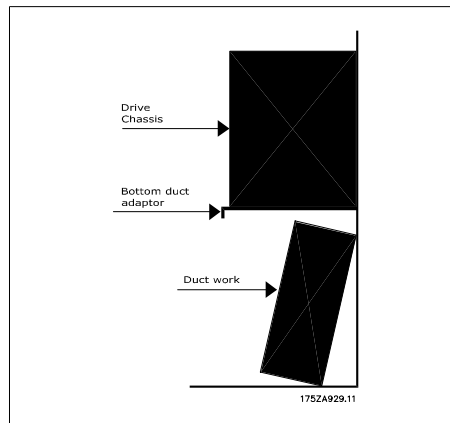

3.34: Side view



NOTE

Install the bottom plate after the adjustable frequency drive has been installed on the back to assure proper gasket coverage.

Install the two mounting brackets on the adjustable frequency drive chassis, and then install the bottom duct adapter on the bottom of the adjustable frequency drive as shown below.

The installation of the bottom plate is easier when the back panel is outside the enclosure. The curved leading edge of the bottom duct adapter is to the front of the adjustable frequency drive and down.

Before installing the back panel with the adjustable frequency drive in the Rittal TS8 enclosure, remove and discard the rearmost 5 screws (see illustration below) located on the top cover of the adjustable frequency drive. The holes will be used to fasten the top duct work with the longer screws provided with the kit.

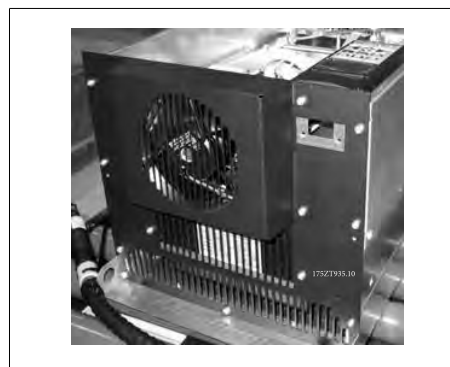

3.35: Top of IP 00/Chassis adjustable frequency drive

3

Install the back panel in the enclosure, see illustration below. Use Rittal PS4593.000 brackets (minimum one per side at the middle of the adjustable frequency drive) with the appropriate support strip for additional support of the back panel. For the D4 and E2 frame, use two supports per side. If additional components are mounted on the same back panel, consult the Rittal manual for additional support requirements.



3.36: Adjustable frequency drive installed in cabinet

3.4.2. Installation of Rittal Enclosures, cont.

The top ductwork cover is composed of the following pieces as shown below. From left to right: 1. top duct closing plate, 2. adjustable frequency drive bracket, 3. duct, 4. duct vented-top cover.

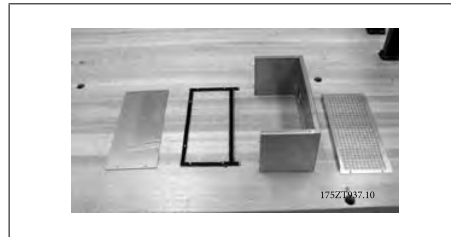

3.37: Top duct assembly



3.38: Top duct work and enclosure top installed

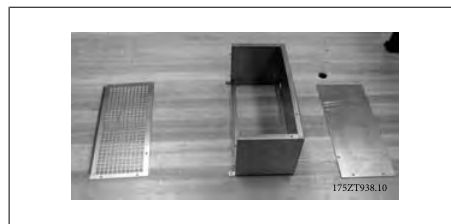

3.39: The top duct work partially assembled with adjustable frequency drive bracket

Temporarily install the top duct section as shown above. Use the top duct cover piece to mark the enclosure top for the opening. Alternatively, the mounting template (supplied drawing) can be used to make the enclosure cutout.



3.40: Rittal enclosure top with cut-out
The standard Rittal enclosure top is cut. The gasket is not used on the cut-out. The gasket is part of the duct work.



3.41: The gasket folds over the edge to form a seal between the duct and the top vented cover.

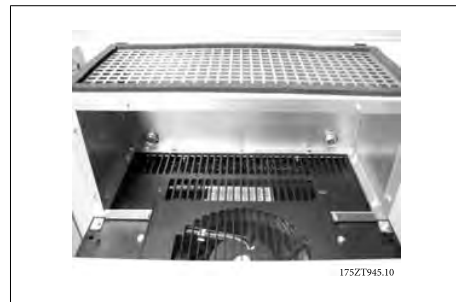

3.42: Top duct installed



3.43: The gasket applied to both sides of the adjustable frequency drive bracket and duct vented-top cover.



3.44: Top duct ready to be installed on the adjustable frequency drive

3

For the final installation of the duct work, assemble the top duct as shown below.

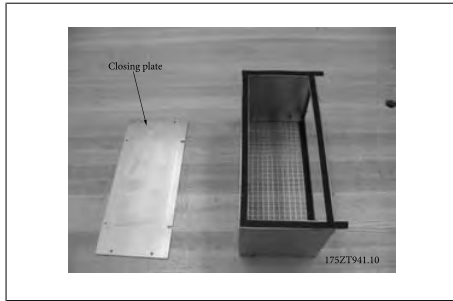

3.45: Top duct assembled with gasket

The top duct closing plate is left off for the installation of the duct work on the adjustable frequency drive. The top duct work is attached to the adjustable frequency drive using existing holes on the top cover of the adjustable frequency drive. Use the longer T25 screws provided with the kit in the existing adjustable frequency drive top cover holes. The duct work will fit over the adjustable frequency drive mounting bolts.

Once the duct work is attached to the adjustable frequency drive, the duct closing plate can be attached. The top duct work assembly is complete.

Apply the gasket to the top duct closing plate and install. Install the enclosure top. Top duct installation is complete.



3.46: Top duct installed

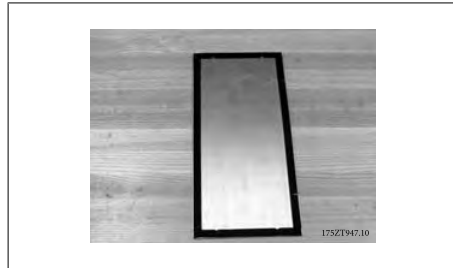

3.47: Top duct closing plate with gasket

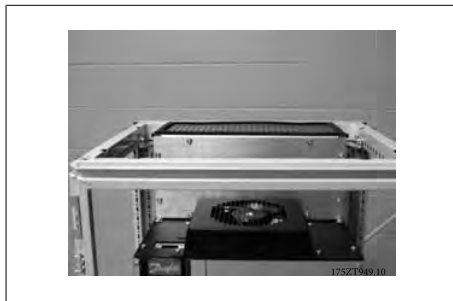

3.48: Top duct closing plate installed



3.49: Enclosure top installed



3.50: Top view of Rittal enclosure

3.4.3. Installation of Rittal Enclosures, cont.

The bottom duct assembly pieces. Refer to the drawing showing the exploded view of the duct work components. The gasket is installed as shown. Assemble the bottom duct without the cover. The assembly includes the mounting of 3 angle brackets on the front and sides of the partially assembled bottom duct. The bottom duct collar is bolted to the duct using 3 - T25 screws in the outermost holes of the brackets. Tighten the screws to compress the gasket.



3.51: Bottom duct work pieces

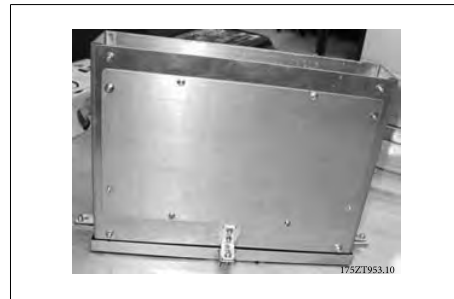

3.53: Completely assembled bottom duct work



3.52: Bottom duct work partially assembled

3

The duct assembly is used to mark the bottom cut-out. Temporarily install the bottom duct work as shown to the right. Use the inside of the duct work to mark the bottom of the enclosure for the opening.

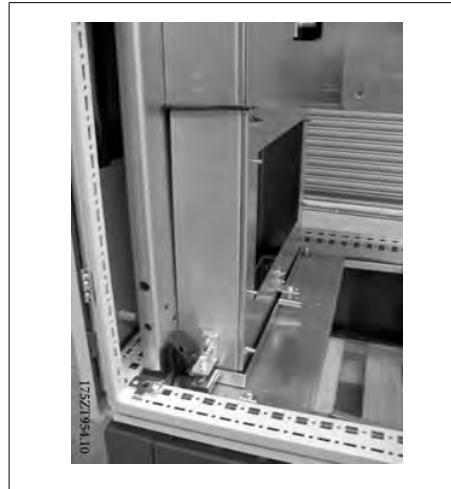

3.54: Temporarily install the duct work to mark the cut-out on the gland.

The cut-out is made on the innermost gland plate. The remaining two gland plates must be removed for the installation of the bottom duct assembly.

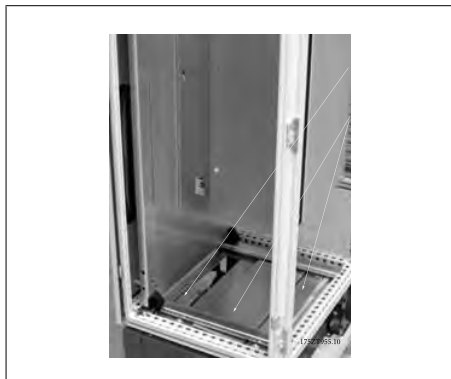

3.55: Enclosure bottom cut-out

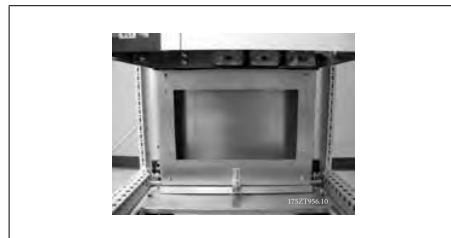

3.56: Bottom duct work installed

The bottom duct work is rotated into place as shown. The bottom ductwork is a tight fit by design. The upper part of the duct fits under the bottom duct adapter and requires a tight fit, which, with the gasket material, maintains the IP 54 and UL and NEMA 12 rating.

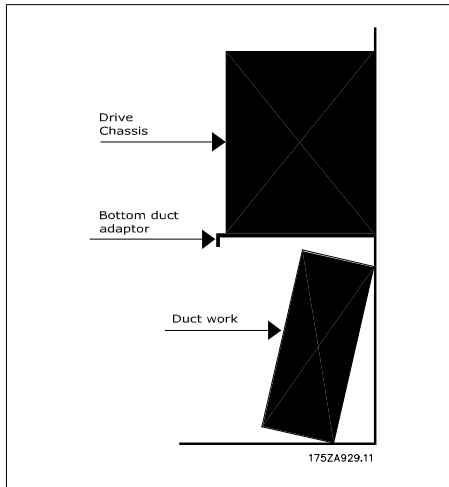

3.57: Installation of bottom duct

After the bottom duct work has been positioned in place, remove the three T25 screws from the outer holes in the mounting brackets on the sides and front of duct work and move them to the inner holes of the same brackets. Tighten the three screws to the specified torque. The bottom duct work is not fastened to the Rittal enclosure.

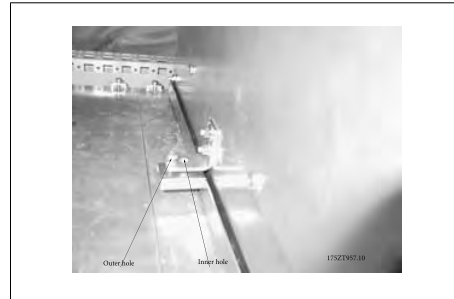

3.58: Move mounting screws from the outer hole to the inner hole

Install the front cover of the duct and the cable clamp base if used. Install the two remaining gland plates.



3.59: Bottom duct installed.

3.4.4. Installation on pedestal

The adjustable frequency drive can also be installed on the floor. A dedicated floor stand is designed for that purpose. It can only be used for units produced after week 50, 2004 (serial number XXXXXG504).

This section describes the installation of a pedestal unit available for the VLT series adjustable frequency drives frames D1 and D2. This is an 8 in [200 mm] high pedestal that allows these frames to be floor mounted. The front of the pedestal has openings for input air to the power components.

The adjustable frequency drive gland plate must be installed to provide adequate cooling air to the control components of the adjustable frequency drive via the door fan and to maintain the IP 21/NEMA 1 or IP 54/NEMA 12 degrees of enclosure protections.

There is one pedestal that fits both frames D1 and D2.

Required Tools:

- Socket wrench with 7-17 mm sockets
- T30 Torx Driver

Torques:

- M6 - 4.0 Nm (35 in-lbs)
- M8 - 9.8 Nm (85 in-lbs)
- M10 - 19.6 Nm (170 in-lbs)

Kit Contents:

- Pedestal parts
- Instruction Manual



3.60: Drive on pedestal.

The kit contains a U-shaped piece, a vented front cover, 2 side covers, two front brackets and the required hardware to assemble. See the exploded view of the installation, illustration "Three front screws" (drawing 130BA647).



3.61: Pedestal parts

The pedestal has been partially assembled. Before installing the drive on to the pedestal, it is important to anchor the pedestal to the floor using the four pedestal mounting holes. The holes can accommodate up to M12 bolts (not included in the kit).

CAUTION: The drives are top heavy and may fall over if the pedestal is not anchored to the floor.

The entire assembly may also be supported by using the drive top mounting holes to anchor it to a wall structure.



3.62: Pedestal partially assembled

The completely assembled pedestal with vented front cover and two side covers installed. Multiple adjustable frequency drives may be mounted side by side. The interior side closing plates are left off.

NOTE: The front and side cover mounting screws are now recessed M6 Torx socket flat head screws.



3.63: Final assembled pedestal.

3

Install the adjustable frequency drive by lowering it onto the pedestal. The adjustable frequency drive must hang over the front of the pedestal to clear the retaining bracket on the rear of the pedestal. After the adjustable frequency drive has been placed on the pedestal, slide the adjustable frequency drive so that it engages with the retaining bracket on the pedestal and mount screws as shown.

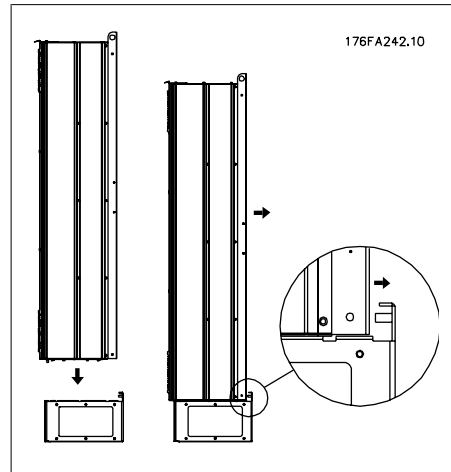

3.64: Mount the drive onto pedestal.

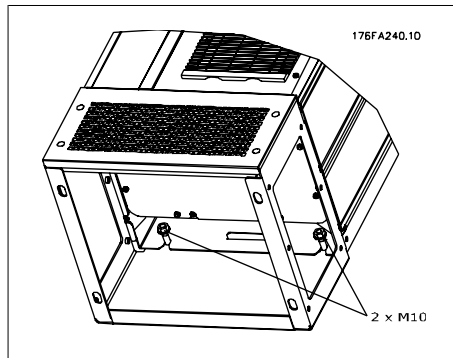

3.65: Two nuts at rear side.

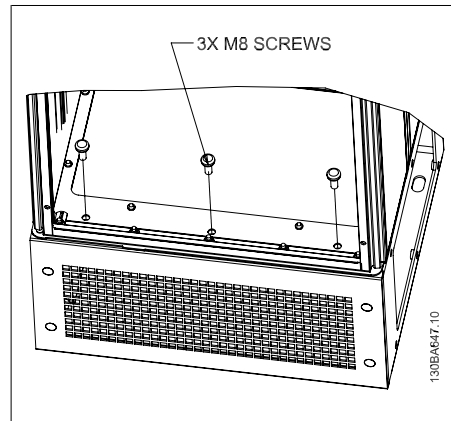

3.66: Three front screws.



3.67: Frame D2 with pedestal installed

3.5. Electrical Installation

3.5.1. Control Wires

Connect the wires as described in the Instruction Manual for the adjustable frequency drive. Remember to connect the shields properly to ensure optimum electrical immunity.

Control cable routing

Tie down all control wires to the designated control cable routing.

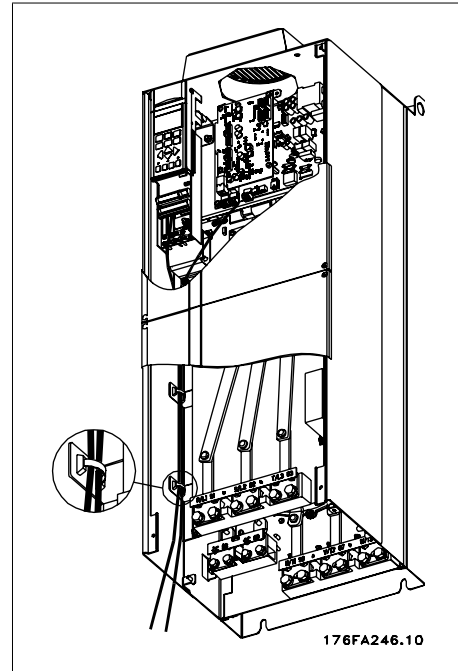

3.68: Wire path for control wiring.

Serial communication bus connection

Connections are made to the relevant options at the control card. For details, see the relevant serial communication bus instructions. The cable must be placed to the left, inside the adjustable frequency drive and tied down together with other control wires.

In the IP 00 (chassis) and IP 21 (NEMA 1) units, it is also possible to connect the serial communication bus from the top of the unit as shown on the picture below. On the IP 21 (NEMA 1), unit a cover plate must be removed.



3.69: Top connection for the serial communication bus.

3

Installation of 24 Volt external DC Supply

Torque: 0.5 - 0.6 Nm (5 in-lbs)
Screw size: M3

No.	Function
35 (-), 36 (+)	24 V external DC supply

24 V external DC supply can be used as low-voltage supply to the control card and any option cards installed. This enables full operation of the LCP (incl. parameter setting) without connection to line power. Please note that a low voltage warning is issued when 24 V DC has been connected; however, there will be no tripping.

 Use a 24 V DC supply of type PELV to ensure correct galvanic isolation (type PELV) on the control terminals of the adjustable frequency drive.

3.5.2. Power Connections

Cabling and Fusing

 **NOTE**
Cables General
All cabling must comply with national and local regulations on cable cross-sections and ambient temperature. Copper (167° F [75° C]) conductors are recommended.

The power cable connections are laid out as shown below. Dimensioning of cable cross-sections must be done in accordance with the current ratings and local legislation. See the *Specifications section* for details.

To protect the adjustable frequency drive, the recommended fuses must be used or the unit must have built-in fuses. Recommended fuses are listed in the tables in the fuses section. Always ensure that proper fusing is done according to local regulations.

The line connection is fitted to the line switch if this is included.

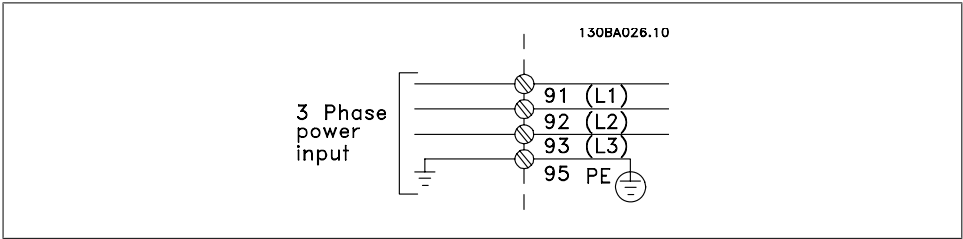

NOTE
Motor cable must be shielded/armored. The use of an unshielded/unarmored cable is against EMC requirements. Use a shielded/armored motor cable to comply with EMC emission specifications. For more information, see *EMC specifications* in the *Design Guide*.

See section General Specifications for correct dimensioning of motor cable cross-section and length.

Shielding of cables:

Avoid installation with twisted shield ends (pigtailed), as they reduce the shielding effect at higher frequencies. They spoil the shielding effect at higher frequencies. If it is necessary to break the shield to install a motor isolator or motor contactor, the shield must be continued at the lowest possible HF impedance.

Connect the motor cable shield to both the de-coupling plate of the adjustable frequency drive and to the metal housing of the motor.

Make the shield connections with the largest possible surface area (cable clamp). This is done by using the supplied installation devices in the adjustable frequency drive.

Cable length and cross-section:

The adjustable frequency drive has been tested with a given length of cable and a given cross-section of that cable. If the cross-section is increased, the cable capacitance - and thus the leakage current - may increase, thereby requiring that the cable length is reduced accordingly. Keep the motor cable as short as possible to reduce the noise level and leakage currents. Details can be found in the relevant Design Guide.

Switching frequency:

When adjustable frequency drives are used together with sine-wave filters to reduce the acoustic noise from a motor, the switching frequency must be set according to the instructions in par. 14-01.

Term. no.	96	97	98	99	
	U	V	W	PE ¹⁾	Motor voltage 0-100% of line voltage. 3 wires out of motor
	U1 W2	V1 U2	W1 V2	PE ¹⁾	Delta-connected 6 wires out of motor
	U1	V1	W1	PE ¹⁾	Star-connected U2, V2, W2 U2, V2 and W2 to be interconnected separately.

¹⁾Protected Ground Connection

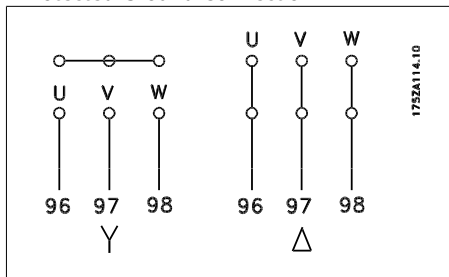

NOTE
In motors without phase insulation paper or other insulation reinforcement suitable for operation with voltage supply (such as an adjustable frequency drive), fit a sine-wave filter on the output of the adjustable frequency drive.

3

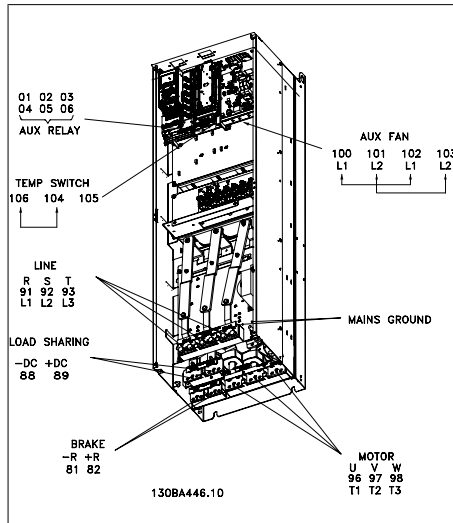

3.70: Compact IP 00 (Chassis), enclosure D3

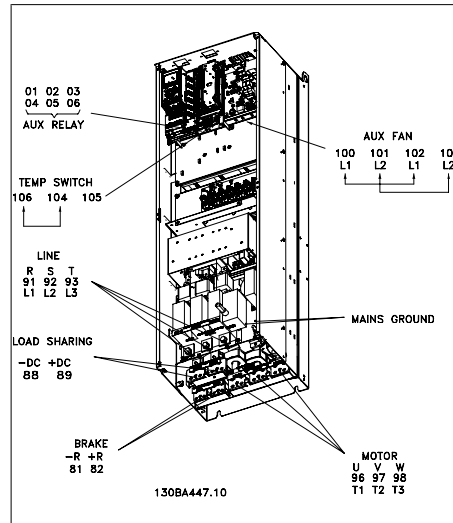

3.72: Compact IP 00 (Chassis) with disconnect, fuse and RFI filter, enclosure D4

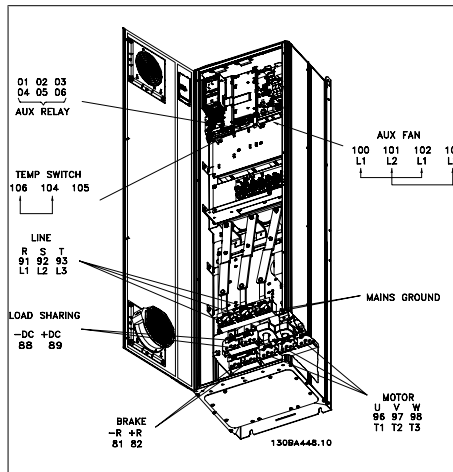

3.71: Compact IP 21 (NEMA 1) and IP 54 (NEMA 12), enclosure D1

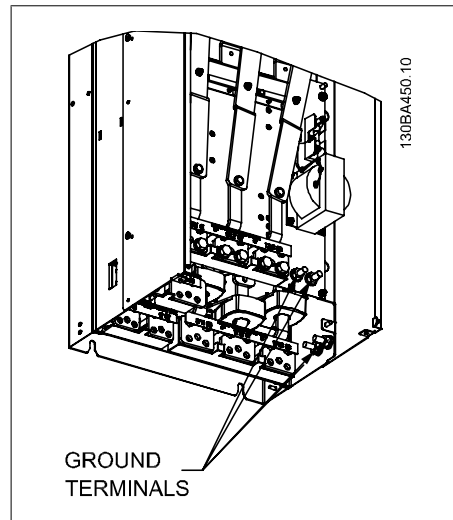

3.73: Position of ground terminals IP 00, D enclosures

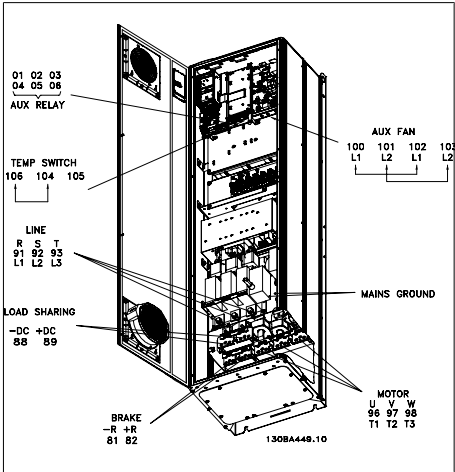

3.74: Compact IP 21 (NEMA 1) and IP 54 (NEMA 12) with disconnect, fuse and RFI filter, enclosure D2

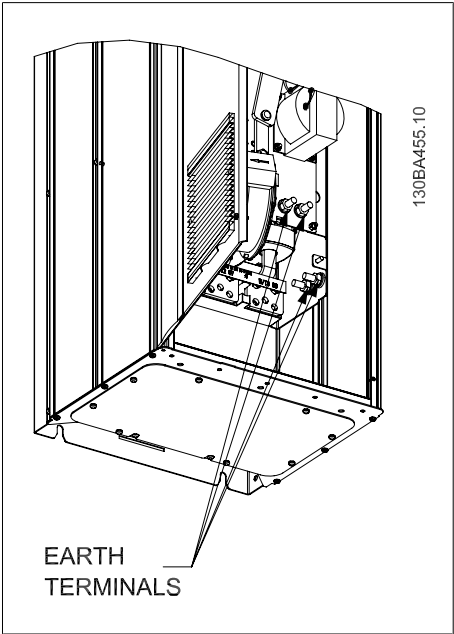

3.75: Position of ground terminals IP 21 (NEMA type 1) and IP 54 (NEMA type 12)

3

3

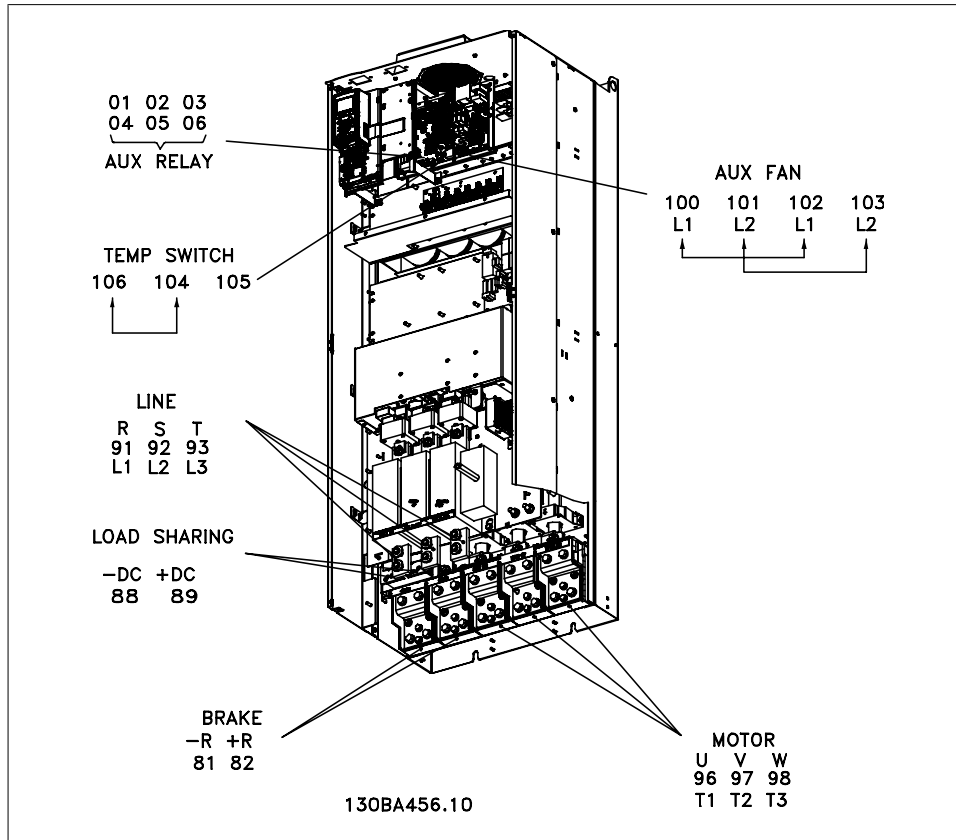

3.76: Compact IP 00 (Chassis) with disconnect, fuse and RFI filter, enclosure E2

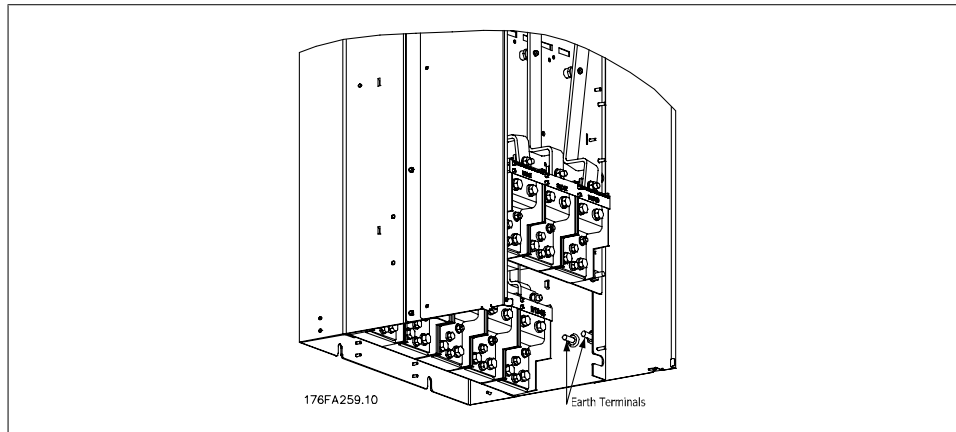

3.77: Position of ground terminals IP 00, E enclosures

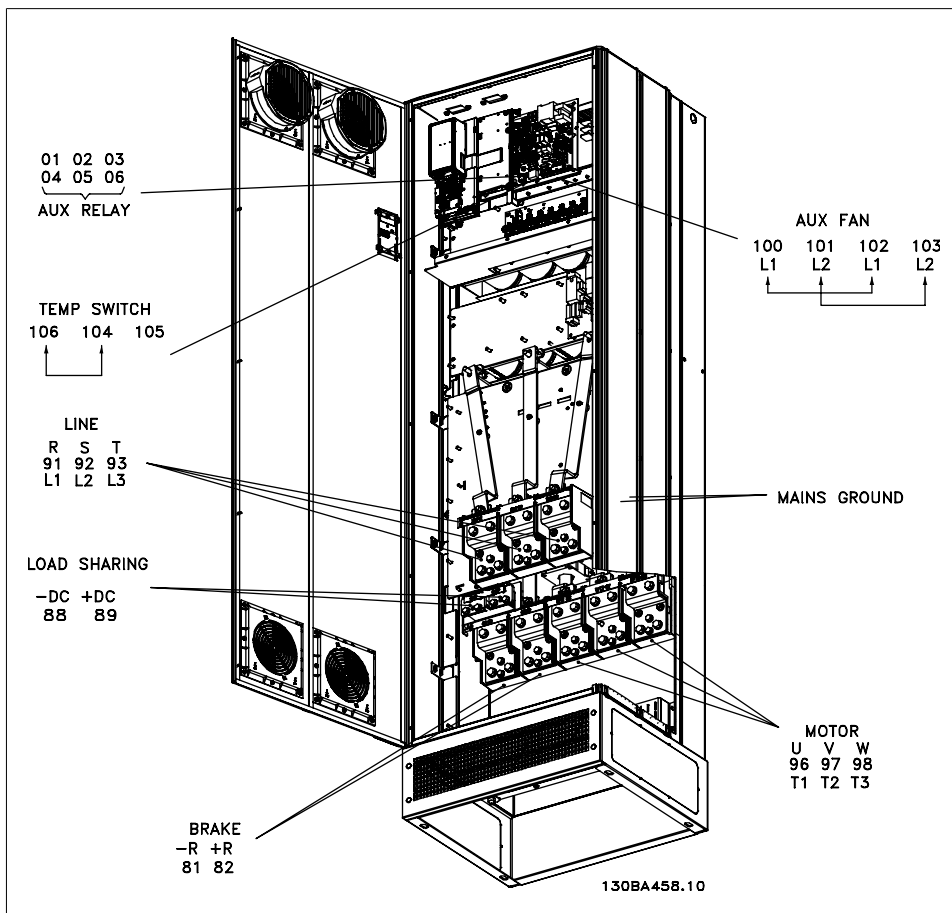

3.78: Compact IP 21 (NEMA 1) and IP 54 (NEMA 12) enclosure E1

3.5.3. Grounding

The following basic issues need to be considered when installing an adjustable frequency drive, so as to obtain electromagnetic compatibility (EMC).

- Safety grounding: Please note that the adjustable frequency drive has a high leakage current and must be grounded appropriately for safety reasons. Always follow local safety regulations.
- High-frequency grounding: Keep the ground wire connections as short as possible.

Connect the different ground systems at the lowest possible conductor impedance. The lowest possible conductor impedance is obtained by keeping the conductor as short as possible and by using the greatest possible surface area.

The metal cabinets of the different devices are mounted on the cabinet rear plate using the lowest possible HF impedance. This prevents having different HF voltages for the individual devices and prevents the risk of radio interference currents running in connection cables that may be used between the devices, as radio interference is reduced.

In order to obtain a low HF impedance, use the fastening bolts of the devices as HF connections to the rear plate. It is necessary to remove insulating paint and the like from the fastening points.

3.5.4. Extra Protection (RCD)

ELCB relays, multiple protective grounding or grounding can be used as extra protection, provided that local safety regulations are complied with.

In the case of a ground fault, a DC content may develop in the faulty current.

If ELCB relays are used, local regulations must be observed. Relays must be suitable for protection of 3-phase equipment with a bridge rectifier and for a brief discharge on power-up.

See also the section *Special Conditions* in the relevant Design Guide.

3.5.5. RFI Switch

Line supply isolated from ground

If the adjustable frequency drive is supplied from an isolated line power source (IT line power, floating delta and grounded delta) or TT/TN-S line power with grounded leg, it is recommended that the RFI switch be turned off (OFF) ¹⁾ via par. 14-50. For further reference, see IEC 364-3. If optimum EMC performance is needed, parallel motors are connected or the motor cable length is above 82 ft [25 m], it is recommended to set par. 14-50 to [ON].

¹⁾ Not required with 525-600/690 V drives; therefore not possible.

In OFF, the internal RFI capacities (filter capacitors) between the chassis and the intermediate circuit are cut off to avoid damage to the intermediate circuit and to reduce the ground capacity currents (according to IEC 61800-3).

Please also refer to the application note *VLT on IT line power*, MN.90.CX.02. It is important to use isolation monitors that are capable of being used with power electronics (IEC 61557-8).

3.5.6. Torque

When tightening all electrical connections, it is very important to tighten with the correct torque. Too low or too high torque results in a bad electrical connection. Use a torque wrench to ensure correct torque.

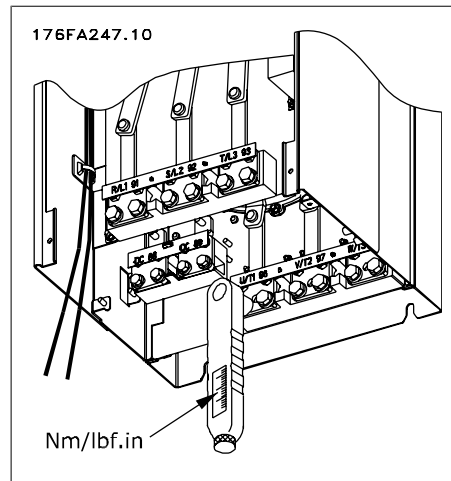

3.79: Always use a torque wrench to tighten the bolts.

Enclosure	Terminal	Torque	Bolt size
D1, D2, D3 and D4	Line Power	19 Nm (168 in-lbs)	M10
	Motor		
	Load sharing Brake	9.5 (84 in-lbs)	M8
E1 and E2	Line Power	19 NM (168 in-lbs)	M10
	Motor		
	Load sharing		
	Brake	9.5 (84 in-lbs)	M8

3.4: Torque for terminals

3.5.7. Shielded Cables

It is important that shielded and armored cables are connected properly to ensure high EMC immunity and low emissions.

Connection can be made with either cable glands or clamps:

- EMC cable glands: generally available cable glands can be used to ensure an optimum EMC connection.
- EMC cable clamp: Clamps allowing for easy connection are supplied with the adjustable frequency drive.

3.5.8. Motor cable

The motor must be connected to terminals U/T1/96, V/T2/97, W/T3/98. Ground to terminal 99. All types of three-phase asynchronous standard motors can be used with an adjustable frequency drive unit. The factory setting is for clockwise rotation with the VLT adjustable frequency drive output connected as follows:

Terminal No.	Function
96, 97, 98, 99	Line power U/T1, V/T2, W/T3 Ground/Earth

<ul style="list-style-type: none"> • Terminal U/T1/96 connected to U-phase • Terminal V/T2/97 connected to V-phase • Terminal W/T3/98 connected to W-phase 	

The direction of rotation can be changed by switching two phases in the motor cable or by changing the setting of par. 4-10.

3.5.9. Brake Cable

(Only standard with letter B in position 18 of typecode).

Terminal No.	Function
81, 82	Brake resistor terminals

The connection cable to the brake resistor must be shielded. Connect the shield by means of cable clamps to the conductive back plate at the adjustable frequency drive and to the metal cabinet of the brake resistor.

Size the brake cable cross-section to match the brake torque. See also *Brake Instructions, MI.90.Fx.yy* and *MI.50.Sx.yy* for further information regarding safe installation.

Please note that voltages up to 1099 V DC, depending on the supply voltage, may occur on the terminals.

3.5.10. Load Sharing

(Only extended with letter D in position 21 of the typecode).

Terminal No.	Function
88, 89	Load sharing

The connection cable must be shielded, and the max. length from the adjustable frequency drive to the DC bar is 81 ft [25 m].

Load sharing enables the linking of the DC intermediate circuits of several adjustable frequency drives.

Please note that voltages up to 1099 V DC may occur on the terminals. Load sharing calls for extra equipment. For further information, please contact Danfoss.

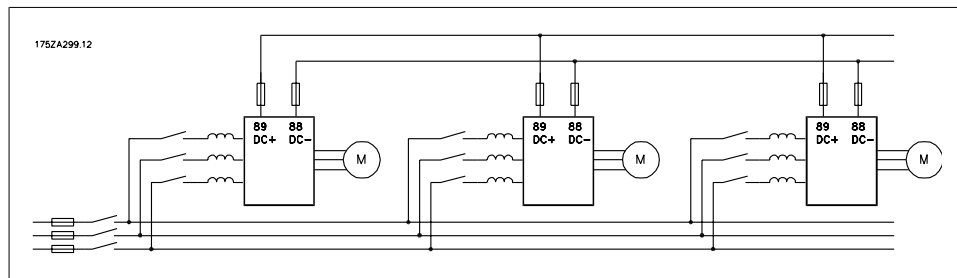

3.80: Load sharing connection

3.5.11. Shielding against Electrical Noise

Before mounting the line power cable, mount the EMC metal cover to ensure best EMC performance.

NOTE: The EMC metal cover is only included in units with an RFI filter.

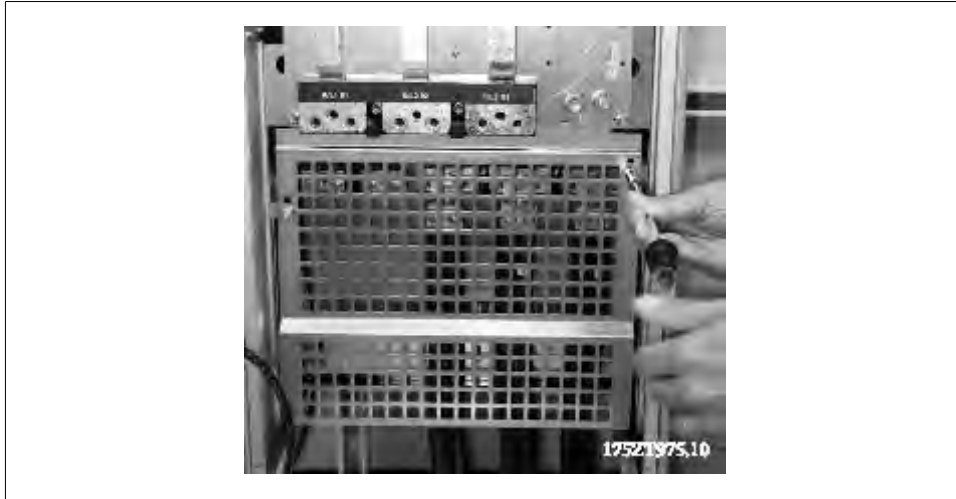

3.81: Mount the EMC shield.

3.5.12. Line connection

The line power supply must be connected to terminals 91, 92 and 93. Ground is connected to the terminal to the right of terminal 93.

Terminal No.	Function
91, 92, 93	Line power R/L1, S/L2, T/L3
94	Ground/Earth

 Check the nameplate to ensure that the line voltage of the adjustable frequency drive matches the power supply of your plant.

Ensure that the power supply can supply the necessary current to the adjustable frequency drive.

If the unit is without built-in fuses, ensure that the appropriate fuses have the correct current rating.

3.5.13. External Fan Supply

If the adjustable frequency drive is supplied by DC or if the fan must run independently of the power supply, an external power supply can be applied. The connection is made to the power card.

Terminal No.	Function
100, 101	Auxiliary supply S, T
102, 103	Internal supply S, T

The connector located on the power card provides the line voltage connection for the cooling fans. The fans are factory-equipped to be supplied from a common AC line (jumpers between 100-102 and 101-103). If an external supply is needed, the jumpers are removed and the supply is connected to terminals 100 and 101. A 5 Amp fuse should be used for protection. In UL applications, this should be Littelfuse KLK-5 or equivalent.

3.5.14. Fuses

Branch circuit protection:

In order to protect the installation against electrical and fire hazard, all branch circuits in an installation, switch gear, machines, etc., must be short-circuited and overcurrent protected according to national/international regulations.

Short-circuit protection:

The adjustable frequency drive must be protected against short circuit in order to prevent electrical or fire hazard. Danfoss recommends using the fuses mentioned below to protect service personnel and equipment in case of an internal failure in the drive. The adjustable frequency drive provides full short-circuit protection in case of a short-circuit on the motor output.

Overcurrent protection

Provide overload protection to avoid fire hazard due to overheating of the cables in the installation. The adjustable frequency drive is equipped with internal overcurrent protection that can be used for upstream overload protection (UL applications excluded). See par. 4-18. Moreover, fuses or circuit breakers can be used to provide the overcurrent protection in the installation. Overcurrent protection must always be carried out according to national regulations.

Fuses must be designed for protection in a circuit capable of supplying a maximum of 100,000 A_{rms} (symmetrical).

Fuse Tables

Size/ Type	Buss- mann E1958 JFHR2* *	Buss- mann E4273 T/ JDDZ**	SIBA E180276 RKI/JDDZ	LittelFuse E71611 JFHR2**	Ferraz- Shawmut E60314 JFHR2**	Buss- mann E4274 H/ JDDZ**	Bussmann E125085 JFHR2*	Internal Option Bussmann
P90K	FWH- 300	JJS- 300	2028220- 315	L50S-300	A50-P300	NOS- 300	170M3017	170M3018
P110	FWH- 350	JJS- 350	2028220- 315	L50S-350	A50-P350	NOS- 350	170M3018	170M3018
P132	FWH- 400	JJS- 400	206xx32- 400	L50S-400	A50-P400	NOS- 400	170M4012	170M4016
P160	FWH- 500	JJS- 500	206xx32- 500	L50S-500	A50-P500	NOS- 500	170M4014	170M4016
P200	FWH- 600	JJS- 600	206xx32- 600	L50S-600	A50-P600	NOS- 600	170M4016	170M4016

3.5: D enclosures, 380-500 V

*170M fuses from Bussmann shown use the -/80 visual indicator; -TN/80 Type T, -/110 or TN/110 Type T indicator fuses of the same size and amperage may be substituted for external use

**Any minimum 500 V UL listed fuse with associated current rating may be used to meet UL requirements.

Size/Type	Bussmann E125085 JFHR2	Amps	SIBA E180276 JFHR2	Ferraz-Shawmut E76491 JFHR2
P110	170M3017	315	2061032.315	6.6URD30D08A0315
P132	170M3018	350	2061032.35	6.6URD30D08A0350
P160	170M4011	350	2061032.35	6.6URD30D08A0350
P200	170M4012	400	2061032.4	6.6URD30D08A0400
P250	170M4014	500	2061032.5	6.6URD30D08A0500
P315	170M5011	550	2062032.55	6.6URD32D08A550

3.6: D enclosures, 525-690 V

Size/Type	Bussmann PN*	Danfoss PN	Rating	Losses (W)
P250	170M4017	20220	700 A, 700 V	85
P315	170M6013	20221	900 A, 700 V	120
P355	170M6013	20221	900 A, 700 V	120
P400	170M6013	20221	900 A, 700 V	120

3.7: E enclosures, 380-500 V

*170M fuses from Bussmann shown use the -/80 visual indicator; -TN/80 Type T, -/110 or TN/110 Type T indicator fuses of the same size and amperage may be substituted for external use.

Danfoss PN	Bussmann	Ferraz	Siba
20220	170M4017	6.9URD31D08A0700	20 610 32.700
20221	170M6013	6.9URD33D08A0900	20 630 32.900

3.8: Additional Fuses for Non-UL Applications, E enclosures, 380-500 V

3

Size/Type	Bussmann PN*	Danfoss PN	Rating	Losses (W)
P355	170M4017	20220	700 A, 700 V	85
P400	170M4017	20220	700 A, 700 V	85
P500	170M6013	20221	900 A, 700 V	120
P560	170M6013	20221	900 A, 700 V	120

3.9: E enclosures, 525-690 V

*170M fuses from Bussmann shown use the -/80 visual indicator; -TN/80 Type T, -/110 or TN/110 Type T indicator fuses of the same size and amperage may be substituted for external use.

Danfoss PN	Bussmann	Ferraz	Siba
20220	170M4017	6.9URD31D08A0700	20 610 32.700
20221	170M6013	6.9URD33D08A0900	20 630 32.900

3.10: Additional Fuses for Non-UL Applications E enclosures, 525-690 V

Suitable for use on a circuit capable of delivering not more than 100,000 rms symmetrical amperes, 500/600/690 Volts maximum when protected by the above fuses.

Circuit Breaker Tables

Circuit Breakers manufactured by General Electric, Cat. No. SKHA36AT0800, 600 V AC maximum, with the rating plugs listed below can be used to meet UL requirements.

Size/Type	Rating plug catalog #	Amps
P90	SRPK800A300	300
P110	SRPK800A400	400
P132	SRPK800A400	400
P160	SRPK800A500	500
P200	SRPK800A600	600

3.11: D enclosures, 380-500 V

Non-UL compliance

If UL/cUL is not to be complied with, we recommend using the following fuses, which will ensure compliance with EN50178:

In case of malfunction, not following the recommendation may result in unnecessary damage to the adjustable frequency drive.

P110 - P200	380-500 V	type gG
P250 - P400	380-500 V	type gR

3.5.15. Brake Resistor Temperature Switch

Torque: 0.5-0.6 Nm (5 in-lbs)
Screw size: M3

This input can be used to monitor the temperature of an externally connected brake resistor. If the input between 104 and 106 opens, the adjustable frequency drive will trip on warning/alarm 27, "Brake IGBT". If the connection is closed between 104 and 105, the adjustable frequency drive will trip on warning/alarm 27, "Brake IGBT".

Normally closed: 104-106 (factory installed jumper)
Normally open: 104-105

Terminal No.	Function
106, 104, 105	Brake resistor temperature switch.



If the temperature of the brake resistor gets too high and the thermal switch drops out, the adjustable frequency drive will stop braking. The motor will start coasting. A KLIXON switch must be installed that is 'normally closed'. If this function is not used, 106 and 104 must be short-circuited together.

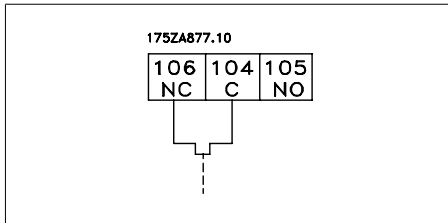

3.5.16. Access to Control Terminals

All terminals to the control cables are located beneath the LCP, accessed by opening the door of the IP 21/ 54 version or removing the covers of the IP 00 version.

3.5.17. Electrical Installation, Control Terminals

To connect the cable to the terminal:

1. Strip insulation of 0.34-0.39 in [9-10 mm]
2. Insert a screwdriver¹⁾ into the square hole.
3. Insert the cable in the adjacent circular hole.
4. Remove the screwdriver. The cable is now mounted to the terminal.

To remove the cable from the terminal:

1. Insert a screw driver¹⁾ in the square hole.
2. Pull out the cable.

¹⁾ Max. 0.015 x 0.1 in. [0.4 x 2.5 mm]

3

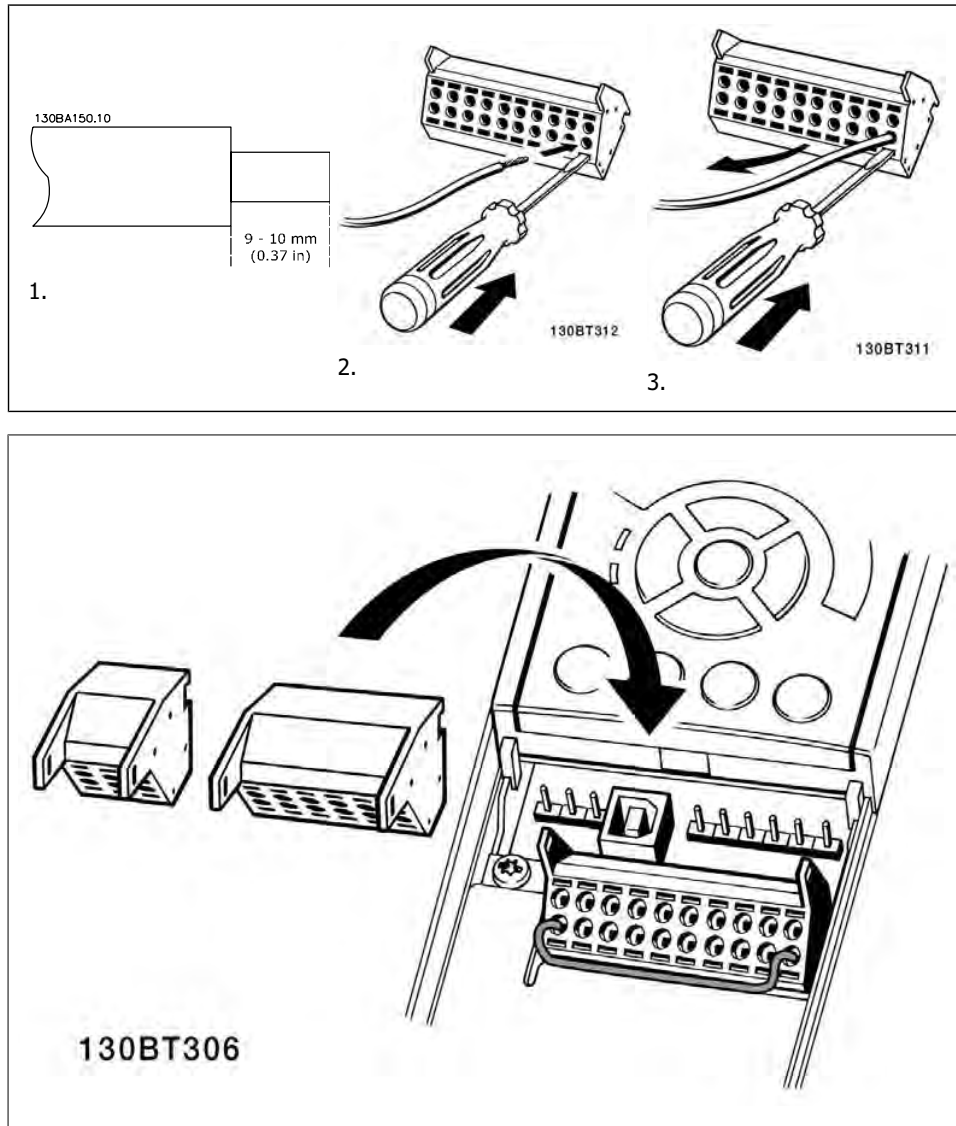

3.6. Connection Examples

3.6.1. Start/Stop

- Terminal 18 = Par. 5-10 [8] *Start*
- Terminal 27 = Par. 5-12 [0] *No operation (Default coast inverse)*
- Terminal 37 = Safe stop (where available!)

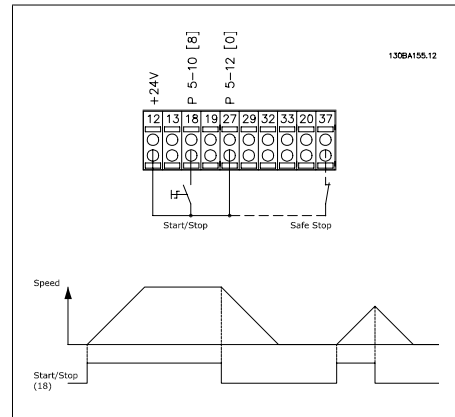

3

3.6.2. Pulse Start/Stop

- Terminal 18 = Par. 5-10 [9] *Latched start*
- Terminal 27 = Par. 5-12 [6] *Stop inverse*
- Terminal 37 = Safe stop (where available!)

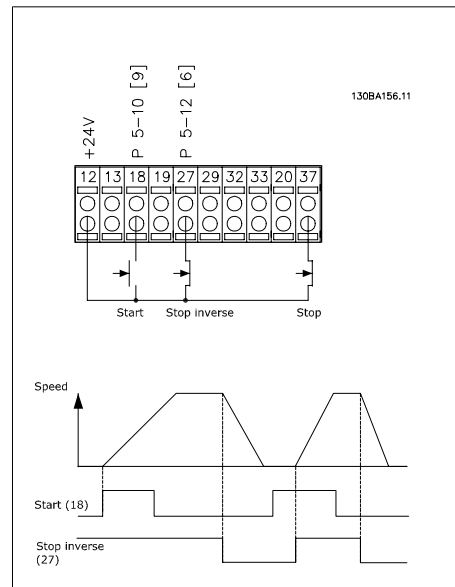

3

3.6.3. Speed Up/Slow

Terminals 29/32 = Speed up/Slow: .

Terminal 18 = Par. 5-10 [9] *Start* (default)

Terminal 27 = Par. 5-12 [19] *Freeze reference*

Terminal 29 = Par. 5-13 [21] *Speed up*

Terminal 32 = Par. 5-14 [22] *Slow*

Note: Terminal 29 only in FC x02 (x=series type).

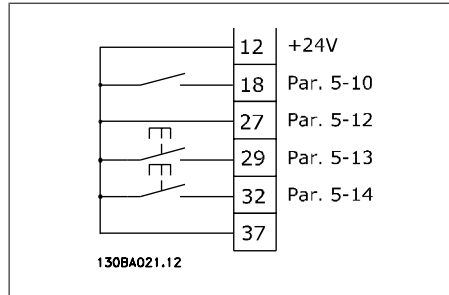

3.6.4. Potentiometer Reference

Voltage reference via a potentiometer:

Reference Source 1 = [1] *Analog input 53* (default)

Terminal 53, Low Voltage = 0 Volt

Terminal 53, High Voltage = 10 Volt

Terminal 53, Low Ref./Feedback = 0 RPM

Terminal 53, High Ref./Feedback = 1500 RPM

Switch S201 = OFF (U)

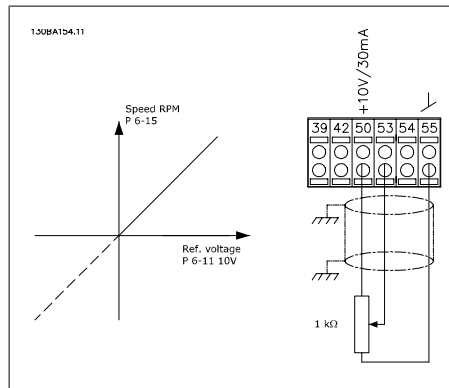

3.7.1. Electrical Installation, Control Cables

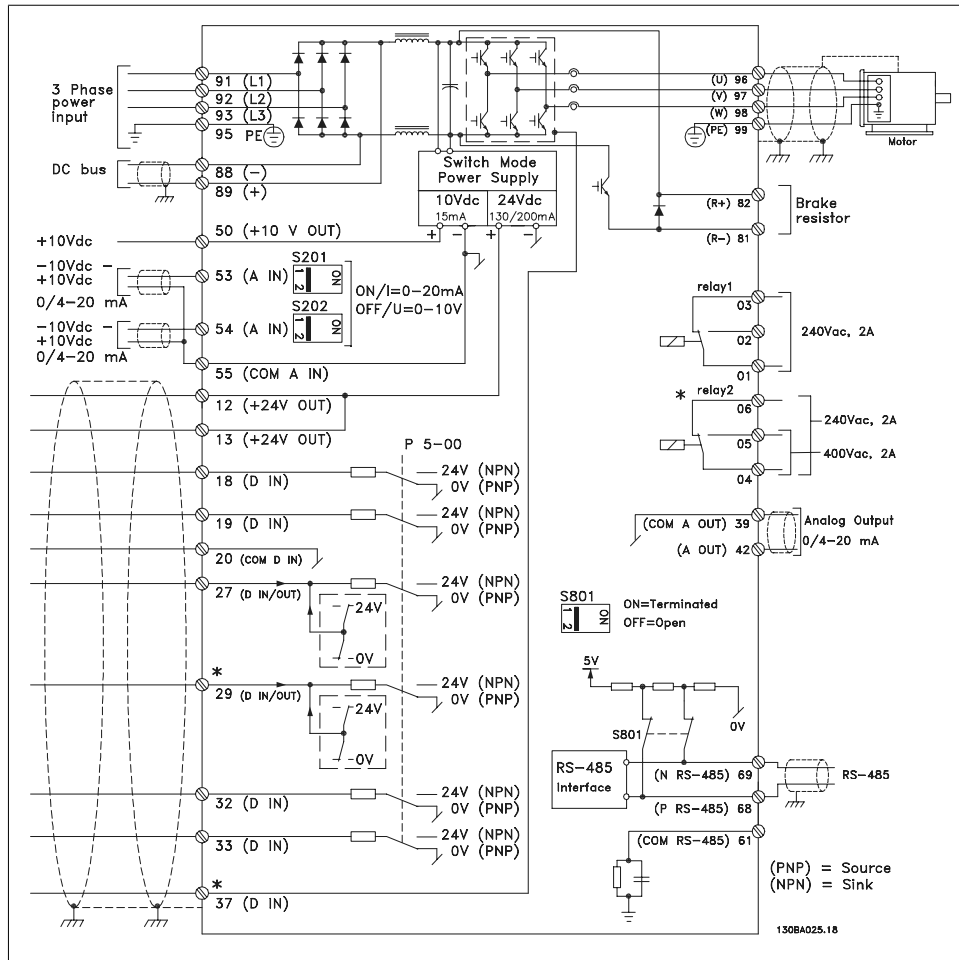

3

3.82: Diagram showing all electrical terminals without options.

Terminal 37 is the input to be used for Safe Stop. For instructions on safe stop installation, refer to the section *Safe Stop Installation* in the adjustable frequency drive Design Guide. See also sections Safe Stop and Safe Stop Installation.

In rare cases, very long control cables and analog signals may, depending on installation, result in 50/60 Hz ground loops due to noise from line supply cables.

If this occurs, it may be necessary to break the shield or insert a 100 nF capacitor between shield and chassis.

The digital and analog inputs and outputs must be connected separately to the adjustable frequency drive common inputs (terminal 20, 55, 39) to prevent ground currents from both groups from affecting other groups. For example, switching on the digital input may disturb the analog input signal.

3

Input polarity of control terminals

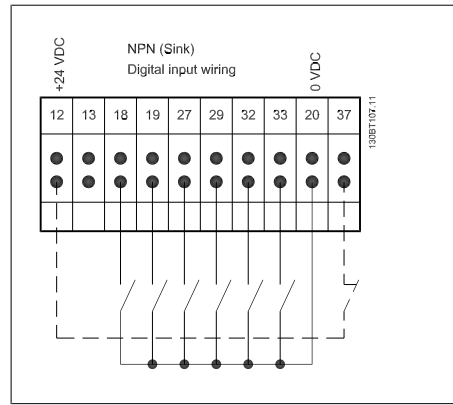
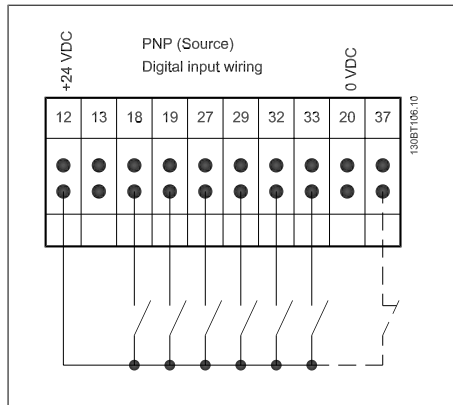

NOTE
Control cables must be shielded/armored.

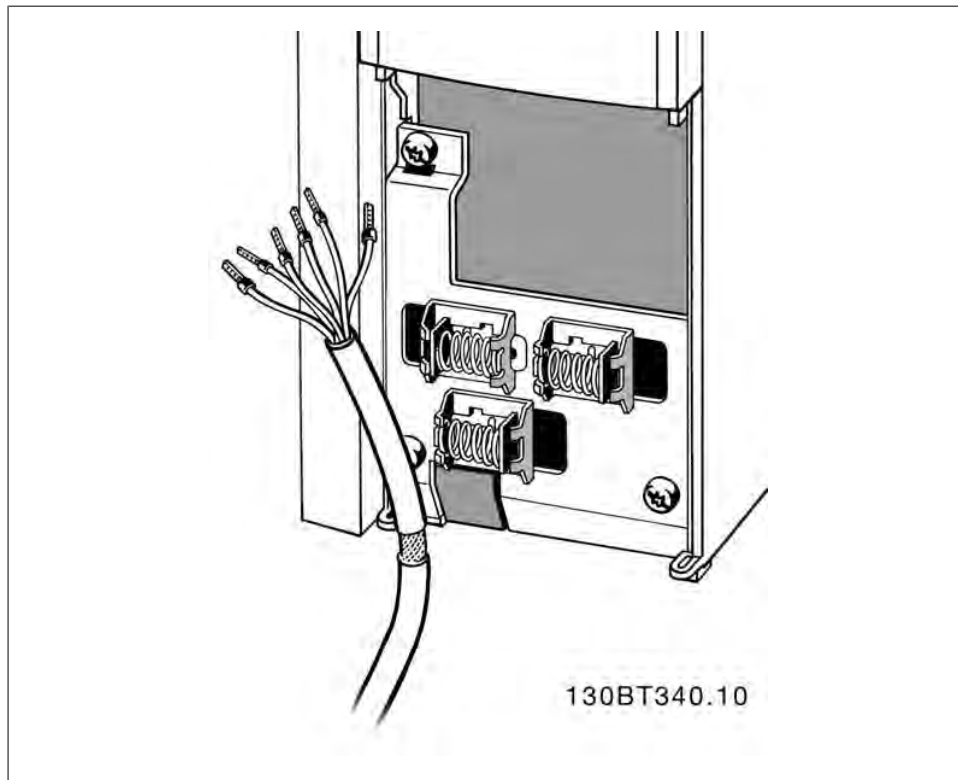

3.7.2. Switches S201, S202, and S801

Switches S201 (A53) and S202 (A54) are used to select a current (0-20 mA) or a voltage (-10 to 10 V) configuration for the analog input terminals 53 and 54, respectively.

Switch S801 (BUS TER.) can be used to enable termination on the RS-485 port (terminals 68 and 69).

See drawing *Diagram showing all electrical terminals* in section *Electrical Installation*.

Default setting:

S201 (A53) = OFF (voltage input)

S202 (A54) = OFF (voltage input)

S801 (Bus termination) = OFF



When changing the function of S201, S202 or S801, be careful not to force the switch over. Removing the LCP fixture (cradle) when operating the switches is recommended. The switches must not be operated while the adjustable frequency drive is powered.

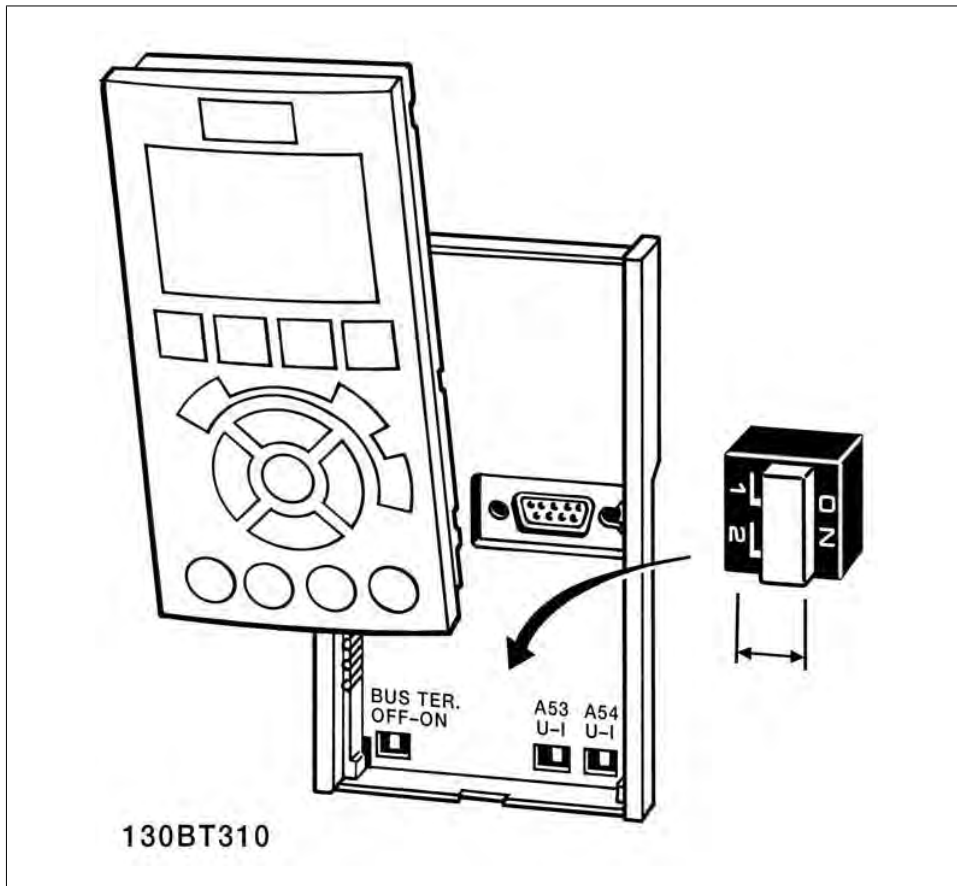

3.8. Final Set-Up and Test

3.8.1. Final Set-Up and Test

To test the set-up and ensure that the adjustable frequency drive is running, follow these steps.

3

Step 1. Locate the motor nameplate



NOTE

The motor is either star- (Y) or delta-connected (Δ). This information is located on the motor nameplate data.

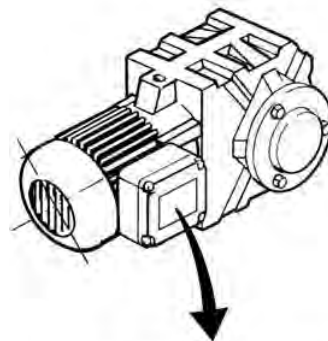

BAUER D-73734 ESLINGEN		
3~ MOTOR NR. 1827421 2003		
S/E005A9		
	1,5	kW
n_2	31,5	/min. 400 Y V
n_1	1400	/min. 50 Hz
$\cos \varphi$	0,80	3,6 A
1,7L		
B	IP 65	H1/1A

130BT307

Step 2. Enter the motor nameplate data in this parameter list.

To access this list, first press the [QUICK MENU] key, then select "Q2 Quick Set-up".

1.	Motor Power [kW] or Motor Power [HP]	par. 1-20 par. 1-21
2.	Motor Voltage	par. 1-22
3.	Motor Frequency	par. 1-23
4.	Motor Current	par. 1-24
5.	Motor Nominal Speed	par. 1-25

Step 3. Activate the Automatic Motor Adaptation (AMA)

Performing an AMA will ensure optimum performance. The AMA measures the values from the motor model equivalent diagram.

1. Connect terminal 37 to terminal 12 (if terminal 37 is available).
2. Connect terminal 27 to terminal 12, or set par. 5-12 to 'No function' (par. 5-12 [0]).
3. Activate the AMA par. 1-29.

4. Choose between complete or reduced AMA. If a sine-wave filter is mounted, run only the reduced AMA, or remove the sine-wave filter during the AMA procedure.
5. Press the [OK] key. The display shows "Press [Hand on] to start."
6. Press the [Hand on] key. A progress bar indicates if the AMA is in progress.

Stop the AMA during operation.

1. Press the [OFF] key. The adjustable frequency drive enters into alarm mode and the display shows that the AMA was terminated by the user.

Successful AMA

1. The display shows "Press [OK] to finish AMA."
2. Press the [OK] key to exit the AMA state.

Unsuccessful AMA

1. The adjustable frequency drive enters into alarm mode. A description of the alarm can be found in the *Warnings and Alarms* chapter.
2. "Report Value" in the [Alarm Log] shows the last measuring sequence carried out by the AMA before the adjustable frequency drive entered alarm mode. This number, along with the description of the alarm, will assist you in troubleshooting. If you contact Danfoss for service, make sure to mention the number and alarm description.

	<p>NOTE</p> <p>Unsuccessful AMA is often caused by incorrectly registered motor nameplate data or a difference that is too large between the motor power size and the adjustable frequency drivepower size.</p>
--	--

Step 4. Set speed limit and ramp time

Minimum Reference	par. 3-02
Maximum Reference	par. 3-03

3.12: Set up the desired limits for speed and ramp time.

Motor Speed Low Limit	par. 4-11 or 4-12
Motor Speed High Limit	par. 4-13 or 4-14

Ramp-up Time 1 [s]	par. 3-41
Ramp-down Time 1 [s]	par. 3-42

3.9. Additional Connections

3.9.1. Mechanical Brake Control

3

In hoisting/lowering applications, it is necessary to be able to control an electro-mechanical brake:

- Control the brake using any relay output or digital output (terminal 27 or 29).
- Keep the output closed (voltage-free) as long as the adjustable frequency drive is unable to 'support' the motor, such as when the load is too heavy, for example.
- Select *Mechanical brake control* [32] in par. 5-4* for applications with an electro-mechanical brake.
- The brake is released when the motor current exceeds the preset value found in par. 2-20.
- The brake is engaged when the output frequency is less than the frequency found in par. 2-21 or 2-22, and only if the adjustable frequency drive carries out a stop command.

If the adjustable frequency drive is in alarm mode or in an overvoltage situation, the mechanical brake immediately cuts in.

3.9.2. Parallel Connection of Motors

The adjustable frequency drive can control several parallel-connected motors. The total current consumption of the motors must not exceed the rated output current $I_{M,N}$ for the adjustable frequency drive.

NOTE
Installation with cables connected in a common joint, as in the illustration below, is only recommended for short cable lengths.

NOTE
When motors are connected in parallel, par. 1-29 *Automatic Motor Adaptation (AMA)* cannot be used.

NOTE
The electronic thermal relay (ETR) of the adjustable frequency drive cannot be used for motor protection for the individual motor of systems with parallel-connected motors. Provide further motor protection with, for example, thermistors in each motor or individual thermal relays (circuit breakers are not suitable for protection).

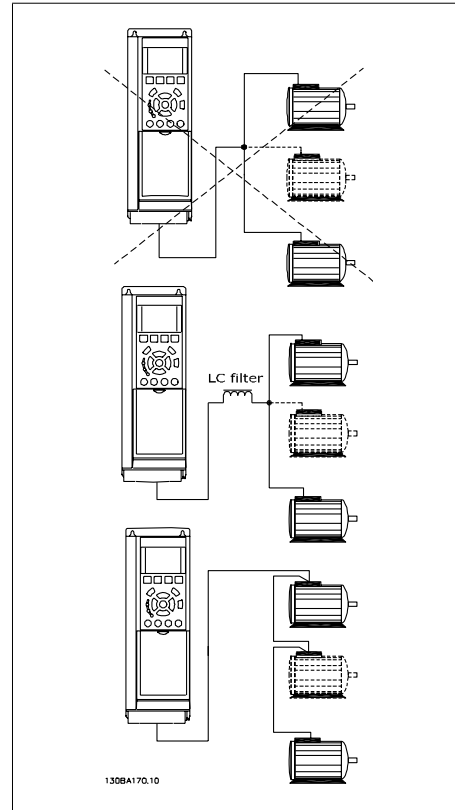

Problems may arise at start and at low RPM values if motor sizes are widely different because small motors' relatively high ohmic resistance in the stator calls for a higher voltage at start and at low RPM values.

3.9.3. Motor Thermal Protection

The electronic thermal relay in the adjustable frequency drive has received UL approval for single motor protection when par. 1-90 *Motor Thermal Protection* is set for *ETR Trip* and par. 1-24 *Motor current, $I_{M,N}$* is set to the rated motor current (see motor nameplate).

For thermal motor protection, it is also possible to use the MCB 112 PTC thermistor card option. This card provides an ATEX certificate to protect motors in explosion hazard areas, Zone 1/21 and Zone 2/22. Please refer to the *Design Guide* for further information.

4. How to Program

4.1. The Graphical and Numerical LCP

The easiest way to program the adjustable frequency drive is to use the Graphical Local Control Panel (LCP 102). It is necessary to consult the adjustable frequency drive Design Guide when using the Numeric Local Control Panel (LCP 101).

4.1.1. How to Program on the Graphical LCP

The following instructions are valid for the graphical LCP (LCP 102):

The control panel is divided into four functional groups:

1. Graphical display with status lines.
2. Menu keys and LEDs - changing parameters and switching between display functions.
3. Navigation keys and indicator lights (LEDs).
4. Operation keys and LEDs.

All data is displayed in a graphical LCP display, which can show up to five items of operating data while displaying [Status].

Display lines:

- a. **Status line:** Status messages displaying icons and graphics.¹
- b. **Line 1-2:** Operator data lines displaying data defined or chosen by the user. By pressing the [Status] key, up to one extra line can be added.¹
- c. **Status line:** Status messages displaying text.¹

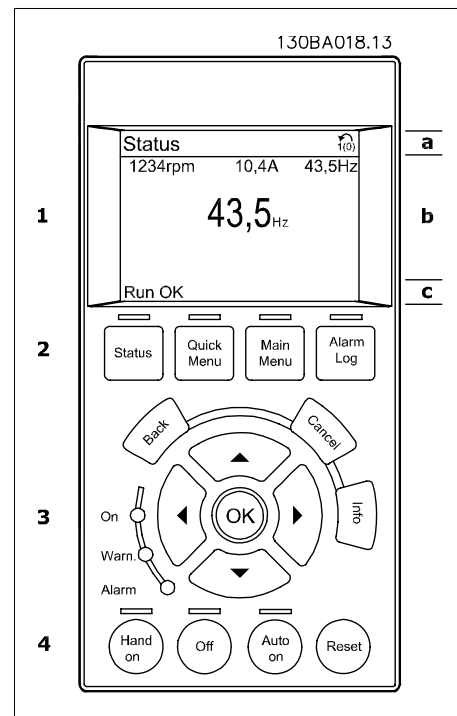

4.1.2. How to Program on the Numerical Local Control Panel

The following instructions are valid for the numerical LCP (LCP 101):

The control panel is divided into four functional groups:

1. Numerical display.
2. Menu keys and LEDs - changing parameters and switching between display functions.
3. Navigation keys and indicator lights (LEDs).
4. Operation keys and LEDs.

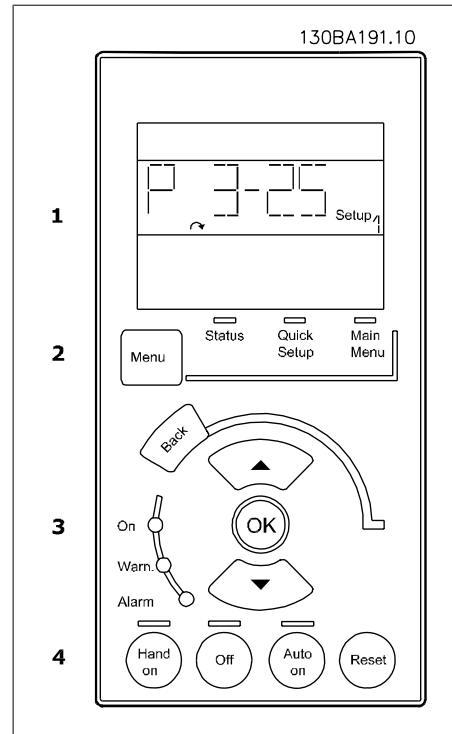

4.1.3. Initial Commissioning

The easiest way of carrying out the initial commissioning is by using the Quick Menu button and follow the quick set-up procedure using LCP 102 (read table from left to right):

Press			
		Q2 Quick Menu	
0-01 Language		Set language	
1-20 Motor power		Set motor nameplate power	
1-22 Motor voltage		Set nameplate voltage	
1-23 Motor frequency		Set nameplate frequency	
1-24 Motor current		Set nameplate current	
1-25 Motor nominal speed		Set nameplate speed in RPM	
5-12 Terminal 27 Digital Input		If terminal default is <i>Coast inverse</i> , it is possible to change this setting to <i>No function</i> . No connection to terminal 27 is then needed for running AMA	
1-29 Automatic Motor Adaptation		Set desired AMA function. Enabling complete AMA is recommended	
3-02 Minimum reference		Set the minimum speed of the motor shaft	
3-03 Maximum Reference		Set the maximum speed of the motor shaft	
3-41 Ramp1 up time		Set the ramping-up time with reference to the nominal motor speed (set in par. 1-25)	
3-42 Ramp1 down time		Set the ramping-down time with reference to the nominal motor speed (set in par. 1-25)	
3-13 Reference site		Set the site from where the reference must work	

4.2. Quick Setup

0-01 Language

Option:
Function:

Defines the language to be used in the display.

The adjustable frequency drive can be delivered with 4 different language packages. English and German are included in all packages. English cannot be erased or manipulated.

[0] *	English UK	Part of Language packages 1 - 4
[1]	German	Part of Language packages 1 - 4
[2]	French	Part of Language package 1
[3]	Danish	Part of Language package 1
[4]	Spanish	Part of Language package 1
[5]	Italian	Part of Language package 1
[6]	Swedish	Part of Language package 1
[7]	Dutch	Part of Language package 1
[10]	Chinese	Language package 2
[20]	Finnish	Part of Language package 1
[22]	English US	Part of Language package 4
[27]	Greek	Part of Language package 4
[28]	Portuguese	Part of Language package 4
[36]	Slovenian	Part of Language package 3
[39]	Korean	Part of Language package 2
[40]	Japanese	Part of Language package 2
[41]	Turkish	Part of Language package 4
[42]	Traditional Chinese	Part of Language package 2
[43]	Bulgarian	Part of Language package 3
[44]	Serbian	Part of Language package 3
[45]	Romanian	Part of Language package 3
[46]	Hungarian	Part of Language package 3
[47]	Czech	Part of Language package 3
[48]	Polish	Part of Language package 4
[49]	Russian	Part of Language package 3
[50]	Thai	Part of Language package 2

[51] Bahasa Indonesian Part of Language package 2

1-20 Motor Power

Range:
Size re- [0.12-1,600 hp
lated* [0.09-1,200 kW]]

Function:
Enter the nominal motor power (in kW) according to the motor nameplate data. The default value corresponds to the nominal rated output of the unit.
This parameter cannot be adjusted while the motor is running. This parameter is visible in LCP if par. 0-03 is *International* [0].

1-22 Motor Voltage

Range:
Size re- [10 - 1,000 V]
lated*

Function:
Enter the nominal motor voltage according to the motor nameplate data. The default value corresponds to the nominal rated output of the unit.
This parameter cannot be adjusted while the motor is running.

1-23 Motor Frequency

Option:

Function:
Min - Max motor frequency: 20 - 1,000 Hz
Select the motor frequency value from the motor nameplate data. If a value different from 50 Hz or 60 Hz is selected, it is necessary to adapt the load independent settings in par. 1-50 to 1-53. For 87 Hz operation with 230/400 V motors, set the nameplate data for 230 V/50 Hz. Adapt par. 4-13 *Motor Speed High Limit [RPM]* and par. 3-03 *Maximum Reference* to the 87 Hz application.

[50] * 50 Hz when parameter 0-03 = international

[60] 60 Hz when parameter 0-03 = US

1-24 Motor Current

Range:
Size re- [0.1 - 10,000 A]
lated*

Function:
Enter the nominal motor current value from the motor nameplate data. This data is used for calculating motor torque, motor thermal protection, etc.

This parameter cannot be adjusted while the motor is running.

1-25 Motor Nominal Speed

Range:

Size re- [100 - 60,000 rpm]
lated*

Function:

Enter the nominal motor speed value from the motor nameplate data. This data is used for calculating automatic motor compensations.

This parameter cannot be adjusted while the motor is running.

4

5-12 Terminal 27 Digital Input

Option:
Function:

Select the function from the available digital input range.

No operation	[0]
Reset	[1]
Coast inverse	[2]
Coast and reset inverse	[3]
Quick stop inverse	[4]
DC brake inverse	[5]
Stop inverse	[6]
Start	[8]
Latched start	[9]
Reversing	[10]
Start reverse	[11]
Enable start forward	[12]
Enable start reverse	[13]
Jog	[14]
Preset ref bit 0	[16]
Preset ref bit 1	[17]
Preset ref bit 2	[18]
Freeze reference	[19]
Freeze output	[20]
Speed up	[21]
Slow	[22]
Set-up select bit 0	[23]
Set-up select bit 1	[24]
Catch up	[28]
Slow-down	[29]
Pulse input	[32]
Ramp bit 0	[34]
Ramp bit 1	[35]
Line failure inverse	[36]
DigiPot Increase	[55]
DigiPot Decrease	[56]
DigiPot Clear	[57]
Reset Counter A	[62]
Reset Counter B	[65]

1-29 Automatic Motor Adaptation (AMA)

Option:

Function:

The AMA function optimizes dynamic motor performance by automatically optimizing the advanced motor parameters (par. 1-30 to par. 1-35) during motor standstill.

Activate the AMA function by pressing [Hand on] after selecting [1] or [2]. See also the section *Automatic Motor Adaptation*. After a normal sequence, the display will read: "Press [OK] to finish AMA". After pressing the [OK] key, the adjustable frequency drive is ready for operation.

This parameter cannot be adjusted while the motor is running.

[0] * OFF

[1] Enable complete AMA Performs AMA of the stator resistance R_s , the rotor resistance R_r , the stator leakage reactance X_1 , the rotor leakage reactance X_2 and the main reactance X_h . Select this option if an LC filter is used between the drive and the motor.

FC 301: The complete AMA does not include X_h measurement for the FC 301. Instead, the X_h value is determined from the motor database. Par. 1-35 *Main Reactance (X_h)* may be adjusted to obtain optimal start performance.

[2] Enable reduced AMA Performs a reduced AMA of the stator resistance R_s in the system only.

Note:

- For the best adaptation of the adjustable frequency drive, run the AMA on a cold motor.
- AMA cannot be performed while the motor is running.
- AMA cannot be performed on permanent magnet motors.



NOTE

It is important to set motor par. 1-2* Motor Data correctly, since these form part of the AMA algorithm. An AMA must be performed to achieve optimum dynamic motor performance. It may take up to 10 min, depending on the power rating of the motor.



NOTE

Avoid generating external torque during AMA.



NOTE

If one of the settings in par. 1-2* Motor Data is changed, par. 1-30 to 1-39, the advanced motor parameters will return to default setting.

3-02 Minimum Reference

Range: 0.000 [-100000.000 - par. Unit* 3-03]

Function: The *Minimum reference* is the minimum value obtained by the sum of all references. *Minimum reference* is only active if *Min - Max* [0] is set in par. 3-00.

3-03 Maximum Reference

Range: 1500.00 [Par. 3-02] - 0* 100000.000]

Function: Enter the maximum reference. The maximum reference is the highest value obtainable by adding all references together.

- The Maximum Reference unit matches:**
- The choice of configuration in par. 1-00 *Configuration Mode*: for *Speed closed-loop* [1], RPM; for *Torque* [2], Nm.
 - The unit selected in par. 3-01 *Reference/Feedback Unit*.

3-41 Ramp 1 Ramp-up Time

Range: s* [0.01 - 3600.00 s]

Function: Enter the ramp-up time, i.e., the acceleration time from 0 RPM to the rated motor speed $n_{M,N}$ (par. 1-25). Choose a ramp-up time such that the output current does not exceed the current limit in par. 4-18 during ramping. The value 0.00 corresponds to 0.01 sec. in speed mode. See ramp-down time in par. 3-42.

$$Par. 3 - 41 = \frac{t_{acc} [s] \times n_{M, N} (par. 1 - 25) [RPM]}{\Delta ref [RPM]}$$

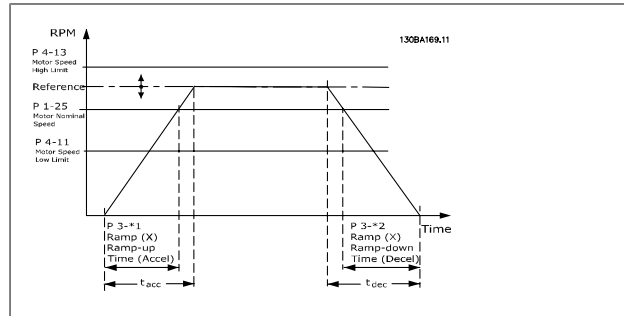

3-42 Ramp 1 Ramp-down Time

Range:
Size re- [0.01 - 3600.00 s]
lated

Function:
Enter the ramp-down time, i.e., the deceleration time from the rated motor speed $n_{M,N}$ (par. 1-25) to 0 RPM. Choose a ramp-down time so that no overvoltage arises in the inverter due to regenerative operation of the motor, and so that the generated current does not exceed the current limit set in par. 4-18. The value 0.00 corresponds to 0.01 s in speed mode. See ramp-up time in par. 3-41.

$$Par. 3 - 42 = \frac{t_{acc} [s] \times n_{M, N} (par. 1 - 25) [RPM]}{\Delta_{ref} [RPM]}$$

4.3. Parameter Lists

Changes during operation

"TRUE" means that the parameter can be changed while the adjustable frequency drive is in operation, and "FALSE" means that it must be stopped before a change can be made.

4-Set-up

'All set-up': the parameters can be set individually in each of the four set-ups, i.e., one single parameter can have four different data values.

'1 set-up': the data value will be the same in all set-ups.

Conversion index

This number refers to a conversion figure used when writing or reading to and from the adjustable frequency drive.

Conv. index	100	67	6	5	4	3	2	1	0	-1	-2	-3	-4	-5	-6
Conv. factor	1	1/60	100000 0	100000	10000	1000	100	10	1	0.1	0.01	0.00 1	0.000 1	0.0000 1	0.000001

Data type	Description	Type
2	Integer 8	Int8
3	Integer 16	Int16
4	Integer 32	Int32
5	Unsigned 8	UInt8
6	Unsigned 16	UInt16
7	Unsigned 32	UInt32
9	Visible String	VisStr
33	Normalized value 2 bytes	N2
35	Bit sequence of 16 Boolean variables	V2
54	Time difference w/o date	TimD

See the adjustable frequency drive *Design Guide* for further information about data types 33, 35 and 54.

Parameters for the adjustable frequency drive are grouped into various parameter groups for easy selection of the correct parameters for optimized operation of the adjustable frequency drive.

0-xx Operation and display parameters for basic adjustable frequency drive settings

1-xx Load and motor parameters, includes all load and motor-related parameters

- 2-xx Brake parameters
- 3-xx References and ramping parameters, includes DigiPot function
- 4-xx Limits warnings, setting of limits and warning parameters
- 5-xx Digital inputs and outputs, includes relay controls
- 6-xx Analog inputs and outputs
- 7-xx Controls, setting parameters for speed and process controls
- 8-xx Communication and option parameters, setting of FC RS485 and FC USB port parameters.
- 9-xx Profibus parameters
- 10-xx DeviceNet and CAN Serial Communication parameters
- 13-xx Smart Logic Control parameters
- 14-xx Special function parameters
- 15-xx Drive information parameters
- 16-xx Readout parameters
- 17-xx Encoder option parameters
- 32-xx MCO 305 Basic parameters
- 33-xx MCO 305 Advanced parameters
- 34-xx MCO Data Readout parameters

4.3.1. 0-** Operation/Display

Par. No. #	Parameter description	Default value	4-set-up	FC 302 only	Change during operation	Conversion index	Type
0-0* Basic Settings							
0-01	Language	[0] English	1 set-up		TRUE	-	Uint8
0-02	Motor Speed Unit	[0] RPM	2 set-ups		FALSE	-	Uint8
0-03	Regional Settings	[0] International	2 set-ups		FALSE	-	Uint8
0-04	Operating State at Power-up (Hand)	[1] Forced stop, ref=old	All set-ups		TRUE	-	Uint8
0-1* Set-up Operations							
0-10	Active Set-up	[1] Set-up 1	1 set-up		TRUE	-	Uint8
0-11	Edit Set-up	[1] Set-up 1	All set-ups		TRUE	-	Uint8
0-12	This Set-up Linked to	[0] Not linked	All set-ups		FALSE	-	Uint8
0-13	Readout: Linked Set-ups	0 N/A	All set-ups		FALSE	0	Uint16
0-14	Readout: Edit Set-ups / Channel	0 N/A	All set-ups		TRUE	0	Int32
0-2* LCP Display							
0-20	Display Line 1.1 Small	1617	All set-ups		TRUE	-	Uint16
0-21	Display Line 1.2 Small	1614	All set-ups		TRUE	-	Uint16
0-22	Display Line 1.3 Small	1610	All set-ups		TRUE	-	Uint16
0-23	Display Line 2 Large	1613	All set-ups		TRUE	-	Uint16
0-24	Display Line 3 Large	1602	All set-ups		TRUE	-	Uint16
0-25	My Personal Menu	ExpressionLimit	1 set-up		TRUE	0	Uint16
0-3* LCP Cust. Readout							
0-30	Unit for User-defined Readout	[0] None	All set-ups		TRUE	-	Uint8
0-31	Min Value of User-defined Readout	0.00 CustomReadoutUnit	All set-ups		TRUE	-2	Int32
0-32	Max Value of User-defined Readout	100.00 CustomReadoutUnit	All set-ups		TRUE	-2	Int32
0-4* LCP Keypad							
0-40	[Hand on] Key on LCP	[1] Enabled	All set-ups		TRUE	-	Uint8
0-41	[Off] Key on LCP	[1] Enabled	All set-ups		TRUE	-	Uint8
0-42	[Auto on] Key on LCP	[1] Enabled	All set-ups		TRUE	-	Uint8
0-43	[Reset] Key on LCP	[1] Enabled	All set-ups		TRUE	-	Uint8
0-5* Copy/Save							
0-50	LCP Copy	[0] No copy	All set-ups		FALSE	-	Uint8
0-51	Set-up Copy	[0] No copy	All set-ups		FALSE	-	Uint8
0-6* Password							
0-60	Main Menu Password	100 N/A	1 set-up		TRUE	0	Int16
0-61	Access to Main Menu w/o Password	[0] Full access	1 set-up		TRUE	-	Uint8
0-65	Quick Menu Password	200 N/A	1 set-up		TRUE	0	Int16
0-66	Access to Quick Menu w/o Password	[0] Full access	1 set-up		TRUE	-	Uint8
0-67	Bus Password Access	0 N/A	All set-ups		TRUE	0	Uint16

4.3.2. 1-**- Load/Motor

Par. No. #	Parameter description	Default value	4-set-up	FC 302 only	Change during operation	Conversion index	Type
1-0* General Settings							
1-00	Configuration Mode	null	All set-ups		TRUE	-	Uint8
1-01	Motor Control Principle	null	All set-ups		FALSE	-	Uint8
1-02	Flux Motor Feedback Source	[1] 24V encoder	All set-ups	x	FALSE	-	Uint8
1-03	Torque Characteristics	[0] Constant torque	All set-ups		TRUE	-	Uint8
1-04	Overload Mode	[0] High torque	All set-ups		FALSE	-	Uint8
1-05	Local Mode Configuration	[2] As mode par 1-00	All set-ups		TRUE	-	Uint8
1-1* Motor Selection							
1-10	Motor Construction	[0] Asynchron	All set-ups		FALSE	-	Uint8
1-2* Motor Data							
1-20	Motor Power [kW]	ExpressionLimit	All set-ups		FALSE	1	Uint32
1-21	Motor Power [HP]	ExpressionLimit	All set-ups		FALSE	-2	Uint32
1-22	Motor Voltage	ExpressionLimit	All set-ups		FALSE	0	Uint16
1-23	Motor Frequency	ExpressionLimit	All set-ups		FALSE	0	Uint16
1-24	Motor Current	ExpressionLimit	All set-ups		FALSE	-2	Uint32
1-25	Motor Nominal Speed	ExpressionLimit	All set-ups		FALSE	67	Uint16
1-26	Motor Cont. Rated Torque	ExpressionLimit	All set-ups		FALSE	-1	Uint32
1-29	Automatic Motor Adaptation (AMA)	[0] Off	All set-ups		FALSE	-	Uint8
1-3* Addl. Motor Data							
1-30	Stator Resistance (Rs)	ExpressionLimit	All set-ups		FALSE	-4	Uint32
1-31	Rotor Resistance (Rr)	ExpressionLimit	All set-ups		FALSE	-4	Uint32
1-33	Stator Leakage Reactance (X1)	ExpressionLimit	All set-ups		FALSE	-4	Uint32
1-34	Rotor Leakage Reactance (X2)	ExpressionLimit	All set-ups		FALSE	-4	Uint32
1-35	Main Reactance (Xh)	ExpressionLimit	All set-ups		FALSE	-4	Uint32
1-36	Iron Loss Resistance (Rfe)	ExpressionLimit	All set-ups		FALSE	-3	Uint32
1-37	d-axis Inductance (Ld)	ExpressionLimit	All set-ups	x	FALSE	-4	Int32
1-39	Motor Poles	ExpressionLimit	All set-ups		FALSE	0	Uint8
1-40	Back EMF at 1000 RPM	ExpressionLimit	All set-ups	x	FALSE	0	Uint16
1-41	Motor Angle Offset	0 N/A	All set-ups		FALSE	0	Int16
1-5* Load-Indep. Setting							
1-50	Motor Magnetization at Zero Speed	100 %	All set-ups		TRUE	0	Uint16
1-51	Min Speed Normal Magnetizing [RPM]	ExpressionLimit	All set-ups		TRUE	67	Uint16
1-52	Min Speed Normal Magnetizing [Hz]	ExpressionLimit	All set-ups		TRUE	-1	Uint16
1-53	Model Shift Frequency	ExpressionLimit	All set-ups	x	FALSE	-1	Uint16
1-55	U/f Characteristic - U	ExpressionLimit	All set-ups		TRUE	-1	Uint16
1-56	U/f Characteristic - F	ExpressionLimit	All set-ups		TRUE	-1	Uint16

Par. No. #	Parameter description	Default value	4-set-up	FC 302 only	Change during operation	Conversion index	Type
1-6* Load-Depend. Settg.							
1-60	Low Speed Load Compensation	100 %	All set-ups		TRUE	0	Int16
1-61	High Speed Load Compensation	100 %	All set-ups		TRUE	0	Int16
1-62	Slip Compensation	ExpressionLimit	All set-ups		TRUE	0	Int16
1-63	Slip Compensation Time Constant	ExpressionLimit	All set-ups		TRUE	-2	Uint16
1-64	Resonance Dampening	100 %	All set-ups		TRUE	0	Uint16
1-65	Resonance Dampening Time Constant	5 ms	All set-ups		TRUE	-3	Uint8
1-66	Min. Current at Low Speed	100 %	All set-ups	x	TRUE	0	Uint8
1-67	Load Type	[0] Passive load	All set-ups	x	TRUE	-	Uint8
1-68	Minimum Inertia	ExpressionLimit	All set-ups	x	FALSE	-4	Uint32
1-69	Maximum Inertia	ExpressionLimit	All set-ups	x	FALSE	-4	Uint32
1-7* Start Adjustments							
1-71	Start Delay	0.0 s	All set-ups		TRUE	-1	Uint8
1-72	Start Function	[2] Coast/delay time	All set-ups		TRUE	-	Uint8
1-73	Flying Start	[0] Disabled	All set-ups		FALSE	-	Uint8
1-74	Start Speed [RPM]	ExpressionLimit	All set-ups		TRUE	67	Uint16
1-75	Start Speed [Hz]	ExpressionLimit	All set-ups		TRUE	-1	Uint16
1-76	Start Current	0.00 A	All set-ups		TRUE	-2	Uint32
1-8* Stop Adjustments							
1-80	Function at Stop	[0] Coast	All set-ups		TRUE	-	Uint8
1-81	Min Speed for Function at Stop [RPM]	ExpressionLimit	All set-ups		TRUE	67	Uint16
1-82	Min Speed for Function at Stop [Hz]	ExpressionLimit	All set-ups		TRUE	-1	Uint16
1-83	Precise Stop Function	[0] Precise ramp stop	All set-ups		FALSE	-	Uint8
1-84	Precise Stop Counter Value	100000 N/A	All set-ups		TRUE	0	Uint32
1-85	Precise Stop Speed Compensation Delay	10 ms	All set-ups		TRUE	-3	Uint8
1-9* Motor Temperature							
1-90	Motor Thermal Protection	[0] No protection	All set-ups		TRUE	-	Uint8
1-91	Motor External Fan	[0] No	All set-ups		TRUE	-	Uint16
1-93	Thermistor Resource	[0] None	All set-ups		TRUE	-	Uint8
1-95	KTY Sensor Type	[0] KTY Sensor 1	All set-ups	x	TRUE	-	Uint8
1-96	KTY Thermistor Resource	[0] None	All set-ups	x	TRUE	-	Uint8
1-97	KTY Threshold level	80 °C	1 set-up	x	TRUE	100	Int16

4.3.3. 2-** Brakes

Par. No. #	Parameter description	Default value	4-set-up	FC 302 only	Change during operation	Conversion index	Type
2-0* DC Brake							
2-00	DC Hold Current	50 %	All set-ups		TRUE	0	Uint8
2-01	DC Brake Current	50 %	All set-ups		TRUE	0	Uint16
2-02	DC Braking Time	10.0 s	All set-ups		TRUE	-1	Uint16
2-03	DC Brake Cut-in Speed [RPM]	ExpressionLimit	All set-ups		TRUE	67	Uint16
2-04	DC Brake Cut-in Speed [Hz]	ExpressionLimit	All set-ups		TRUE	-1	Uint16
2-1* Brake Energy Funct.							
2-10	Brake Function	null	All set-ups		TRUE	-	Uint8
2-11	Brake Resistor (ohm)	ExpressionLimit	All set-ups		TRUE	-2	Uint32
2-12	Brake Power Limit (kW)	ExpressionLimit	All set-ups		TRUE	0	Uint32
2-13	Brake Power Monitoring	[0] Off	All set-ups		TRUE	-	Uint8
2-15	Brake Check	[0] Off	All set-ups		TRUE	-	Uint8
2-16	AC Brake Max. Current	100.0 %	All set-ups		TRUE	-1	Uint32
2-17	Over-voltage Control	[0] Disabled	All set-ups		TRUE	-	Uint8
2-2* Mechanical Brake							
2-20	Release Brake Current	ImaxVLT (P1637)	All set-ups		TRUE	-2	Uint32
2-21	Activate Brake Speed [RPM]	ExpressionLimit	All set-ups		TRUE	67	Uint16
2-22	Activate Brake Speed [Hz]	ExpressionLimit	All set-ups		TRUE	-1	Uint16
2-23	Activate Brake Delay	0.0 s	All set-ups		TRUE	-1	Uint8
2-24	Stop Delay	0.0 s	All set-ups		TRUE	-1	Uint8
2-25	Brake Release Time	0.20 s	All set-ups		TRUE	-2	Uint16
2-26	Torque Ref	0.00 %	All set-ups		TRUE	-2	Int16
2-27	Torque Ramp Time	0.2 s	All set-ups		TRUE	-1	Uint8
2-28	Gain Boost Factor	1.00 N/A	All set-ups		TRUE	-2	Uint16

4.3.4. 3-** Reference / Ramps

Par. No. #	Parameter description	Default value	4-set-up	FC 302 only	Change during operation	Conversion index	Type
3-0* Reference Limits							
3-00	Reference Range	null	All set-ups		TRUE	-	Uint8
3-01	Reference/Feedback Unit	null	All set-ups		TRUE	-	Uint8
3-02	Minimum Reference	0 ReferenceFeedbackUnit	All set-ups		TRUE	-3	Int32
3-03	Maximum Reference	ExpressionLimit	All set-ups		TRUE	-3	Int32
3-04	Reference Function	[0] Sum	All set-ups		TRUE	-	Uint8
3-1* References							
3-10	Preset Reference	0.00 %	All set-ups		TRUE	-2	Int16
3-11	Jog Speed [Hz]	ExpressionLimit	All set-ups		TRUE	-1	Uint16
3-12	Catch up/slow-down Value	0.00 %	All set-ups		TRUE	-2	Int16
3-13	Reference Site	[0] Linked to Hand / Auto	All set-ups		TRUE	-	Uint8
3-14	Preset Relative Reference	0.00 %	All set-ups		TRUE	-2	Int32
3-15	Reference Resource 1	null	All set-ups		TRUE	-	Uint8
3-16	Reference Resource 2	null	All set-ups		TRUE	-	Uint8
3-17	Reference Resource 3	null	All set-ups		TRUE	-	Uint8
3-18	Relative Scaling Reference Resource	[0] No function	All set-ups		TRUE	-	Uint8
3-19	Jog Speed [RPM]	ExpressionLimit	All set-ups		TRUE	67	Uint16
3-4* Ramp 1							
3-40	Ramp 1 Type	[0] Linear	All set-ups		TRUE	-	Uint8
3-41	Ramp 1 Ramp-up Time	ExpressionLimit	All set-ups		TRUE	-2	Uint32
3-42	Ramp 1 Ramp-down Time	ExpressionLimit	All set-ups		TRUE	-2	Uint32
3-45	Ramp 1 S-ramp Ratio at Accel. Start	50 %	All set-ups		TRUE	0	Uint8
3-46	Ramp 1 S-ramp Ratio at Accel. End	50 %	All set-ups		TRUE	0	Uint8
3-47	Ramp 1 S-ramp Ratio at Decel. Start	50 %	All set-ups		TRUE	0	Uint8
3-48	Ramp 1 S-ramp Ratio at Decel. End	50 %	All set-ups		TRUE	0	Uint8
3-5* Ramp 2							
3-50	Ramp 2 Type	[0] Linear	All set-ups		TRUE	-	Uint8
3-51	Ramp 2 Ramp-up Time	ExpressionLimit	All set-ups		TRUE	-2	Uint32
3-52	Ramp 2 Ramp-down Time	ExpressionLimit	All set-ups		TRUE	-2	Uint32
3-55	Ramp 2 S-ramp Ratio at Accel. Start	50 %	All set-ups		TRUE	0	Uint8
3-56	Ramp 2 S-ramp Ratio at Accel. End	50 %	All set-ups		TRUE	0	Uint8
3-57	Ramp 2 S-ramp Ratio at Decel. Start	50 %	All set-ups		TRUE	0	Uint8
3-58	Ramp 2 S-ramp Ratio at Decel. End	50 %	All set-ups		TRUE	0	Uint8

Par. No. #	Parameter description	Default value	4 set-up	FC 302 only	Change during operation	Conver- sion index	Type
3-6* Ramp 3							
3-60	Ramp 3 Type	[0] Linear	All set-ups		TRUE	-	Uint8
3-61	Ramp 3 Ramp-up Time	ExpressionLimit	All set-ups		TRUE	-2	Uint32
3-62	Ramp 3 Ramp-down Time	ExpressionLimit	All set-ups		TRUE	-2	Uint32
3-65	Ramp 3 S-ramp Ratio at Accel. Start	50 %	All set-ups		TRUE	0	Uint8
3-66	Ramp 3 S-ramp Ratio at Accel. End	50 %	All set-ups		TRUE	0	Uint8
3-67	Ramp 3 S-ramp Ratio at Decel. Start	50 %	All set-ups		TRUE	0	Uint8
3-68	Ramp 3 S-ramp Ratio at Decel. End	50 %	All set-ups		TRUE	0	Uint8
3-7* Ramp 4							
3-70	Ramp 4 Type	[0] Linear	All set-ups		TRUE	-	Uint8
3-71	Ramp 4 Ramp-up Time	ExpressionLimit	All set-ups		TRUE	-2	Uint32
3-72	Ramp 4 Ramp-down Time	ExpressionLimit	All set-ups		TRUE	-2	Uint32
3-75	Ramp 4 S-ramp Ratio at Accel. Start	50 %	All set-ups		TRUE	0	Uint8
3-76	Ramp 4 S-ramp Ratio at Accel. End	50 %	All set-ups		TRUE	0	Uint8
3-77	Ramp 4 S-ramp Ratio at Decel. Start	50 %	All set-ups		TRUE	0	Uint8
3-78	Ramp 4 S-ramp Ratio at Decel. End	50 %	All set-ups		TRUE	0	Uint8
3-8* Other Ramps							
3-80	Jog Ramp Time	ExpressionLimit	All set-ups		TRUE	-2	Uint32
3-81	Quick Stop Ramp Time	ExpressionLimit	2 set-ups		TRUE	-2	Uint32
3-9* Digital Potentiometer							
3-90	Step Size	0.10 %	All set-ups		TRUE	-2	Uint16
3-91	Ramp Time	1.00 s	All set-ups		TRUE	-2	Uint32
3-92	Power Restore	[0] Off	All set-ups		TRUE	-	Uint8
3-93	Maximum Limit	100 %	All set-ups		TRUE	0	Int16
3-94	Minimum Limit	-100 %	All set-ups		TRUE	0	Int16
3-95	Ramp Delay	1.000 N/A	All set-ups		TRUE	-3	TimD

4.3.5. 4-** Limits / Warnings

Par. No. #	Parameter description	Default value	4-set-up	FC 302 only	Change during operation	Conversion index	Type
4-1* Motor Limits							
4-10	Motor Speed Direction	null	All set-ups		FALSE	-	Uint8
4-11	Motor Speed Low Limit [RPM]	ExpressionLimit	All set-ups		TRUE	67	Uint16
4-12	Motor Speed Low Limit [Hz]	ExpressionLimit	All set-ups		TRUE	-1	Uint16
4-13	Motor Speed High Limit [RPM]	ExpressionLimit	All set-ups		TRUE	67	Uint16
4-14	Motor Speed High Limit [Hz]	ExpressionLimit	All set-ups		TRUE	-1	Uint16
4-16	Torque Limit Motor Mode	ExpressionLimit	All set-ups		TRUE	-1	Uint16
4-17	Torque Limit Generator Mode	100.0 %	All set-ups		TRUE	-1	Uint16
4-18	Current Limit	ExpressionLimit	All set-ups		TRUE	-1	Uint32
4-19	Max Output Frequency	132.0 Hz	All set-ups		FALSE	-1	Uint16
4-2* Limit Factors							
4-20	Torque Limit Factor Source	[0] No function	All set-ups		TRUE	-	Uint8
4-21	Speed Limit Factor Source	[0] No function	All set-ups		TRUE	-	Uint8
4-3* Motor Fb Monitor							
4-30	Motor Feedback Loss Function	[2] Trip	All set-ups		TRUE	-	Uint8
4-31	Motor Feedback Speed Error	300 RPM	All set-ups		TRUE	67	Uint16
4-32	Motor Feedback Loss Timeout	0.05 s	All set-ups		TRUE	-2	Uint16
4-5* Adj. Warnings							
4-50	Warning Current Low	0.00 A	All set-ups		TRUE	-2	Uint32
4-51	Warning Current High	ImaxVLT (P1637)	All set-ups		TRUE	-2	Uint32
4-52	Warning Speed Low	0 RPM	All set-ups		TRUE	67	Uint16
4-53	Warning Speed High	outputSpeedHighLimit (P413)	All set-ups		TRUE	67	Uint16
4-54	Warning Reference Low	-999999.999 N/A	All set-ups		TRUE	-3	Int32
4-55	Warning Reference High	999999.999 N/A	All set-ups		TRUE	-3	Int32
4-56	Warning Feedback Low	-999999.999 ReferenceFeedbackUnit	All set-ups		TRUE	-3	Int32
4-57	Warning Feedback High	999999.999 ReferenceFeedbackUnit	All set-ups		TRUE	-3	Int32
4-58	Missing Motor Phase Function	[1] On	All set-ups		TRUE	-	Uint8
4-6* Speed Bypass							
4-60	Bypass Speed From [RPM]	ExpressionLimit	All set-ups		TRUE	67	Uint16
4-61	Bypass Speed From [Hz]	ExpressionLimit	All set-ups		TRUE	-1	Uint16
4-62	Bypass Speed To [RPM]	ExpressionLimit	All set-ups		TRUE	67	Uint16
4-63	Bypass Speed To [Hz]	ExpressionLimit	All set-ups		TRUE	-1	Uint16

4.3.6. 5-** Digital In/Out

Par. No. #	Parameter description	Default value	4-set-up	FC 302 only	Change during operation	Conversion index	Type
5-0* Digital I/O mode							
5-00	Digital I/O Mode	[0] PNP	All set-ups		FALSE	-	Uint8
5-01	Terminal 27 Mode	[0] Input	All set-ups		TRUE	-	Uint8
5-02	Terminal 29 Mode	[0] Input	All set-ups	x	TRUE	-	Uint8
5-1* Digital Inputs							
5-10	Terminal 18 Digital Input	null	All set-ups		TRUE	-	Uint8
5-11	Terminal 19 Digital Input	null	All set-ups		TRUE	-	Uint8
5-12	Terminal 27 Digital Input	null	All set-ups		TRUE	-	Uint8
5-13	Terminal 29 Digital Input	null	All set-ups	x	TRUE	-	Uint8
5-14	Terminal 32 Digital Input	[0] No operation	All set-ups		TRUE	-	Uint8
5-15	Terminal 33 Digital Input	[0] No operation	All set-ups		TRUE	-	Uint8
5-16	Terminal X30/2 Digital Input	[0] No operation	All set-ups		TRUE	-	Uint8
5-17	Terminal X30/3 Digital Input	[0] No operation	All set-ups		TRUE	-	Uint8
5-18	Terminal X30/4 Digital Input	[0] No operation	All set-ups		TRUE	-	Uint8
5-19	Terminal 37 Safe Stop	[1] Safe Stop Alarm	1 set-up	x	TRUE	-	Uint8
5-3* Digital Outputs							
5-30	Terminal 27 Digital Output	null	All set-ups		TRUE	-	Uint8
5-31	Terminal 29 digital Output	null	All set-ups	x	TRUE	-	Uint8
5-32	Term X30/6 Digi Out (MCB 101)	null	All set-ups		TRUE	-	Uint8
5-33	Term X30/7 Digi Out (MCB 101)	null	All set-ups		TRUE	-	Uint8
5-4* Relays							
5-40	Function Relay	null	All set-ups		TRUE	-	Uint8
5-41	On Delay, Relay	0.01 s	All set-ups		TRUE	-2	Uint16
5-42	Off Delay, Relay	0.01 s	All set-ups		TRUE	-2	Uint16
5-5* Pulse Input							
5-50	Term. 29 Low Frequency	100 Hz	All set-ups	x	TRUE	0	Uint32
5-51	Term. 29 High Frequency	100 Hz	All set-ups	x	TRUE	0	Uint32
5-52	Term. 29 Low Ref./Feedb. Value	0.000 ReferenceFeedBackUnit	All set-ups	x	TRUE	-3	Int32
5-53	Term. 29 High Ref./Feedb. Value	ExpressionLimit	All set-ups	x	TRUE	-3	Int32
5-54	Pulse Filter Time Constant #29	100 ms	All set-ups	x	FALSE	-3	Uint16
5-55	Term. 33 Low Frequency	100 Hz	All set-ups		TRUE	0	Uint32
5-56	Term. 33 High Frequency	100 Hz	All set-ups		TRUE	0	Uint32
5-57	Term. 33 Low Ref./Feedb. Value	0.000 ReferenceFeedBackUnit	All set-ups		TRUE	-3	Int32
5-58	Term. 33 High Ref./Feedb. Value	ExpressionLimit	All set-ups		TRUE	-3	Int32
5-59	Pulse Filter Time Constant #33	100 ms	All set-ups		FALSE	-3	Uint16

Par. No. #	Parameter description	Default value	4-set-up	FC 302 only	Change during operation	Conver- sion index	Type
5-6* Pulse Output							
5-60	Terminal 27 Pulse Output Variable	null	All set-ups		TRUE	-	Uint8
5-62	Pulse Output Max Freq #27	ExpressionLimit	All set-ups		TRUE	0	Uint32
5-63	Terminal 29 Pulse Output Variable	null	All set-ups	x	TRUE	-	Uint8
5-65	Pulse Output Max Freq #29	ExpressionLimit	All set-ups	x	TRUE	0	Uint32
5-66	Terminal X30/6 Pulse Output Variable	null	All set-ups		TRUE	-	Uint8
5-68	Pulse Output Max Freq #X30/6	ExpressionLimit	All set-ups		TRUE	0	Uint32
5-7* 24V Encoder Input							
5-70	Term 32/33 Pulses per Revolution	1024 N/A	All set-ups		FALSE	0	Uint16
5-71	Term 32/33 Encoder Direction	[0] Clockwise	All set-ups		FALSE	-	Uint8
5-9* Bus Controlled							
5-90	Digital & Relay Bus Control	0 N/A	All set-ups		TRUE	0	Uint32
5-93	Pulse Out #27 Bus Control	0.00 %	All set-ups		TRUE	-2	N2
5-94	Pulse Out #27 Timeout Preset	0.00 %	1 set-up		TRUE	-2	Uint16
5-95	Pulse Out #29 Bus Control	0.00 %	All set-ups	x	TRUE	-2	N2
5-96	Pulse Out #29 Timeout Preset	0.00 %	1 set-up	x	TRUE	-2	Uint16

4.3.7. 6-**- Analog In/Out

Par. No. #	Parameter description	Default value	4-set-up	FC 302 only	Change during operation	Conversion index	Type
6-0* Analog I/O Mode							
6-00	Live Zero Timeout Time	10 s	All set-ups		TRUE	0	Uint8
6-01	Live Zero Timeout Function	[0] Off	All set-ups		TRUE	-	Uint8
6-1* Analog Input 1							
6-10	Terminal 53 Low Voltage	0.07 V	All set-ups		TRUE	-2	Int16
6-11	Terminal 53 High Voltage	10.00 V	All set-ups		TRUE	-2	Int16
6-12	Terminal 53 Low Current	0.14 mA	All set-ups		TRUE	-5	Int16
6-13	Terminal 53 High Current	20.00 mA	All set-ups		TRUE	-5	Int16
6-14	Terminal 53 Low Ref./Feedb. Value	0 ReferenceFeedbUnit	All set-ups		TRUE	-3	Int32
6-15	Terminal 53 High Ref./Feedb. Value	ExpressionLimit	All set-ups		TRUE	-3	Int32
6-16	Terminal 53 Filter Time Constant	0.001 s	All set-ups		TRUE	-3	Uint16
6-2* Analog Input 2							
6-20	Terminal 54 Low Voltage	0.07 V	All set-ups		TRUE	-2	Int16
6-21	Terminal 54 High Voltage	10.00 V	All set-ups		TRUE	-2	Int16
6-22	Terminal 54 Low Current	0.14 mA	All set-ups		TRUE	-5	Int16
6-23	Terminal 54 High Current	20.00 mA	All set-ups		TRUE	-5	Int16
6-24	Terminal 54 Low Ref./Feedb. Value	0 ReferenceFeedbUnit	All set-ups		TRUE	-3	Int32
6-25	Terminal 54 High Ref./Feedb. Value	ExpressionLimit	All set-ups		TRUE	-3	Int32
6-26	Terminal 54 Filter Time Constant	0.001 s	All set-ups		TRUE	-3	Uint16
6-3* Analog Input 53							
6-30	Terminal X30/11 Low Voltage	0.07 V	All set-ups		TRUE	-2	Int16
6-31	Terminal X30/11 High Voltage	10.00 V	All set-ups		TRUE	-2	Int16
6-34	Term. X30/11 Low Ref./Feedb. Value	0 ReferenceFeedbUnit	All set-ups		TRUE	-3	Int32
6-35	Term. X30/11 High Ref./Feedb. Value	ExpressionLimit	All set-ups		TRUE	-3	Int32
6-36	Term. X30/11 Filter Time Constant	0.001 s	All set-ups		TRUE	-3	Uint16
6-4* Analog Input 4							
6-40	Terminal X30/12 Low Voltage	0.07 V	All set-ups		TRUE	-2	Int16
6-41	Terminal X30/12 High Voltage	10.00 V	All set-ups		TRUE	-2	Int16
6-44	Term. X30/12 Low Ref./Feedb. Value	0 ReferenceFeedbUnit	All set-ups		TRUE	-3	Int32
6-45	Term. X30/12 High Ref./Feedb. Value	ExpressionLimit	All set-ups		TRUE	-3	Int32
6-46	Term. X30/12 Filter Time Constant	0.001 s	All set-ups		TRUE	-3	Uint16
6-5* Analog Output 1							
6-50	Terminal 42 Output	null	All set-ups		TRUE	-	Uint8
6-51	Terminal 42 Output Min Scale	0.00 %	All set-ups		TRUE	-2	Int16
6-52	Terminal 42 Output Max Scale	100.00 %	All set-ups		TRUE	-2	Int16
6-53	Terminal 42 Output Bus Control	0.00 %	All set-ups		TRUE	-2	N2
6-54	Terminal 42 Output Timeout Preset	0.00 %	1 set-up		TRUE	-2	Uint16
6-6* Analog Output 2							
6-60	Terminal X30/8 Output	null	All set-ups		TRUE	-	Uint8
6-61	Terminal X30/8 Min. Scale	0.00 %	All set-ups		TRUE	-2	Int16
6-62	Terminal X30/8 Max. Scale	100.00 %	All set-ups		TRUE	-2	Int16

4.3.8. 7-**-** Controllers

Par. No. #	Parameter description	Default value	4-set-up	FC 302 only	Change during operation	Conver- sion index	Type
7-0* Speed PID Ctrl.							
7-00	Speed PID Feedback Source	null	All set-ups		FALSE	-	Uint8
7-02	Speed PID Proportional Gain	ExpressionLimit	All set-ups		TRUE	-3	Uint16
7-03	Speed PID Integral Time	ExpressionLimit	All set-ups		TRUE	-4	Uint32
7-04	Speed PID Differentiation Time	ExpressionLimit	All set-ups		TRUE	-4	Uint16
7-05	Speed PID Diff. Gain Limit	5.0 N/A	All set-ups		TRUE	-1	Uint16
7-06	Speed PID Lowpass Filter Time	10.0 ms	All set-ups		TRUE	-4	Uint16
7-08	Speed PID Feed Forward Factor	0 %	All set-ups		FALSE	0	Uint16
7-2* Process Ctrl. Feedb							
7-20	Process CL Feedback 1 Resource	[0] No function	All set-ups		TRUE	-	Uint8
7-22	Process CL Feedback 2 Resource	[0] No function	All set-ups		TRUE	-	Uint8
7-3* Process PID Ctrl.							
7-30	Process PID Normal/Inverse Control	[0] Normal	All set-ups		TRUE	-	Uint8
7-31	Process PID Anti Windup	[1] On	All set-ups		TRUE	-	Uint8
7-32	Process PID Controller Start Value	0 RPM	All set-ups		TRUE	67	Uint16
7-33	Process PID Proportional Gain	0.01 N/A	All set-ups		TRUE	-2	Uint16
7-34	Process PID Integral Time	10000.00 s	All set-ups		TRUE	-2	Uint32
7-35	Process PID Differentiation Time	0.00 s	All set-ups		TRUE	-2	Uint16
7-36	Process PID Differentiation Gain Limit	5.0 N/A	All set-ups		TRUE	-1	Uint16
7-38	Process PID Feed Forward Factor	0 %	All set-ups		TRUE	0	Uint16
7-39	On Reference Bandwidth	5 %	All set-ups		TRUE	0	Uint8

4.3.9. 8-**- Comm. and Options

Par. No. #	Parameter description	Default value	4-set-up	FC 302 only	Change during operation	Conversion index	Type
8-0* General Settings							
8-01	Control Site	[0] Digital and ctrl. word null	All set-ups		TRUE	-	Uint8
8-02	Control Word Source	[0] Digital and ctrl. word null	All set-ups		TRUE	-	Uint8
8-03	Control Word Timeout Time	1.0 s	1 set-up		TRUE	-1	Uint32
8-04	Control Word Timeout Function	[0] Off	1 set-up		TRUE	-	Uint8
8-05	End-of-Timeout Function	[1] Resume set-up	1 set-up		TRUE	-	Uint8
8-06	Reset Control Word Timeout	[0] Do not reset	All set-ups		TRUE	-	Uint8
8-07	Diagnosis Trigger	[0] Disable	2 set-ups		TRUE	-	Uint8
8-1* Ctrl. Word Settings							
8-10	Control Word Profile	[0] FC profile	All set-ups		TRUE	-	Uint8
8-13	Configurable Status Word STW	[1] Profile Default	All set-ups		TRUE	-	Uint8
8-3* FC Port Settings							
8-30	Protocol	[0] FC	1 set-up		TRUE	-	Uint8
8-31	Address	1 N/A	1 set-up		TRUE	0	Uint8
8-32	FC Port Baud Rate	[2] 9600 Baud	1 set-up		TRUE	-	Uint8
8-35	Minimum Response Delay	10 ms	All set-ups		TRUE	-3	Uint16
8-36	Max Response Delay	5000 ms	1 set-up		TRUE	-3	Uint16
8-37	Max Inter-Char Delay	25 ms	1 set-up		TRUE	-3	Uint16
8-4* FC MC protocol set							
8-40	Telegram selection	[1] Standard telegram 1	2 set-ups		TRUE	-	Uint8
8-5* Digital/Bus							
8-50	Coasting Select	[3] Logic OR	All set-ups		TRUE	-	Uint8
8-51	Quick Stop Select	[3] Logic OR	All set-ups		TRUE	-	Uint8
8-52	DC Brake Select	[3] Logic OR	All set-ups		TRUE	-	Uint8
8-53	Start Select	[3] Logic OR	All set-ups		TRUE	-	Uint8
8-54	Reverse Select	[3] Logic OR	All set-ups		TRUE	-	Uint8
8-55	Set-up Select	[3] Logic OR	All set-ups		TRUE	-	Uint8
8-56	Preset Reference Select	[3] Logic OR	All set-ups		TRUE	-	Uint8
8-9* Bus Jog							
8-90	Bus Jog 1 Speed	100 RPM	All set-ups		TRUE	67	Uint16
8-91	Bus Jog 2 Speed	200 RPM	All set-ups		TRUE	67	Uint16

4.3.10. 9-** Profibus

Par. No. #	Parameter description	Default value	4-set-up	FC 302 only	Change during operation	Conver- sion index	Type
9-00	Setpoint	0 N/A	All set-ups		TRUE	0	Uint16
9-07	Actual Value	0 N/A	All set-ups		FALSE	0	Uint16
9-15	PCD Write Configuration	ExpressionLimit	2 set-ups		TRUE	-	Uint16
9-16	PCD Read Configuration	ExpressionLimit	2 set-ups		TRUE	-	Uint16
9-18	Node Address	126 N/A	1 set-up		TRUE	0	Uint8
9-22	Telegram Selection	[108] PPO 8	1 set-up		TRUE	-	Uint8
9-23	Parameters for Signals	0	All set-ups		TRUE	-	Uint16
9-27	Parameter Edit	[1] Enabled	2 set-ups		FALSE	-	Uint16
9-28	Process Control	[1] Enable cyclic master	2 set-ups		FALSE	-	Uint8
9-31	Safe Address	0 N/A	1 set-up		TRUE	0	Uint16
9-44	Fault Message Counter	0 N/A	All set-ups		TRUE	0	Uint16
9-45	Fault Code	0 N/A	All set-ups		TRUE	0	Uint16
9-47	Fault Number	0 N/A	All set-ups		TRUE	0	Uint16
9-52	Fault Situation Counter	0 N/A	All set-ups		TRUE	0	Uint16
9-53	Profibus Warning Word	0 N/A	All set-ups		TRUE	0	Uint16
9-63	Actual Baud Rate	0 N/A	All set-ups		TRUE	0	V2
9-64	Device Identification	[255] No baud rate found	All set-ups		TRUE	-	Uint8
9-65	Profile Number	0 N/A	All set-ups		TRUE	0	Uint16
9-67	Control Word 1	0 N/A	All set-ups		TRUE	0	OctStr[2]
9-68	Status Word 1	0 N/A	All set-ups		TRUE	0	V2
9-71	Profibus Save Data Values	[0] Off	All set-ups		TRUE	-	Uint8
9-72	ProfibusDriveReset	[0] No action	1 set-up		FALSE	-	Uint8
9-80	Defined Parameters (1)	0 N/A	All set-ups		FALSE	0	Uint16
9-81	Defined Parameters (2)	0 N/A	All set-ups		FALSE	0	Uint16
9-82	Defined Parameters (3)	0 N/A	All set-ups		FALSE	0	Uint16
9-83	Defined Parameters (4)	0 N/A	All set-ups		FALSE	0	Uint16
9-84	Defined Parameters (5)	0 N/A	All set-ups		FALSE	0	Uint16
9-90	Changed Parameters (1)	0 N/A	All set-ups		FALSE	0	Uint16
9-91	Changed Parameters (2)	0 N/A	All set-ups		FALSE	0	Uint16
9-92	Changed Parameters (3)	0 N/A	All set-ups		FALSE	0	Uint16
9-93	Changed Parameters (4)	0 N/A	All set-ups		FALSE	0	Uint16
9-94	Changed Parameters (5)	0 N/A	All set-ups		FALSE	0	Uint16
9-99	Profibus Revision Counter	0 N/A	All set-ups		TRUE	0	Uint16

4.3.1.1. 10-* * CAN Ser. Com. Bus

Par. No. #	Parameter description	Default value	4-set-up	FC 302 only	Change during operation	Conversion index	Type
10-0* Common Settings							
10-00	CAN Protocol	null	2 set-ups		FALSE	-	Uint8
10-01	Baud Rate Select	null	2 set-ups		TRUE	-	Uint8
10-02	MAC ID	ExpressionLimit	2 set-ups		TRUE	0	Uint8
10-05	Readout Transmit Error Counter	0 N/A	All set-ups		TRUE	0	Uint8
10-06	Readout Receive Error Counter	0 N/A	All set-ups		TRUE	0	Uint8
10-07	Readout Bus Off Counter	0 N/A	All set-ups		TRUE	0	Uint8
10-1* DeviceNet							
10-10	Process Data Type Selection	null	All set-ups		TRUE	-	Uint8
10-11	Process Data Config Write	ExpressionLimit	2 set-ups		TRUE	-	Uint16
10-12	Process Data Config Read	ExpressionLimit	2 set-ups		TRUE	-	Uint16
10-13	Warning Parameter	0 N/A	All set-ups		TRUE	0	Uint16
10-14	Net Reference	[0] Off	2 set-ups		TRUE	-	Uint8
10-15	Net Control	[0] Off	2 set-ups		TRUE	-	Uint8
10-2* COS Filters							
10-20	COS Filter 1	0 N/A	All set-ups		FALSE	0	Uint16
10-21	COS Filter 2	0 N/A	All set-ups		FALSE	0	Uint16
10-22	COS Filter 3	0 N/A	All set-ups		FALSE	0	Uint16
10-23	COS Filter 4	0 N/A	All set-ups		FALSE	0	Uint16
10-3* Parameter Access							
10-30	Array Index	0 N/A	2 set-ups		TRUE	0	Uint8
10-31	Store Data Values	[0] Off	All set-ups		TRUE	-	Uint8
10-32	DeviceNet Revision	ExpressionLimit	All set-ups		TRUE	0	Uint16
10-33	Store Always	[0] Off	1 set-up		TRUE	-	Uint8
10-34	DeviceNet Product Code	ExpressionLimit	1 set-up		TRUE	0	Uint16
10-39	DeviceNet F Parameters	0 N/A	All set-ups		TRUE	0	Uint32
10-5* CANopen							
10-50	Process Data Config Write.	ExpressionLimit	2 set-ups		TRUE	-	Uint16
10-51	Process Data Config Read.	ExpressionLimit	2 set-ups		TRUE	-	Uint16

4.3.12. 13-** Smart Logic

Par. No. #	Parameter description	Default value	4-set-up	FC 302 only	Change during operation	Conversion index	Type
13-0* SLC Settings							
13-00	SL Controller Mode	null	2 set-ups		TRUE	-	Uint8
13-01	Start Event	null	2 set-ups		TRUE	-	Uint8
13-02	Stop Event	null	2 set-ups		TRUE	-	Uint8
13-03	Reset SLC	[0] Do not reset SLC	All set-ups		TRUE	-	Uint8
13-1* Comparators							
13-10	Comparator Operand	null	2 set-ups		TRUE	-	Uint8
13-11	Comparator Operator	null	2 set-ups		TRUE	-	Uint8
13-12	Comparator Value	ExpressionLimit	2 set-ups		TRUE	-3	Int32
13-2* Timers							
13-20	SL Controller Timer	ExpressionLimit	1 set-up		TRUE	-3	TimD
13-4* Logic Rules							
13-40	Logic Rule Boolean 1	null	2 set-ups		TRUE	-	Uint8
13-41	Logic Rule Operator 1	null	2 set-ups		TRUE	-	Uint8
13-42	Logic Rule Boolean 2	null	2 set-ups		TRUE	-	Uint8
13-43	Logic Rule Operator 2	null	2 set-ups		TRUE	-	Uint8
13-44	Logic Rule Boolean 3	null	2 set-ups		TRUE	-	Uint8
13-5* States							
13-51	SL Controller Event	null	2 set-ups		TRUE	-	Uint8
13-52	SL Controller Action	null	2 set-ups		TRUE	-	Uint8

4.3.13. 14-* Special Functions

Par. No. #	Parameter description	Default value	4-set-up	FC 302 only	Change during operation	Conversion index	Type
14-0* Inverter Switching							
14-00	Switching Pattern	[1] SFAVM	All set-ups		TRUE	-	Uint8
14-01	Switching Frequency	null	All set-ups		TRUE	-	Uint8
14-03	Overmodulation	[1] On	All set-ups		FALSE	-	Uint8
14-04	PWM Random	[0] Off	All set-ups		TRUE	-	Uint8
14-1* Mains On/Off							
14-10	Line Failure	[0] No function	All set-ups		FALSE	-	Uint8
14-11	Line Voltage at Line Fault	ExpressionLimit	All set-ups		TRUE	0	Uint16
14-12	Function at Mains Imbalance	[0] Trip	All set-ups		TRUE	-	Uint8
14-2* Trip Reset							
14-20	Reset Mode	[0] Manual reset	All set-ups		TRUE	-	Uint8
14-21	Automatic Restart Time	10 s	All set-ups		TRUE	0	Uint16
14-22	Operation Mode	[0] Normal operation	All set-ups		TRUE	-	Uint8
14-23	Typecode Setting	null	2 set-ups		FALSE	-	Uint8
14-25	Trip Delay at Torque Limit	60 s	All set-ups		TRUE	0	Uint8
14-26	Trip Delay at Inverter Fault	ExpressionLimit	All set-ups		TRUE	0	Uint8
14-28	Production Settings	[0] No action	All set-ups		TRUE	-	Uint8
14-29	Service Code	0 N/A	All set-ups		TRUE	0	Int32
14-3* Current Limit Ctrl.							
14-30	Current Lim Cont, Proportional Gain	100 %	All set-ups		FALSE	0	Uint16
14-31	Current Lim Contr, Integration Time	0.020 s	All set-ups		FALSE	-3	Uint16
14-4* Energy Optimizing							
14-40	VT Level	66 %	All set-ups		FALSE	0	Uint8
14-41	AEO Minimum Magnetization	40 %	All set-ups		TRUE	0	Uint8
14-42	Minimum AEO Frequency	10 Hz	All set-ups		TRUE	0	Uint8
14-43	Motor Cos-Phi	ExpressionLimit	All set-ups		TRUE	-2	Uint16
14-5* Environment							
14-50	RFI 1	[1] On	1 set-up	x	FALSE	-	Uint8
14-52	Fan Control	[0] Auto	All set-ups		TRUE	-	Uint8
14-53	Fan Monitor	[1] Warning	All set-ups		TRUE	-	Uint8
14-55	Output Filter	[0] No Filter	1 set-up		FALSE	-	Uint8
14-56	Capacitance Output Filter	2.0 uF	1 set-up		FALSE	-7	Uint16
14-57	Inductance Output Filter	7.000 mH	1 set-up		FALSE	-6	Uint16
14-7* Compatibility							
14-72	VLT Alarm Word	0 N/A	All set-ups		FALSE	0	Uint32
14-73	VLT Warning Word	0 N/A	All set-ups		FALSE	0	Uint32
14-74	VLT Ext. Status Word	0 N/A	All set-ups		FALSE	0	Uint32

4.3.14. 15-** Drive Information

Par. No. #	Parameter description	Default value	4-set-up	FC 302 only	Change during operation	Conver- sion index	Type
15-0* Operating Data							
15-00	Operating Hours	0 h	All set-ups		FALSE	74	Uint32
15-01	Running Hours	0 h	All set-ups		FALSE	74	Uint32
15-02	kWh Counter	0 kWh	All set-ups		FALSE	75	Uint32
15-03	Power-ups	0 N/A	All set-ups		FALSE	0	Uint32
15-04	Over Temps	0 N/A	All set-ups		FALSE	0	Uint16
15-05	Over Volts	0 N/A	All set-ups		FALSE	0	Uint16
15-06	Reset kWh Counter	[0] Do not reset	All set-ups		TRUE	-	Uint8
15-07	Reset Running Hours Counter	[0] Do not reset	All set-ups		TRUE	-	Uint8
15-1* Data Log Settings							
15-10	Logging Source	0	2 set-ups		TRUE	-	Uint16
15-11	Logging Interval	ExpressionLimit	2 set-ups		TRUE	-3	TimD
15-12	Trigger Event	[0] FALSE	1 set-up		TRUE	-	Uint8
15-13	Logging Mode	[0] Log always	2 set-ups		TRUE	-	Uint8
15-14	Samples Before Trigger	50 N/A	2 set-ups		TRUE	0	Uint8
15-2* Historic Log							
15-20	Historic Log: Event	0 N/A	All set-ups		FALSE	0	Uint8
15-21	Historic Log: Value	0 N/A	All set-ups		FALSE	0	Uint32
15-22	Historic Log: Time	0 ms	All set-ups		FALSE	-3	Uint32
15-3* Fault Log							
15-30	Fault Log: Error Code	0 N/A	All set-ups		FALSE	0	Uint8
15-31	Fault Log: Value	0 N/A	All set-ups		FALSE	0	Int16
15-32	Fault Log: Time	0 s	All set-ups		FALSE	0	Uint32
15-4* Drive Identification							
15-40	FC Type	0 N/A	All set-ups		FALSE	0	VisStr[6]
15-41	Power Section	0 N/A	All set-ups		FALSE	0	VisStr[20]
15-42	Voltage	0 N/A	All set-ups		FALSE	0	VisStr[20]
15-43	Software Version	0 N/A	All set-ups		FALSE	0	VisStr[5]
15-44	Ordered Typecode String	0 N/A	All set-ups		FALSE	0	VisStr[40]
15-45	Actual Typecode String	0 N/A	All set-ups		FALSE	0	VisStr[40]
15-46	Adj Freq Dr Ordering No.	0 N/A	All set-ups		FALSE	0	VisStr[8]
15-47	Power Card Ordering No.	0 N/A	All set-ups		FALSE	0	VisStr[8]
15-48	LCP ID Num.	0 N/A	All set-ups		FALSE	0	VisStr[8]
15-49	SW ID Control Card	0 N/A	All set-ups		FALSE	0	VisStr[20]
15-50	SW ID Power Card	0 N/A	All set-ups		FALSE	0	VisStr[20]
15-51	Adj Freq Dr Serial No.	0 N/A	All set-ups		FALSE	0	VisStr[10]
15-53	Power Card Serial Number	0 N/A	All set-ups		FALSE	0	VisStr[19]

Par. No. #	Parameter description	Default value	4-set-up	FC 302 only	Change during operation	Conver- sion index	Type
15-6* Option Ident							
15-60	Option Mounted	0 N/A	All set-ups		FALSE	0	VisStrf[30]
15-61	Option SW Version	0 N/A	All set-ups		FALSE	0	VisStrf[20]
15-62	Option Ordering No	0 N/A	All set-ups		FALSE	0	VisStrf[8]
15-63	Option Serial No	0 N/A	All set-ups		FALSE	0	VisStrf[18]
15-70	Option in Slot A	0 N/A	All set-ups		FALSE	0	VisStrf[30]
15-71	Slot A Option SW Version	0 N/A	All set-ups		FALSE	0	VisStrf[20]
15-72	Option in Slot B	0 N/A	All set-ups		FALSE	0	VisStrf[30]
15-73	Slot B Option SW Version	0 N/A	All set-ups		FALSE	0	VisStrf[20]
15-74	Option in Slot C0	0 N/A	All set-ups		FALSE	0	VisStrf[30]
15-75	Slot C0 Option SW Version	0 N/A	All set-ups		FALSE	0	VisStrf[20]
15-76	Option in Slot C1	0 N/A	All set-ups		FALSE	0	VisStrf[30]
15-77	Slot C1 Option SW Version	0 N/A	All set-ups		FALSE	0	VisStrf[20]
15-9* Parameter Info							
15-92	Defined Parameters	0 N/A	All set-ups		FALSE	0	Uint16
15-93	Modified Parameters	0 N/A	All set-ups		FALSE	0	Uint16
15-99	Parameter Metadata	0 N/A	All set-ups		FALSE	0	Uint16

4.3.15. 16-** Data Readouts

Par. No. #	Parameter description	Default value	4-set-up	FC 302 only	Change during operation	Conversion index	Type
16-0* General Status							
16-00	Control Word	0 N/A	All set-ups		FALSE	0	V2
16-01	Reference [Unit]	0.000 ReferenceFeedbackUnit	All set-ups		FALSE	-3	Int32
16-02	Reference %	0.0 %	All set-ups		FALSE	-1	Int16
16-03	Status Word	0 N/A	All set-ups		FALSE	0	V2
16-05	Main Actual Value [%]	0.00 %	All set-ups		FALSE	-2	N2
16-09	Custom Readout	0.00 CustomReadoutUnit	All set-ups		FALSE	-2	Int32
16-1* Motor Status							
16-10	Power [kW]	0.00 kW	All set-ups		FALSE	1	Int32
16-11	Power [hp]	0.00 hp	All set-ups		FALSE	-2	Int32
16-12	Motor voltage	0.0 V	All set-ups		FALSE	-1	Uint16
16-13	Frequency	0.0 Hz	All set-ups		FALSE	-1	Uint16
16-14	Motor Current	0.00 A	All set-ups		FALSE	-2	Int32
16-15	Frequency [%]	0.00 %	All set-ups		FALSE	-2	N2
16-16	Torque [Nm]	0.0 Nm	All set-ups		FALSE	-1	Int32
16-17	Speed [RPM]	0 RPM	All set-ups		FALSE	67	Int32
16-18	Motor Thermal	0 %	All set-ups		FALSE	0	Uint8
16-19	KTY sensor temperature	0 °C	All set-ups		FALSE	100	Int16
16-20	Motor Angle	0 N/A	All set-ups		TRUE	0	Uint16
16-22	Torque [%]	0 %	All set-ups		FALSE	0	Int16
16-3* Drive Status							
16-30	DC Link Voltage	0 V	All set-ups		FALSE	0	Uint16
16-32	Brake Energy /s	0.000 kW	All set-ups		FALSE	0	Uint32
16-33	Brake Energy /2 min	0.000 kW	All set-ups		FALSE	0	Uint32
16-34	Heatsink Temp.	0 °C	All set-ups		FALSE	100	Uint8
16-35	Inverter Thermal	0 %	All set-ups		FALSE	0	Uint8
16-36	Inv. Nom. Current	ExpressionLimit	All set-ups		FALSE	-2	Uint32
16-37	Inv. Max. Current	ExpressionLimit	All set-ups		FALSE	-2	Uint32
16-38	SL Controller State	0 N/A	All set-ups		FALSE	0	Uint8
16-39	Control Card Temp.	0 °C	All set-ups		FALSE	100	Uint8
16-40	Logging Buffer Full	[0] No	All set-ups		TRUE	-	Uint8
16-5* Ref. & Feedsb.							
16-50	External Reference	0.0 N/A	All set-ups		FALSE	-1	Int16
16-51	Pulse Reference	0.0 N/A	All set-ups		FALSE	-1	Int16
16-52	Feedback [Unit]	0.000 ReferenceFeedbackUnit	All set-ups		FALSE	-3	Int32
16-53	Digi Pot. Reference	0.00 N/A	All set-ups		FALSE	-2	Int16

Par. No. #	Parameter description	Default value	4-set-up	FC 302 only	Change during operation	Conver- sion index	Type
16-6* Inputs & Outputs							
16-60	Digital Input	0 N/A	All set-ups		FALSE	0	Uint16
16-61	Terminal 53 Switch Setting	[0] Current	All set-ups		FALSE	-	Uint8
16-62	Analogue Input 53	0.000 N/A	All set-ups		FALSE	-3	Int32
16-63	Terminal 54 Switch Setting	[0] Current	All set-ups		FALSE	-	Uint8
16-64	Analogue Input 54	0.000 N/A	All set-ups		FALSE	-3	Int32
16-65	Analogue Output 42 [mA]	0.000 N/A	All set-ups		FALSE	-3	Int16
16-66	Digital Output [bin]	0 N/A	All set-ups		FALSE	0	Int16
16-67	Freq. Input #29 [Hz]	0 N/A	All set-ups	x	FALSE	0	Int32
16-68	Freq. Input #33 [Hz]	0 N/A	All set-ups		FALSE	0	Int32
16-69	Pulse Output #27 [Hz]	0 N/A	All set-ups		FALSE	0	Int32
16-70	Pulse Output #29 [Hz]	0 N/A	All set-ups	x	FALSE	0	Int32
16-71	Relay Output [bin]	0 N/A	All set-ups		FALSE	0	Int16
16-72	Counter A	0 N/A	All set-ups		TRUE	0	Int32
16-73	Counter B	0 N/A	All set-ups		TRUE	0	Int32
16-74	Prec. Stop Counter	0 N/A	All set-ups		TRUE	0	Uint32
16-75	Analog In X30/11	0.000 N/A	All set-ups		FALSE	-3	Int32
16-76	Analog In X30/12	0.000 N/A	All set-ups		FALSE	-3	Int32
16-77	Analog Out X30/8 [mA]	0.000 N/A	All set-ups		FALSE	-3	Int16
16-8* Fieldbus & FC Port							
16-80	Fieldbus CTW 1	0 N/A	All set-ups		FALSE	0	V2
16-82	Fieldbus REF 1	0 N/A	All set-ups		FALSE	0	N2
16-84	Comm. Option Status	0 N/A	All set-ups		FALSE	0	V2
16-85	FC Port CTW 1	0 N/A	All set-ups		FALSE	0	V2
16-86	FC Port REF 1	0 N/A	All set-ups		FALSE	0	N2
16-9* Diagnosis Readouts							
16-90	Alarm Word	0 N/A	All set-ups		FALSE	0	Uint32
16-91	Alarm word 2	0 N/A	All set-ups		FALSE	0	Uint32
16-92	Warning Word	0 N/A	All set-ups		FALSE	0	Uint32
16-93	Warning word 2	0 N/A	All set-ups		FALSE	0	Uint32
16-94	Ext. Status Word	0 N/A	All set-ups		FALSE	0	Uint32

4.3.16. 17-**-** Motor Feedb.Option

Par. No. #	Parameter description	Default value	4-set-up	FC 302 only	Change during operation	Conver- sion index	Type
17-1* Inc. Enc. Interface							
17-10	Signal Type	[1] TTL (5V, RS422)	All set-ups		FALSE	-	Uint8
17-11	Resolution (PPR)	1024 N/A	All set-ups		FALSE	0	Uint16
17-2* Abs. Enc. Interface							
17-20	Protocol Selection	[0] None	All set-ups		FALSE	-	Uint8
17-21	Resolution (Positions/Rev)	ExpressionLimit	All set-ups		FALSE	0	Uint32
17-24	SSI Data Length	13 N/A	All set-ups		FALSE	0	Uint8
17-25	Clock Rate	ExpressionLimit	All set-ups		FALSE	3	Uint16
17-26	SSI Data Format	[0] Gray code	All set-ups		FALSE	-	Uint8
17-34	HIPERFACE Baud rate	[4] 9600	All set-ups		FALSE	-	Uint8
17-5* Resolver Interface							
17-50	Poles	2 N/A	1 set-up		FALSE	0	Uint8
17-51	Input Voltage	7.0 V	1 set-up		FALSE	-1	Uint8
17-52	Input Frequency	10.0 kHz	1 set-up		FALSE	2	Uint8
17-53	Transformation Ratio	0.5 N/A	1 set-up		FALSE	-1	Uint8
17-59	Resolver Interface	[0] Disabled	All set-ups		FALSE	-	Uint8
17-6* Monitoring and App.							
17-60	Feedback Direction	[0] Clockwise	All set-ups		FALSE	-	Uint8
17-61	Feedback Signal Monitoring	[1] Warning	All set-ups		TRUE	-	Uint8

4.3.17. 32-* MCO Basic Settings

Par. No. #	Parameter description	Default value	4-set-up	FC 302 only	Change during operation	Conversion index	Type
32-0* Encoder 2							
32-00	Incremental Signal Type	[1] TTL (5V, RS422)	2 set-ups		TRUE	-	Uint8
32-01	Incremental Resolution	1024 N/A	2 set-ups		TRUE	0	Uint32
32-02	Absolute Protocol	[0] None	2 set-ups		TRUE	-	Uint8
32-03	Absolute Resolution	8192 N/A	2 set-ups		TRUE	0	Uint32
32-05	Absolute Encoder Data Length	25 N/A	2 set-ups		TRUE	0	Uint8
32-06	Absolute Encoder Clock Frequency	262.000 kHz	2 set-ups		TRUE	0	Uint32
32-07	Absolute Encoder Clock Generation	[1] On	2 set-ups		TRUE	-	Uint8
32-08	Absolute Encoder Cable Length	0 m	2 set-ups		TRUE	0	Uint16
32-09	Encoder Monitoring	[0] Off	2 set-ups		TRUE	-	Uint8
32-10	Rotational Direction	[1] No action	2 set-ups		TRUE	-	Uint8
32-11	User Unit Denominator	1 N/A	2 set-ups		TRUE	0	Uint32
32-12	User Unit Numerator	1 N/A	2 set-ups		TRUE	0	Uint32
32-3* Encoder 1							
32-30	Incremental Signal Type	[1] TTL (5V, RS422)	2 set-ups		TRUE	-	Uint8
32-31	Incremental Resolution	1024 N/A	2 set-ups		TRUE	0	Uint32
32-32	Absolute Protocol	[0] None	2 set-ups		TRUE	-	Uint8
32-33	Absolute Resolution	8192 N/A	2 set-ups		TRUE	0	Uint32
32-35	Absolute Encoder Data Length	25 N/A	2 set-ups		TRUE	0	Uint8
32-36	Absolute Encoder Clock Frequency	262.000 kHz	2 set-ups		TRUE	0	Uint32
32-37	Absolute Encoder Clock Generation	[1] On	2 set-ups		TRUE	-	Uint8
32-38	Absolute Encoder Cable Length	0 m	2 set-ups		TRUE	0	Uint16
32-39	Encoder Monitoring	[0] Off	2 set-ups		TRUE	-	Uint8
32-40	Encoder Termination	[1] On	2 set-ups		TRUE	-	Uint8
32-5* Feedback Source							
32-50	Source Slave	[2] Encoder 2	2 set-ups		TRUE	-	Uint8

Par. No. #	Parameter description	Default value	4-set-up	FC 302 only	Change during operation	Conver- sion index	Type
32-6* PID Controller							
32-60	Proportional factor	30 N/A	2 set-ups		TRUE	0	Uint32
32-61	Derivative factor	0 N/A	2 set-ups		TRUE	0	Uint32
32-62	Integral factor	0 N/A	2 set-ups		TRUE	0	Uint32
32-63	Limit Value for Integral Sum	1000 N/A	2 set-ups		TRUE	0	Uint16
32-64	PID Bandwidth	1000 N/A	2 set-ups		TRUE	0	Uint16
32-65	Velocity Feed-Forward	0 N/A	2 set-ups		TRUE	0	Uint32
32-66	Acceleration Feed-Forward	0 N/A	2 set-ups		TRUE	0	Uint32
32-67	Max. Tolerated Position Error	20000 N/A	2 set-ups		TRUE	0	Uint32
32-68	Reverse Behavior for Slave	[0] Reversing allowed	2 set-ups		TRUE	-	Uint8
32-69	Sampling Time for PID Control	1 ms	2 set-ups		TRUE	-3	Uint16
32-70	Scan Time for Profile Generator	1 ms	2 set-ups		TRUE	-3	Uint8
32-71	Size of the Control Window (Activation)	0 N/A	2 set-ups		TRUE	0	Uint32
32-72	Size of the Control Window (Deactiv.)	0 N/A	2 set-ups		TRUE	0	Uint32
32-8* Velocity & Accel.							
32-80	Maximum Velocity (Encoder)	1500 RPM	2 set-ups		TRUE	67	Uint32
32-81	Shortest Ramp	1.000 s	2 set-ups		TRUE	-3	Uint32
32-82	Ramp Type	[0] Linear	2 set-ups		TRUE	-	Uint8
32-83	Velocity Resolution	100 N/A	2 set-ups		TRUE	0	Uint32
32-84	Default Velocity	50 N/A	2 set-ups		TRUE	0	Uint32
32-85	Default Acceleration	50 N/A	2 set-ups		TRUE	0	Uint32

4.3.18. 33-** MCO Adv. Settings

Par. No. #	Parameter description	Default value	4-set-up	FC 302 only	Change during operation	Conversion index	Type
33-0* Home Motion							
33-00	Force HOME	[0] Home not forced	2 set-ups		TRUE	-	Uint8
33-01	Zero Point Offset from Home Pos.	0 N/A	2 set-ups		TRUE	0	Int32
33-02	Ramp for Home Motion	10 N/A	2 set-ups		TRUE	0	Uint32
33-03	Velocity of Home Motion	10 N/A	2 set-ups		TRUE	0	Int32
33-04	Behavior during Home Motion	[0] Reverse and Index	2 set-ups		TRUE	-	Uint8
33-1* Synchronization							
33-10	Synchronization Factor Master (M:S)	1 N/A	2 set-ups		TRUE	0	Int32
33-11	Synchronization Factor Slave (M:S)	1 N/A	2 set-ups		TRUE	0	Int32
33-12	Position Offset for Synchronization	0 N/A	2 set-ups		TRUE	0	Int32
33-13	Accuracy Window for Position Sync.	1000 N/A	2 set-ups		TRUE	0	Int32
33-14	Relative Slave Velocity Limit	0 %	2 set-ups		TRUE	0	Uint8
33-15	Marker Number for Master	1 N/A	2 set-ups		TRUE	0	Uint16
33-16	Marker Number for Slave	1 N/A	2 set-ups		TRUE	0	Uint16
33-17	Master Marker Distance	4096 N/A	2 set-ups		TRUE	0	Uint32
33-18	Slave Marker Distance	4096 N/A	2 set-ups		TRUE	0	Uint32
33-19	Master Marker Type	[0] Encoder Z positive	2 set-ups		TRUE	-	Uint8
33-20	Slave Marker Type	[0] Encoder Z positive	2 set-ups		TRUE	-	Uint8
33-21	Master Marker Tolerance Window	0 N/A	2 set-ups		TRUE	0	Uint32
33-22	Slave Marker Tolerance Window	0 N/A	2 set-ups		TRUE	0	Uint32
33-23	Start Behavior for Marker Sync	[0] Start Function 1	2 set-ups		TRUE	-	Uint16
33-24	Marker Number for Fault	10 N/A	2 set-ups		TRUE	0	Uint16
33-25	Marker Number for Ready	1 N/A	2 set-ups		TRUE	0	Uint16
33-26	Velocity Filter	0 us	2 set-ups		TRUE	-6	Int32
33-27	Offset Filter Time	0 ms	2 set-ups		TRUE	-3	Uint32
33-28	Marker Filter Configuration	[0] Marker filter 1	2 set-ups		TRUE	-	Uint8
33-29	Filter Time for Marker Filter	0 ms	2 set-ups		TRUE	-3	Int32
33-30	Maximum Marker Correction	0 N/A	2 set-ups		TRUE	0	Uint32
33-31	Synchronization Type	[0] Standard	2 set-ups		TRUE	-	Uint8
33-4* Limit Handling							
33-40	Behavior at End Limit Switch	[0] Call error handler	2 set-ups		TRUE	-	Uint8
33-41	Negative Software End Limit	-500000 N/A	2 set-ups		TRUE	0	Int32
33-42	Positive Software End Limit	500000 N/A	2 set-ups		TRUE	0	Int32
33-43	Negative Software End Limit Active	[0] Inactive	2 set-ups		TRUE	-	Uint8
33-44	Positive Software End Limit Active	[0] Inactive	2 set-ups		TRUE	-	Uint8
33-45	Time in Target Window	0 ms	2 set-ups		TRUE	-3	Uint8
33-46	Target Window LimitValue	1 N/A	2 set-ups		TRUE	0	Uint16
33-47	Size of Target Window	0 N/A	2 set-ups		TRUE	0	Uint16

Par. No. #	Parameter description	Default value	4-set-up	FC 302 only	Change during operation	Conver- sion index	Type
33-5* I/O Configuration							
33-50	Terminal X57/1 Digital Input	[0] No function	2 set-ups		TRUE	-	Uint8
33-51	Terminal X57/2 Digital Input	[0] No function	2 set-ups		TRUE	-	Uint8
33-52	Terminal X57/3 Digital Input	[0] No function	2 set-ups		TRUE	-	Uint8
33-53	Terminal X57/4 Digital Input	[0] No function	2 set-ups		TRUE	-	Uint8
33-54	Terminal X57/5 Digital Input	[0] No function	2 set-ups		TRUE	-	Uint8
33-55	Terminal X57/6 Digital Input	[0] No function	2 set-ups		TRUE	-	Uint8
33-56	Terminal X57/7 Digital Input	[0] No function	2 set-ups		TRUE	-	Uint8
33-57	Terminal X57/8 Digital Input	[0] No function	2 set-ups		TRUE	-	Uint8
33-58	Terminal X57/9 Digital Input	[0] No function	2 set-ups		TRUE	-	Uint8
33-59	Terminal X57/10 Digital Input	[0] No function	2 set-ups		TRUE	-	Uint8
33-60	Terminal X59/1 and X59/2 Mode	[1] Output	2 set-ups		FALSE	-	Uint8
33-61	Terminal X59/1 Digital Input	[0] No function	2 set-ups		TRUE	-	Uint8
33-62	Terminal X59/2 Digital Input	[0] No function	2 set-ups		TRUE	-	Uint8
33-63	Terminal X59/1 Digital Output	[0] No function	2 set-ups		TRUE	-	Uint8
33-64	Terminal X59/2 Digital Output	[0] No function	2 set-ups		TRUE	-	Uint8
33-65	Terminal X59/3 Digital Output	[0] No function	2 set-ups		TRUE	-	Uint8
33-66	Terminal X59/4 Digital Output	[0] No function	2 set-ups		TRUE	-	Uint8
33-67	Terminal X59/5 Digital Output	[0] No function	2 set-ups		TRUE	-	Uint8
33-68	Terminal X59/6 Digital Output	[0] No function	2 set-ups		TRUE	-	Uint8
33-69	Terminal X59/7 Digital Output	[0] No function	2 set-ups		TRUE	-	Uint8
33-70	Terminal X59/8 Digital Output	[0] No function	2 set-ups		TRUE	-	Uint8
33-8* Global Parameters							
33-80	Activated Program Number	-1 N/A	2 set-ups		TRUE	0	Int8
33-81	Power-up State	[1] Motor ON	2 set-ups		TRUE	-	Uint8
33-82	Drive Status Monitoring	[1] On	2 set-ups		TRUE	-	Uint8
33-83	Behavior After Error	[0] Coast	2 set-ups		TRUE	-	Uint8
33-84	Behavior after Esc.	[0] Controlled stop	2 set-ups		TRUE	-	Uint8
33-85	MCO Supplied by External 24VDC	[0] No	2 set-ups		TRUE	-	Uint8

4.3.19. 34-* MCO Data Readouts

Par. No. #	Parameter description	Default value	4-set-up	FC 302 only	Change during operation	Conversion index	Type
34-0* PCD Write Par.							
34-01	PCD 1 Write to MCO	0 N/A	All set-ups		TRUE	0	Uint16
34-02	PCD 2 Write to MCO	0 N/A	All set-ups		TRUE	0	Uint16
34-03	PCD 3 Write to MCO	0 N/A	All set-ups		TRUE	0	Uint16
34-04	PCD 4 Write to MCO	0 N/A	All set-ups		TRUE	0	Uint16
34-05	PCD 5 Write to MCO	0 N/A	All set-ups		TRUE	0	Uint16
34-06	PCD 6 Write to MCO	0 N/A	All set-ups		TRUE	0	Uint16
34-07	PCD 7 Write to MCO	0 N/A	All set-ups		TRUE	0	Uint16
34-08	PCD 8 Write to MCO	0 N/A	All set-ups		TRUE	0	Uint16
34-09	PCD 9 Write to MCO	0 N/A	All set-ups		TRUE	0	Uint16
34-10	PCD 10 Write to MCO	0 N/A	All set-ups		TRUE	0	Uint16
34-2* PCD Read Par.							
34-21	PCD 1 Read from MCO	0 N/A	All set-ups		TRUE	0	Uint16
34-22	PCD 2 Read from MCO	0 N/A	All set-ups		TRUE	0	Uint16
34-23	PCD 3 Read from MCO	0 N/A	All set-ups		TRUE	0	Uint16
34-24	PCD 4 Read from MCO	0 N/A	All set-ups		TRUE	0	Uint16
34-25	PCD 5 Read from MCO	0 N/A	All set-ups		TRUE	0	Uint16
34-26	PCD 6 Read from MCO	0 N/A	All set-ups		TRUE	0	Uint16
34-27	PCD 7 Read from MCO	0 N/A	All set-ups		TRUE	0	Uint16
34-28	PCD 8 Read from MCO	0 N/A	All set-ups		TRUE	0	Uint16
34-29	PCD 9 Read from MCO	0 N/A	All set-ups		TRUE	0	Uint16
34-30	PCD 10 Read from MCO	0 N/A	All set-ups		TRUE	0	Uint16
34-4* Inputs & Outputs							
34-40	Digital Inputs	0 N/A	All set-ups		TRUE	0	Uint16
34-41	Digital Outputs	0 N/A	All set-ups		TRUE	0	Uint16
34-5* Process Data							
34-50	Actual Position	0 N/A	All set-ups		TRUE	0	Int32
34-51	Commanded Position	0 N/A	All set-ups		TRUE	0	Int32
34-52	Actual Master Position	0 N/A	All set-ups		TRUE	0	Int32
34-53	Slave Index Position	0 N/A	All set-ups		TRUE	0	Int32
34-54	Master Index Position	0 N/A	All set-ups		TRUE	0	Int32
34-55	Curve Position	0 N/A	All set-ups		TRUE	0	Int32
34-56	Track Error	0 N/A	All set-ups		TRUE	0	Int32
34-57	Synchronizing Error	0 N/A	All set-ups		TRUE	0	Int32
34-58	Actual Velocity	0 N/A	All set-ups		TRUE	0	Int32
34-59	Actual Master Velocity	0 N/A	All set-ups		TRUE	0	Int32
34-60	Synchronizing Status	0 N/A	All set-ups		TRUE	0	Int32
34-61	Axis Status	0 N/A	All set-ups		TRUE	0	Int32
34-62	Program Status	0 N/A	All set-ups		TRUE	0	Int32
34-7* Diagnosis readouts							
34-70	MCO Alarm Word 1	0 N/A	All set-ups		FALSE	0	Uint32
34-71	MCO Alarm Word 2	0 N/A	All set-ups		FALSE	0	Uint32

5. General Specifications

Line power supply (L1, L2, L3):

Supply voltage	FC 302: 380-500 V ±10%
Supply voltage	FC 302: 525-690 V ±10%
Supply frequency	50/60 Hz
Max. imbalance temporary between line phases	3.0% of rated supply voltage
True Power Factor (λ)	≥ 0.9 nominal at rated load
Displacement Power Factor ($\cos \phi$) near unity	(> 0.98)
Switching on input supply L1, L2, L3 (power-ups) ≥ 15 hp [11 kW]	maximum 1 time/ 2 min.
Environment according to EN60664-1	overvoltage category III/pollution degree 2

The unit is suitable for use on a circuit capable of delivering not more than 100.000 RMS symmetrical Amperes, 500/600/690 V maximum.

Motor output (U, V, W):

Output voltage	0-100% of supply voltage
Output frequency	0 - 800 Hz
Switching on output	Unlimited
Ramp times	0.01 - 3600 sec.

Torque characteristics:

Starting torque (Constant torque)	maximum 160% for 60 sec.*
Starting torque	maximum 180% up to 0.5 sec.*
Overload torque (Constant torque)	maximum 160% for 60 sec.*
Starting torque (Variable torque)	maximum 110% for 60 sec.*
Overload torque (Variable torque)	maximum 110% for 60 sec.

**Percentage relates to the nominal torque.*

Digital inputs:

Programmable digital inputs	4 (6)
Terminal number	18, 19, 27 ¹⁾ , 29, 32, 33,
Logic	PNP or NPN
Voltage level	0-24 V DC
Voltage level, logic '0' PNP	< 5 V DC
Voltage level, logic '1' PNP	> 10 V DC
Voltage level, logic '0' NPN ²⁾	> 19 V DC
Voltage level, logic '1' NPN ²⁾	< 14 V DC
Maximum voltage on input	28 V DC
Pulse frequency range	0-110 kHz
(Duty cycle) Min. pulse width	4.5 ms
Input resistance, R _i	approximately 4 kΩ

5

Safe stop Terminal 37³⁾ (Terminal 37 is fixed PNP logic):

Voltage level	0-24 V DC
Voltage level, logic'0' PNP	< 4 V DC
Voltage level, logic'1' PNP	>20 V DC
Nominal input current at 24 V	50 mA rms
Nominal input current at 20 V	60 mA rms
Input capacitance	400 nF

All digital inputs are galvanically isolated from the supply voltage (PELV) and other high-voltage terminals.

1) Terminals 27 and 29 can also be programmed as output.

2) Except safe stop input Terminal 37.

3) Terminal 37 can only be used as safe stop input. Terminal 37 is suitable for category 3 installations in accordance with EN 954-1 (safe stop according to category 0 EN 60204-1), and as required by the EU Machinery Directive 98/37/EC. Terminal 37 and the safe stop function are designed in accordance with EN 60204-1, EN 50178, EN 61800-2, EN 61800-3 and EN 954-1. For correct and safe use of the Safe Stop function, follow the related information and instructions in the Design Guide.

Analog inputs:

Number of analog inputs	2
Terminal number	53, 54
Modes	Voltage or current
Mode select	Switch S201 and switch S202
Voltage mode	Switch S201/switch S202 = OFF (U)
Voltage level	-10 - +10 V (scalable)
Input resistance, R _i	approx. 10 kΩ
Max. voltage	± 20 V
Current mode	Switch S201/switch S202 = ON (I)
Current level	0/4 to 20 mA (scalable)
Input resistance, R _i	approx. 200 Ω
Max. current	30 mA
Resolution for analog inputs	10 bit (+ sign)
Accuracy of analog inputs	Max. error 0.5% of full scale
Bandwidth	100 Hz

The analog inputs are galvanically isolated from the supply voltage (PELV) and other high-voltage terminals.

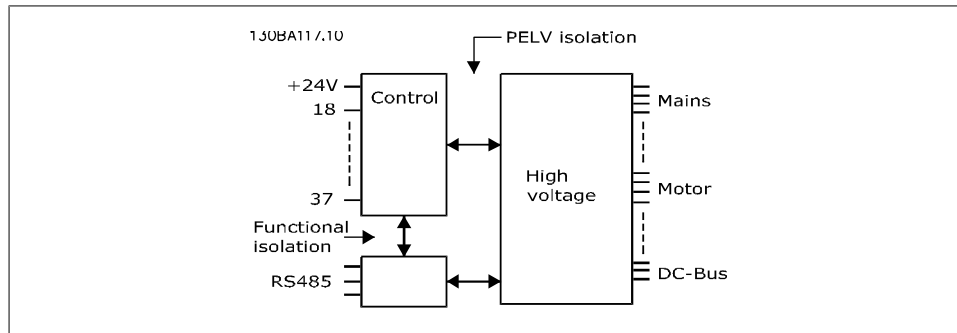

Pulse/encoder inputs:

Programmable pulse/encoder inputs	2/1
Terminal number pulse/encoder	29 ¹⁾ , 33 ²⁾ / 32 ³⁾ , 33 ³⁾
Max. frequency at terminal 29, 32, 33	110 kHz (push-pull driven)
Max. frequency at terminal 29, 32, 33	5 kHz (open collector)
Min. frequency at terminal 29, 32, 33	4 Hz
Voltage level	see section on Digital input
Maximum voltage on input	28 V DC
Input resistance, R _i	approximately 4 kΩ
Pulse input accuracy (0.1-1 kHz)	Max. error: 0.1% of full scale
Encoder input accuracy (1 - 110 kHz)	Max. error: 0.05% of full scale

The pulse and encoder inputs (terminals 29, 32, 33) are galvanically isolated from the supply voltage (PELV) and other high-voltage terminals.

- 1) FC 302 only
- 2) Pulse inputs are 29 and 33
- 3) Encoder inputs: 32 = A, and 33 = B

Digital output:

Programmable digital/pulse outputs	2
Terminal number	27, 29 ¹⁾
Voltage level at digital/frequency output	0-24 V
Max. output current (sink or source)	40 mA
Max. load at frequency output	1 kΩ
Max. capacitive load at frequency output	10 nF
Minimum output frequency at frequency output	0 Hz
Maximum output frequency at frequency output	32 kHz
Accuracy of frequency output	Max. error: 0.1% of full scale
Resolution of output frequency	12 bit

- 1) Terminal 27 and 29 can also be programmed as input.

The digital output is galvanically isolated from the supply voltage (PELV) and other high-voltage terminals.

Analog output:

Number of programmable analog outputs	1
Terminal number	42
Current range at analog output	0/4 - 20 mA
Max. load GND - analog output	500 Ω
Accuracy on analog output	Max. error: 0.5% of full scale
Resolution on analog output	12 bit

The analog output is galvanically isolated from the supply voltage (PELV) and other high-voltage terminals.

Control card, 24 V DC output:

Terminal number	12, 13
Output voltage	24 V +1, -3 V
Max. load	200 mA

The 24 V DC supply is galvanically isolated from the supply voltage (PELV), but has the same potential as the analog and digital inputs and outputs.

Control card, 10 V DC output:

Terminal number	50
Output voltage	10.5 V ±0.5 V
Max. load	15 mA

The 10 V DC supply is galvanically isolated from the supply voltage (PELV) and other high-voltage terminals.

Control card, RS-485 serial communication:

Terminal number	68 (P,TX+, RX+), 69 (N,TX-, RX-)
Terminal number 61	Common for terminals 68 and 69

The RS-485 serial communication circuit is functionally separated from other central circuits and galvanically isolated from the supply voltage (PELV).

Control card, USB serial communication:

USB standard	1.1 (Full speed)
USB plug	USB type B "device" plug

Connection to PC is carried out via a standard host/device USB cable.

The USB connection is galvanically isolated from the supply voltage (PELV) and other high-voltage terminals.

The USB ground connection is not galvanically isolated from protection ground. Use only an isolated laptop as PC connection to the USB connector on the adjustable frequency drive.

Relay outputs:

Programmable relay outputs	2
Relay 01 Terminal number	1-3 (break), 1-2 (make)
Max. terminal load (AC-1) ¹⁾ on 1-3 (NC), 1-2 (NO) (Resistive load)	240 V AC, 2 A
Max. terminal load (AC-15) ¹⁾ (Inductive load @ cosφ 0.4)	240 V AC, 0.2 A
Max. terminal load (DC-1) ¹⁾ on 1-2 (NO), 1-3 (NC) (Resistive load)	60 V DC, 1A
Max. terminal load (DC-13) ¹⁾ (Inductive load)	24 V DC, 0.1A
Relay 02 (FC 302 only) Terminal number	4-6 (break), 4-5 (make)
Max. terminal load (AC-1) ¹⁾ on 4-5 (NO) (Resistive load)	400 V AC, 2 A
Max. terminal load (AC-15) ¹⁾ on 4-5 (NO) (Inductive load @ cosφ 0.4)	240 V AC, 0.2 A
Max. terminal load (DC-1) ¹⁾ on 4-5 (NO) (Resistive load)	80 V DC, 2 A
Max. terminal load (DC-13) ¹⁾ on 4-5 (NO) (Inductive load)	24 V DC, 0.1A
Max. terminal load (AC-1) ¹⁾ on 4-6 (NC) (Resistive load)	240 V AC, 2 A
Max. terminal load (AC-15) ¹⁾ on 4-6 (NC) (Inductive load @ cosφ 0.4)	240 V AC, 0.2 A
Max. terminal load (DC-1) ¹⁾ on 4-6 (NC) (Resistive load)	50 V DC, 2 A
Max. terminal load (DC-13) ¹⁾ on 4-6 (NC) (Inductive load)	24 V DC, 0.1 A
Min. terminal load on 1-3 (NC), 1-2 (NO), 4-6 (NC), 4-5 (NO)	24 V DC 10 mA, 24 V AC 20 mA
Environment according to EN 60664-1	overvoltage category III/pollution degree 2

1) IEC 60947 part 4 and 5

The relay contacts are galvanically isolated from the rest of the circuit by reinforced isolation (PELV).

Cable lengths and cross-sections:

Max. motor cable length, shielded/armored	492 ft [150 m]
Max. motor cable length, unshielded/unarmored	984 ft [300 m]
Maximum cross-section to control terminals, flexible/rigid wire without cable end sleeves	0.0023 in. ² [1.5 mm ²]/16 AWG
Maximum cross-section to control terminals, flexible wire with cable end sleeves	0.0016 in. ² [1 mm ²]/18 AWG
Maximum cross-section to control terminals, flexible wire with cable end sleeves with collar	0.00078 in. ² [0.5 mm ²]/20 AWG
Minimum cross-section to control terminals	0.0039 in. ² [0.25 mm ²]/24 AWG

Control card performance:

Scan interval	1 ms
---------------	------

Control characteristics:

Resolution of output frequency at 0-1000 Hz	+/- 0.003 Hz
Repeat accuracy of <i>Precise start/stop</i> (terminals 18, 19)	≤± 0.1 msec
System response time (terminals 18, 19, 27, 29, 32, 33)	≤ 2 ms
Speed control range (open-loop)	1:100 of synchronous speed
Speed control range (closed-loop)	1:1000 of synchronous speed
Speed accuracy (open-loop)	30-4000 rpm: error ±8 rpm
Speed accuracy (closed-loop), depending on resolution of feedback device	0-6000 rpm: error ±0.15 rpm

All control characteristics are based on a 4-pole asynchronous motor

Surroundings:

Enclosure	IP 21/ Type 1, IP 54/ Type 12
Vibration test	1.0 g
Max. relative humidity	5%-95% (IEC 721-3-3; Class 3K3 (non-condensing) during operation)
Aggressive environment (IEC 60068-2-43)	class H25
Ambient temperature ¹⁾	Max. 122° F [50° C] (24-hour average maximum 113° F [45° C])

1) For high ambient temperature, see the special conditions in the Design Guide

Minimum ambient temperature during full-scale operation	32° F [0° C]
Minimum ambient temperature at reduced performance	14° F [-10° C]
Temperature during storage/transport	-13°-+149°/158° F [-25°-+65°/70° C]
Maximum altitude above sea level without derating	3280 ft [1000 m]

Derating for high altitude, see special conditions in the Design Guide.

EMC standards, Emission	EN 61800-3, EN 61000-6-3/4, EN 55011 EN 61800-3, EN 61000-6-1/2, EN 61000-4-2, EN 61000-4-3, EN 61000-4-4, EN 61000-4-5, EN 61000-4-6
EMC standards, Immunity	61000-4-6

See section on special conditions in the Design Guide

Protection and Features:

- Electronic thermal motor protection against overload.
- Temperature monitoring of the heatsink ensures that the adjustable frequency drive trips if the temperature reaches a predefined level. An overload temperature cannot be reset until the temperature of the heatsink is below the values stated in the tables on the following pages (Guideline - these temperatures may vary for different power sizes, enclosures, etc.).
- The adjustable frequency drive is protected against short-circuits on motor terminals U, V, W.
- If a line phase is missing, the adjustable frequency drive trips or issues a warning (depending on the load).
- Monitoring of the intermediate circuit voltage ensures that the adjustable frequency drive trips if the intermediate circuit voltage is too low or too high.
- The adjustable frequency drive constantly checks for critical levels of internal temperature, load current, high voltage on the intermediate circuit and low motor speeds. As a response to a critical level, the adjustable frequency drive can adjust the switching frequency and/or change the switching pattern in order to ensure the performance of the drive.

5.1.1. Product Specification:

380-500 Volt										
VLT Type		P110	P132	P160	P200					
	Output current	[VAC]	HO	NO	HO	NO	HO	NO	HO	NO
	Continuous (100/ 100%) [A]	400	212	260	260	315	315	395	395	480
	Intermittent (150/ 110%) [A]	400	318	286	390	347	473	435	593	528
	Continuous (100/ 100%) [A]	460/ 500	190	240	240	302	302	361	361	443
	Intermittent (150/ 110%) [A]	460/ 500	285	264	360	332	453	397	542	487
	Output kVA									
	Continuous (100/ 100%) [kVA]	400	147	180	180	218	218	274	274	333
	Intermittent (150/ 110%) [kVA]	400	220	198	270	240	327	301	410	366
	Continuous (100/ 100%) [kVA]	460	151	191	191	241	241	288	288	353
	Intermittent (150/ 110%) [kVA]	460	227	210	287	265	361	316	431	388
	Continuous (100/ 100%) [kVA]	500	165	208	208	262	262	313	313	384
	Intermittent (150/ 110%) [kVA]	500	247	229	312	288	392	344	469	422
	Typical Shaft Output									
	High Overload (150%) [kW]	400	110	132	132	160	160	200	200	250
	Normal Overload (110%) [kW]	400	132	160	160	200	200	250	250	315
	High Overload (150%) [HP]	460	150	200	200	250	250	300	300	384
	Normal Overload (110%) [HP]	460	200	250	250	300	300	350	350	480
	High Overload (150%) [kW]	500	132	160	160	200	200	250	250	315
	Normal Overload (110%) [kW]	500	160	200	200	250	250	315	315	400
	Max. Motor Cable Length	500 ft (150 m) shielded, 1,000 ft (300 m) unshielded								
	Output Voltage [%]	0-100% of the AC line voltage								
	Output Frequency [Hz]	0-450								
	Rated Motor Voltage [V]	400/460/500								
	Rated Motor Frequency [Hz]	50/60								
	Thermal protection during operation	ETR for motor (Class 20)								
	Thermal protection during operation	Deg C.	VLT trip	VLT trip	VLT trip	VLT trip	VLT trip	VLT trip	VLT trip	VLT trip
			90	105	105	105	105	115	115	115
	Switching on the Output	Unlimited								
	Ramp times [sec]	0.01 - 3600								

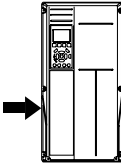
		380-500 Volt				
VLT Type		P110	P132	P160	P200	
						
Max. Input Current [A]		400	204 251 251	304 304	381 381 463	
Max. Input Current [A]		460/ 500	183 231 231	291 291	348 348 427	
Max. external pre-fuses¹⁾ [A]			350 400	500	600	
Soft Charge Fuses²⁾ AC [A] (qty)				20 (3)		
SMPS fuse³⁾ [A]				4		
AC Fan fuse³⁾ [A]				4		
Supply Voltage [V]				3 Phase, 380-500 ± 10%		
Supply Frequency [Hz]				50/ 60		
Power Factor				greater than 0.90		
Efficiency				0.98		
Power loss at rated max. load (400 V)						
High Overload (150%) [W]		2995	3425	3910	4625	
Normal Overload (110%) [W]		3782	4213	5119	5893	
Enclosure						
		IP 00, IP 21/ NEMA 1 & IP 54/ NEMA 12				
Vibration Test [g]		0.7				
Relative Humidity [%]		93%, +2%, -3% (IEC 68-2-3)				
Ambient Temperature [degrees C]		-10° C to 40° C [-14°-104° F] continuously, periodically at +45° C [113° F] -25° C to +65°/70° C [-13°-149°/158° F] for storage/ transport				
Adjustable Frequency Drive Protection		Ground and short-circuit protection				
Weight⁵⁾						
IP 00/ Chassis [kg]		90.5	111.8	122.9	137.7	
IP 21/ NEMA 1 [kg]		104.1	125.4	136.3	151.3	
IP 54/ NEMA 12 [kg]		104.1	125.4	136.3	151.3	

- 1) Bussman 170M6000 series. See fuse chart.
- 2) Bussmann FWH-20A6F or exact equivalent, 3 per unit
- 3) Bussmann KTK-4 or exact equivalent, 1 per unit
- 4) Littelfuse KLK-15 or exact equivalent, 1 per unit
- 5) VLT with standard input option, no brake, no load-share

380-500 Volt									
VLT Type		P250	P315	P355	P400				
Output current	[VAC]	HO	NO	HO	NO	HO	NO	HO	NO
Continuous (100/ 100%) [A]	400	480	600	600	658	658	745	695	800
Intermittent (150/ 110%) [A]	400	720	660	900	724	987	820	1043	880
Continuous (100/ 100%) [A]	460/ 500	443	540	540	590	590	678	678	730
Intermittent (150/ 110%) [A]	460/ 500	665	594	810	649	885	746	1017	803
Output kVA									
Continuous (100/ 100%) [kVA]	400	333	416	416	456	456	516	482	554
Intermittent (150/ 110%) [kVA]	400	499	457	624	501	684	568	723	610
Continuous (100/ 100%) [kVA]	460	353	430	430	470	470	540	540	582
Intermittent (150/ 110%) [kVA]	460	529	473	645	517	705	594	810	640
Continuous (100/ 100%) [kVA]	500	384	468	468	511	511	587	587	632
Intermittent (150/ 110%) [kVA]	500	575	514	701	562	766	646	881	695
Typical Shaft Output									
High Overload (150%) [kW]	400	250		315		355		400	
Normal Overload (110%) [kW]	400	315		355		400		450	
High Overload (150%) [HP]	460	350		450		500		550	
Normal Overload (110%) [HP]	460	450		500		600		600	
High Overload (150%) [kW]	500	315		355		400		500	
Normal Overload (110%) [kW]	500	355		400		500		530	
Max. Motor Cable Length	500 ft (150 m) shielded, 1,000 ft (300 m) unshielded								
Output Voltage [%]	0-100% of the AC line voltage								
Output Frequency [Hz]	0-300			0-200					
Rated Motor Voltage [V]	400/460/500								
Rated Motor Frequency [Hz]	50/60								
Thermal protection during operation	ETR for motor (Class 20)								
Thermal protection during operation	Deg C.	VLT trip at 203° F [95° C]							
Switching on the Output	Unlimited								
Ramp times [sec]	0.01 - 3600								

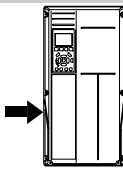
380-500 Volt				
VLT Type	P250	P315	P355	P400
				
Max. Input Current [A]	400	472	590	590
Max. Input Current [A]	460/ 500	436	531	531
Max. external pre-fuses ¹⁾ [A]		700	900	900
Soft Charge Fuses²⁾ AC [A] (qty)			20 (3)	
SMPS fuse³⁾ [A]			4	
AC Fan fuse ³⁾ [A]	4		15	
Supply Voltage [V]	3 Phase, 380-500 ± 10%			
Supply Frequency [Hz]	50/ 60			
Power Factor	greater than 0.90			
Efficiency	0.98			
Power loss at rated max. load (400 V)				
High Overload (150%) [W]	6005	6960	7691	7964
Normal Overload (110%) [W]	7630	7701	8879	9428
Enclosure				
	IP 00, IP 21/ NEMA 1 & IP 54/ NEMA 12			
Vibration Test [g]	0.7			
Relative Humidity [%]	93%, +2%, -3% (IEC 68-2-3)			
Ambient Temperature [degrees C]	-10° C to 40° C [14°-104° F] continuously, periodically at +45° C [113° F]			
	-25° C to +65°/70° C [-13°-149°/158° F] for storage/ transport			
Adjustable Drive Protection	Ground and short-circuit protection			
Weight ⁵⁾				
IP 00/ Chassis [kg]	221.4	234.1	236.4	277.3
IP 21/ NEMA 1 [kg]	263.2	270.0	272.3	313.2
IP 54/ NEMA 12 [kg]	263.2	270.0	272.3	313.2

- 1) Bussman 170M6000 series. See fuse chart.
- 2) Bussmann FWH-20A6F or exact equivalent, 3 per unit
- 3) Bussmann KTK-4 or exact equivalent, 1 per unit
- 4) Littlefuse KLK-15 or exact equivalent, 1 per unit
- 5) VLT with standard input option, no brake, no load sharing

525-690 Volt							
VLT Type		P110	P132	P160			
Output current	[VAC]	HO	NO	HO	NO	HO	NO
Continuous (100/ 100%) [A]	550	137	162	162	201	201	253
Intermittent (150/ 110%) [A]	550	206	178	243	221	302	278
Continuous (100/ 100%) [A]	575/ 690	131	155	155	192	192	242
Intermittent (150/ 110%) [A]	575/ 690	197	171	233	211	288	266
Output kVA							
Continuous (100/ 100%) [kVA]	550	131	154	154	191	191	241
Intermittent (150/ 110%) [kVA]	550	196	170	231	211	287	265
Continuous (100/ 100%) [kVA]	575	130	154	154	191	191	241
Intermittent (150/ 110%) [kVA]	575	196	170	232	210	287	265
Continuous (100/ 100%) [kVA]	690	157	185	185	229	229	289
Intermittent (150/ 110%) [kVA]	690	235	204	278	252	344	318
Typical Shaft Output							
High Overload (150%) [kW]	550	90	110	132			
Normal Overload (110%) [kW]	550	110	132	160			
High Overload (150%) [HP]	575	125	150	200			
Normal Overload (110%) [HP]	575	150	200	250			
High Overload (150%) [kW]	690	110	132	160			
Normal Overload (110%) [kW]	690	132	160	200			
Max. Motor Cable Length		500 ft (150 m) shielded, 1,000 ft (300 m) unshielded					
Output Voltage [%]		0-100% of the AC line voltage					
Output Frequency [Hz]		0-200					
Rated Motor Voltage [V]		550/ 575/ 690					
Rated Motor Frequency [Hz]		50/60					
Thermal protection during operation		ETR for motor (Class 20)					
Thermal protection during operation		85	90	110			
Switching on the Output		Unlimited					
Ramp times [sec]		0.01 - 3600					

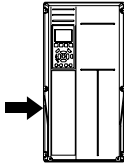
525-690 Volt				
VLT Type	P110	P132	P160	
				
Max. Input Current [A]	550	130	158	158 198 198 245
Max. Input Current [A]	575	124	151	151 189 189 234
Max. Input Current [A]	690	128	155	155 197 197 240
Max. external pre-fuses¹⁾ [A]		225	250	350
Soft Charge Fuses²⁾ AC [A] (qty)				20 (3)
SMPS fuse³⁾ [A]				4
AC Fan fuse³⁾ [A]				4
Supply Voltage [V]				3 Phase, 525-690 ± 10%
Supply Frequency [Hz]				50/ 60
Power Factor				>0.90 for 525 V, >0.85 for 690 V
Efficiency				0.98
Power loss at rated max. load (690 V)				
High Overload (150%) [W]		2665	2953	3451
Normal Overload (110%) [W]		3114	3612	4293
Enclosure				
				IP 00, IP 21/ NEMA 1 & IP 54/ NEMA 12
Vibration Test [g]				0.7
Relative Humidity [%]				93%, +2%, -3% (IEC 68-2-3)
Ambient Temperature [degrees C]				-10° C to 40° C [14°-104° F] continuously, periodically at +45° C [113° F] -25° C to +65°/70° C [-13°-149°/158° F] for storage/ transport
Adjustable Frequency Drive Protection				Ground and short-circuit protection
Weight⁵⁾				
IP 00/ Chassis [kg]		81.9	90.5	111.8
IP 21/ NEMA 1 [kg]		95.5	104.1	125.4
IP 54/ NEMA 12 [kg]		95.5	104.1	125.4

- 1) Bussman 170M6000 series. See fuse chart.
- 2) Bussmann FWH-20A6F or exact equivalent, 3 per unit
- 3) Bussmann KTK-4 or exact equivalent, 1 per unit
- 4) Littlefuse KLK-15 or exact equivalent, 1 per unit
- 5) VLT with standard input option, no brake, no load sharing

525-690 Volt									
VLT Type		P200	P250	P315	P355				
Output current	[VAC]	HO	NO	HO	NO	HO	NO	HO	NO
Continuous (100/ 100%) [A]	550	253	303	303	360	360	418	395	470
Intermittent (150/ 110%) [A]	550	380	333	455	396	540	460	593	517
Continuous (100/ 100%) [A]	575/ 690	242	290	290	344	344	400	380	450
Intermittent (150/ 110%) [A]	575/ 690	363	319	435	378	516	440	570	495
Output kVA									
Continuous (100/ 100%) [kVA]	550	241	289	289	343	343	398	376	448
Intermittent (150/ 110%) [kVA]	550	362	318	433	377	514	438	564	493
Continuous (100/ 100%) [kVA]	575	241	289	289	343	343	398	378	448
Intermittent (150/ 110%) [kVA]	575	362	318	433	377	514	438	568	493
Continuous (100/ 100%) [kVA]	690	289	347	347	411	411	478	454	538
Intermittent (150/ 110%) [kVA]	690	434	381	520	452	617	526	681	592
Typical Shaft Output									
High Overload (150%) [kW]	550	160		200		250		315	
Normal Overload (110%) [kW]	550	200		250		315		355	
High Overload (150%) [HP]	575	250		300		350		400	
Normal Overload (110%) [HP]	575	300		350		400		450	
High Overload (150%) [kW]	690	200		250		315		355	
Normal Overload (110%) [kW]	690	250		315		400		450	
Max. Motor Cable Length		500 ft (150 m) shielded, 1,000 ft (300 m) unshielded							
Output Voltage [%]		0-100% of the AC line voltage							
Output Frequency [Hz]		0-200				0-150			
Rated Motor Voltage [V]		550/ 575/ 690							
Rated Motor Frequency [Hz]		50/60							
Thermal protection during operation		ETR for motor (Class 20)							
Thermal protection during operation		110		110		110		85	
Switching on the Output		Unlimited							
Ramp times [sec]		0.01 - 3600							

5

		525-690 Volt								
VLT Type		P200	P250	P315	P355					
Max. Input Current [A]		550	245	299	299	355	355	408	381	453
Max. Input Current [A]		575	234	286	286	339	339	390	366	434
Max. Input Current [A]		690	240	296	296	352	352	400	366	434
Max. external pre-fuses ¹⁾ [A]			400		500		600		700	
Soft Charge Fuses²⁾ AC [A] (qty)								20 (3)		
SMPS fuse³⁾ [A]									4	
AC Fan fuse ³⁾ [A]									4	
Supply Voltage [V]									3 Phase, 525-690 ± 10%	
Supply Frequency [Hz]									50/ 60	
Power Factor									>0.90 for 525 V, >0.85 for 690 V	
Efficiency									0.98	
Power loss at rated max. load (690 V)										
High Overload (150%) [W]			4275		4875		5185		5383	
Normal Overload (110%) [W]			5156		5821		6149		6449	
Enclosure										
									IP 00, IP 21/ NEMA 1 & IP 54/ NEMA 12	
Vibration Test [g]									0.7	
Relative Humidity [%]									93%, +2%, -3% (IEC 68-2-3)	
Ambient Temperature [degrees C]									-10° C to 40° C [14°-104° F] continuously, periodically at +45° C [113° F] -25° C to +65°/70° C [-13°-149°/158° F] for storage/ transport	
Adjustable Frequency Drive Protection									Ground and short-circuit protection	
Weight ⁵⁾										
IP 00/ Chassis [kg]			122.9		137.7		151.3		221	
IP 21/ NEMA 1 [kg]			136.3		151.3		164.9		263	
IP 54/ NEMA 12 [kg]			136.3		151.3		164.9		263	

- 1) Bussman 170M6000 series. See fuse chart.
- 2) Bussmann FWH-20A6F or exact equivalent, 3 per unit
- 3) Bussmann KTK-4 or exact equivalent, 1 per unit
- 4) Littlefuse KLK-15 or exact equivalent, 1 per unit
- 5) VLT with standard input option, no brake, no load sharing

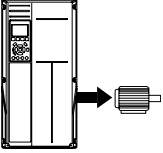
525-690 Volt							
VLT Type		P400	P500	P560			
							
Output current	[VAC]	HO	NO	HO	NO	HO	NO
Continuous (100/ 100%) [A]	550	429	523	523	596	596	630
Intermittent (150/ 110%) [A]	550	644	575	785	656	894	693
Continuous (100/ 100%) [A]	575/ 690	410	500	500	570	570	630
Intermittent (150/ 110%) [A]	575/ 690	615	550	750	627	855	693
Output kVA							
Continuous (100/ 100%) [kVA]	550	409	498	498	568	568	600
Intermittent (150/ 110%) [kVA]	550	613	548	747	625	852	660
Continuous (100/ 100%) [kVA]	575	408	498	498	568	568	627
Intermittent (150/ 110%) [kVA]	575	612	548	747	624	852	690
Continuous (100/ 100%) [kVA]	690	490	598	598	681	681	753
Intermittent (150/ 110%) [kVA]	690	735	657	896	749	1022	828
Typical Shaft Output							
High Overload (150%) [kW]	550	315		400		450	
Normal Overload (110%) [kW]	550	400		450		500	
High Overload (150%) [HP]	575	400		500		600	
Normal Overload (110%) [HP]	575	500		600		650	
High Overload (150%) [kW]	690	400		500		560	
Normal Overload (110%) [kW]	690	500		560		630	
Max. Motor Cable Length		500 ft (150 m) shielded, 1,000 ft (300 m) unshielded					
Output Voltage [%]		0-100% of the AC line voltage					
Output Frequency [Hz]		0-150					
Rated Motor Voltage [V]		550/ 575/ 690					
Rated Motor Frequency [Hz]		50/60					
Thermal protection during operation		ETR for motor (Class 20)					
Thermal protection during operation		85		85		85	
Switching on the Output		Unlimited					
Ramp times [sec]		0.01 - 3600					

5

525-690 Volt							
VLT Type	P400	P500	P560		P670		
Max. Input Current [A]	550	413	504	504	574	574	607
Max. Input Current [A]	575	395	482	482	549	549	607
Max. Input Current [A]	690	395	482	482	549	549	607
Max. external pre-fuses¹⁾ [A]		700			900		900
Soft Charge Fuses²⁾ AC [A] (qty)					20 (3)		
SMPS fuse³⁾ [A]					4		
AC Fan fuse³⁾ [A]		4				15	
Supply Voltage [V]					3 Phase, 525-690 ± 10%		
Supply Frequency [Hz]					50/ 60		
Power Factor					>0.90 for 525 V		
Efficiency					0.98		
Power loss at rated max. load (690 V)							
High Overload (150%) [W]		5818			7671		8715
Normal Overload (110%) [W]		7249			8727		9673
Enclosure							
					IP 00, IP 21/ NEMA 1 & IP 54/ NEMA 12		
Vibration Test [g]							
					0.7		
Relative Humidity [%]							
					93%, +2%, -3% (IEC 68-2-3)		
Ambient Temperature [degrees C]							
					-10° C to 40° C [14°-104° F] continuously, periodically at +45° C [113° F] -25° C to +65°/70° C [-13°-149°/158° F] for storage/ transport		
Adjustable Frequency Drive Protection							
					Ground and short-circuit protection		
Weight⁵⁾							
IP 00/ Chassis [kg]		221			236		277
IP 21/ NEMA 1 [kg]		263			272		313
IP 54/ NEMA 12 [kg]		263			272		313

- 1) Bussman 170M6000 series. See fuse chart.
- 2) Bussmann FWH-20A6F or exact equivalent, 3 per unit
- 3) Bussmann KTK-4 or exact equivalent, 1 per unit
- 4) Littlefuse KLK-15 or exact equivalent, 1 per unit
- 5) VLT with standard input option, no brake, no load sharing

6. Warnings and Alarms

6.1. Status Messages

6.1.1. Warnings/Alarm Messages

A warning or an alarm is signaled by the relevant LED on the front of the adjustable frequency drive, indicated by a code on the display.

A warning remains active until its cause is no longer present. Under certain circumstances, operation of the motor may still be continued. Warning messages may be critical, but are not necessarily so.

In the event of an alarm, the adjustable frequency drive will have tripped. Alarms must be reset to restart operation once their cause has been rectified.

This may be done in three ways:

1. By using the [RESET] control button on the LCP control panel.
2. Via a digital input with the "Reset" function.
3. Via serial communication/optional serial communication bus.



NOTE

After a manual reset using the [RESET] button on the LCP, the [AUTO ON] button must be pressed to restart the motor.

If an alarm cannot be reset, the reason may be that its cause has not been rectified, or that the alarm is trip-locked (see also the table on following page).

Alarms that are trip-locked offer additional protection, meaning that the line supply must be switched off before the alarm can be reset. After being switched back on, the adjustable frequency drive is no longer blocked and may be reset as described above, once the cause has been rectified.

Alarms that are not trip-locked can also be reset using the automatic reset function in parameters 14-20 (Warning: automatic wake-up is possible!)

If a warning and alarm are marked against a code in the table on the following page, this means that either a warning occurs before an alarm, or that you can specify whether it is a warning or an alarm that is to be displayed for a given fault.

This is possible, for instance, in parameters 1-90 *Motor Thermal Protection*. After an alarm or trip, the motor carries on coasting, and the alarm and warning flash. Once the problem has been rectified, only the alarm continues flashing until the adjustable frequency drive is reset.

No	Description	Warning	Alarm/Trip	Alarm/Trip Lock	Parameter Reference
1	10 Volts low	X			
2	Live zero error	(X)	(X)		6-01
3	No motor	(X)			1-80
4	Line phase loss	(X)	(X)	(X)	14-12
5	DC link voltage high	X			
6	DC link voltage low	X			
7	DC overvoltage	X	X		
8	DC undervoltage	X	X		
9	Inverter overloaded	X	X		
10	Motor ETR overtemperature	(X)	(X)		1-90
11	Motor thermistor overtemperature	(X)	(X)		1-90
12	Torque limit	X	X		
13	Overcurrent	X	X	X	
14	Ground Fault	X	X	X	
15	Hardware mismatch		X	X	
16	Short Circuit		X	X	
17	Control word timeout	(X)	(X)		8-04
23	Internal Fan Fault	X			
24	External Fan Fault	X			14-53
25	Brake resistor short-circuited	X			
26	Brake resistor power limit	(X)	(X)		2-13
27	Brake chopper short-circuited	X	X		
28	Brake check	(X)	(X)		2-15
29	Power board overtemp.	X	X	X	
30	Motor phase U missing	(X)	(X)	(X)	4-58
31	Motor phase V missing	(X)	(X)	(X)	4-58
32	Motor phase W missing	(X)	(X)	(X)	4-58
33	Soft-charge fault		X	X	
34	Serial communication bus fault	X	X		
36	Line failure	X	X		
38	Internal Fault		X	X	
40	Overload of Digital Output Terminal 27	(X)			5-00, 5-01
41	Overload of Digital Output Terminal 29	(X)			5-00, 5-02
42	Overload of Digital Output On X30/6	(X)			5-32
42	Overload of Digital Output On X30/7	(X)			5-33
47	24 V supply low	X	X	X	
48	1.8 V supply low		X	X	
49	Speed limit	X			
50	AMA calibration failed		X		
51	AMA check U_{nom} and I_{nom}		X		
52	AMA low I_{nom}		X		
53	AMA motor too big		X		
54	AMA motor too small		X		
55	AMA parameter out of range		X		
56	AMA interrupted by user		X		
57	AMA timeout		X		
58	AMA internal fault	X	X		
59	Current limit	X			

6.1: Alarm/Warning code list

No.	Description	Warning	Alarm/Trip	Alarm/Trip Lock	Parameter Reference
61	Tracking Error	(X)	(X)		4-30
62	Output Frequency at Maximum Limit	X			
63	Mechanical Brake Low		(X)		2-20
64	Voltage Limit	X			
65	Control Board Overtemperature	X	X	X	
66	Heatsink Temperature Low	X			
67	Option Configuration Has Changed		X		
68	Safe Stop	(X)	(X) ¹⁾		5-19
70	Illegal FC configuration			X	
71	PTC 1 Safe Stop	X	X ¹⁾		5-19
72	Dangerous Failure			X ¹⁾	5-19
80	Drive Initialized to Default Value		X		
90	Encoder Loss	(X)	(X)		17-61
91	Analog input 54 wrong settings			X	S202
100-199	See Instruction Manual for MCO 305				
250	New spare part			X	14-23
251	New Type Code		X	X	

6.2: Alarm/Warning code list

(X) Dependent on parameter

1) Cannot be auto-reset via Par 14-20

A trip is the action taken when an alarm has occurred. The trip will coast the motor and can be reset by pressing the reset button or make a reset by a digital input (Par. 5-1* [1]). The event that causes an alarm cannot damage the drive or result in dangerous conditions. A trip lock is the action taken when an alarm occurs that may cause damage to the drive or

its connected parts. A trip lock situation can only be reset by a power cycling.

LED indication

Warning	yellow
Alarm	flashing red
Trip-locked	yellow and red

Alarm Word Extended Status Word							
Bit	Hex	Dec	Alarm Word	Alarm Word 2	Warning Word	Warning Word 2	Extended Status Word
0	00000001	1	Brake Check	ServiceTrip, Read/Write	Brake Check		Ramping
1	00000002	2	Pwr. Card Temp	ServiceTrip, (reserved)	Pwr. Card Temp		AMA Running
2	00000004	4	Ground Fault	ServiceTrip, Typecode/ Sparepart	Ground Fault		Start CW/CCW
3	00000008	8	Ctrl.Card Temp	ServiceTrip, (reserved)	Ctrl.Card Temp		Slow-down
4	00000010	16	Ctrl. Word TO	ServiceTrip, (reserved)	Ctrl. Word TO		Catch Up
5	00000020	32	Overcurrent		Overcurrent		Feedback High
6	00000040	64	Torque Limit		Torque Limit		Feedback Low
7	00000080	128	Motor Th Over		Motor Th Over		Output Current High
8	00000100	256	Motor ETR Over		Motor ETR Over		Output Current Low
9	00000200	512	Inverter Overld.		Inverter Overld.		Output Freq High
10	00000400	1024	DC Undervolt		DC Undervolt		Output Freq Low
11	00000800	2048	DC Overvolt		DC Overvolt		Brake Check OK
12	00001000	4096	Short Circuit		DC Voltage Low		Braking Max
13	00002000	8192	Soft-charge fault		DC Voltage High		Braking
14	00004000	16384	Line ph. Loss		Line ph. Loss		Out of Speed Range
15	00008000	32768	AMA Not OK		No Motor		OVC Active
16	00010000	65536	Live Zero Error		Live Zero Error		AC Brake
17	00020000	131072	Internal Fault	KTY error	10 V Low	KTY Warn	Password Time-lock
18	00040000	262144	Brake Overload	Fans error	Brake Overload	Fans Warn	Password Protection
19	00080000	524288	U-phase Loss	ECB error	Brake Resistor	ECB Warn	
20	00100000	1048576	V-phase Loss		Brake IGBT		
21	00200000	2097152	W-phase Loss		Speed Limit		
22	00400000	4194304	Ser. com. bus fault		Ser. com. bus fault		Unused
23	00800000	8388608	24 V Supply Low		24 V Supply Low		Unused
24	01000000	16777216	Line Failure		Line Failure		Unused
25	02000000	33554432	1.8 V Supply Low		Current Limit		Unused
26	04000000	67108864	Brake Resistor		Low Temp		Unused
27	08000000	134217728	Brake IGBT		Voltage Limit		Unused
28	10000000	268435456	Option Change		Encoder loss		Unused
29	20000000	536870912	Drive Initialized		Output freq. lim.		Unused
30	40000000	1073741824	Safe Stop (A68)	PTC 1 Safe Stop (A71)	Safe Stop (W68)	PTC 1 Safe Stop (W71)	Unused
31	80000000	2147483648	Mech. brake low	Dangerous Failure (A72)	Extended Word	Status	Unused

6.3: Description of Alarm Word, Warning Word, and extended Status Word

The alarm words, warning words and extended status words can be read out via the serial communication bus (or optional serial communication bus) for diagnosis. See also par. 16-90 - 16-94.

WARNING 1, 10 Volts low:

The 10 V voltage from terminal 50 on the control card is below 10 V.

Remove a portion of the load from terminal 50, as the 10 v supply is overloaded. Max. 15 mA or minimum 590 Ω.

WARNING/ALARM 2, Live zero error:

The signal on terminal 53 or 54 is less than 50% of the value set in par. 6-10, 6-12, 6-20 or 6-22, respectively.

WARNING/ALARM 3, No motor:

No motor has been connected to the output of the adjustable frequency drive.

WARNING/ALARM 4, Line phase loss:

A phase is missing on the supply side, or the line voltage imbalance is too high.

This message also appears in case of a fault in the input rectifier on the adjustable frequency drive.

Check the supply voltage and supply currents to the adjustable frequency drive.

WARNING 5, DC link voltage high:

The intermediate circuit voltage (DC) is higher than the overvoltage limit of the control system. The adjustable frequency drive is still active.

WARNING 6, DC link voltage low

The intermediate circuit voltage (DC) is below the undervoltage limit of the control system. The adjustable frequency drive is still active.

WARNING/ALARM 7, DC overvoltage:

If the intermediate circuit voltage exceeds the limit, the adjustable frequency drive trips after a given period of time.

Possible corrections:

- Connect a brake resistor
- Extend the ramp time
- Activate functions in par. 2-10
- Increase par. 14-26

Alarm/warning limits:		
Adjustable frequency drive:	3 x 380-500 V [VDC]	3 x 525-690 V [VDC]
Undervoltage	402	553
Voltage warning low	423	585
Voltage warning high (w/o brake - w/brake)	817/828	1084/1109
Overvoltage	855	1130

The voltages stated are the intermediate circuit voltage of the adjustable frequency drive with a tolerance of ± 5%. The corresponding AC line voltage is the intermediate circuit voltage (DC link) divided by 1.35.

WARNING/ALARM 8, DC undervoltage:

If the intermediate circuit voltage (DC) drops below the "voltage warning low" limit (see table above), the adjustable frequency drive checks if 24 V backup supply is connected. If no 24 V backup supply is connected, the adjustable frequency drive trips after a given period of time, depending on the unit. To check whether the supply voltage matches the adjustable frequency drive, see *General Specifications*.

WARNING/ALARM 9, Inverter overloaded:

The adjustable frequency drive is about to cut out because of an overload (too high current for too long). The counter for electronic, thermal inverter protection gives a warning at 98% and trips at 100%, while giving an alarm. You cannot reset the adjustable frequency drive until the counter is below 90%.

The fault is that the adjustable frequency drive is overloaded by more than 100% for too long.

WARNING/ALARM 10, Motor ETR over-temperature:

According to the electronic thermal protection (ETR), the motor is too hot. You can choose if you want the adjustable frequency drive to give a warning or an alarm when the counter reaches 100% in par. 1-90. The fault is that the motor is overloaded by more than 100% for too long. Check that the motor par. 1-24 is set correctly.

WARNING/ALARM 11, Motor thermistor overtemp:

The thermistor or the thermistor connection is disconnected. You can choose if you want the adjustable frequency drive to give a warning or an alarm when the counter reaches 100% in par. 1-90. Make sure that the thermistor is connected correctly between terminal 53 or 54 (analog voltage input) and terminal 50 (+10 V supply), or between terminal 18 or 19 (digital input PNP only) and terminal 50. If aKTY sensor is used, check for correct connection between terminal 54 and 55.

WARNING/ALARM 12, Torque limit:

The torque is higher than the value in par. 4-16 (in motor operation), or the torque is higher than the value in par. 4-17 (in regenerative operation).

WARNING/ALARM 13, Overcurrent:

The inverter peak current limit (approximately 200% of the rated current) is exceeded. The warning will last approximately 8-12 sec., then the adjustable frequency drive trips and issues an alarm. Turn off the adjustable frequency drive and check if the motor shaft can be turned and if the motor size matches the adjustable frequency drive.

If extended mechanical brake control is selected, trip can be reset externally.

ALARM 14, Ground fault:

There is a discharge from the output phases to ground, either in the cable between the adjustable frequency drive and the motor or in the motor itself.

Turn off the adjustable frequency drive and remove the ground fault.

ALARM 15, Incomplete hardware:

A fitted option is not handled by the present control board (hardware or software).

ALARM 16, Short-circuit:

There is a short-circuit in the motor or on the motor terminals.

Turn off the adjustable frequency drive and remove the short-circuit.

WARNING/ALARM 17, Control word timeout:

There is no communication to the adjustable frequency drive.

The warning will only be active when par. 8-04 is NOT set to *OFF*.

If par. 8-04 is set to *Stop* and *Trip*, a warning appears and the adjustable frequency drive ramps down until it trips, while giving an alarm.

par. 8-03 *Control word Timeout Time* could possibly be increased.

WARNING 23, Internal fan fault:

The fan warning function is an extra protection function that checks if the fan is running/mounted. The fan warning can be disabled in *Fan Monitor*, par. 14-53, (set to [0] Disabled).

WARNING 24, External fan fault:

The fan warning function is an extra protection function that checks if the fan is running/mounted. The fan warning can be disabled in *Fan Monitor*, par. 14-53, (set to [0] Disabled).

WARNING 25, Brake resistor short-circuited:

The brake resistor is monitored during operation. If it short-circuits, the brake function is disconnected and the warning appears. The adjustable frequency drive still works, but without the brake function. Turn off the adjustable frequency drive and replace the brake resistor (see par. 2-15 *Brake Check*).

ALARM/WARNING 26, Brake resistor power limit:

The power transmitted to the brake resistor is calculated as a percentage, as a mean value over the last 120 s based on the resistance value of the brake resistor (par. 2-11) and the intermediate circuit voltage. The warning is active when the dissipated braking energy is higher than 90%. If *Trip* [2] has been selected in par. 2-13, the adjustable frequency drive cuts out and issues this alarm when the dissipated braking energy is higher than 100%.

ALARM/ WARNING 27, Brake chopper fault:

The brake transistor is monitored during operation, and if it short-circuits, the brake function disconnects and the warning is issued. The adjustable frequency drive is still able to run, but since the brake transistor has short-circuited, substantial power is transmitted to the brake resistor, even if it is inactive.

Turn off the adjustable frequency drive and remove the brake resistor.

This alarm/warning could also occur if the brake resistor overheats. Terminal 104 to 106 are available as brake resistor. Klixon inputs, see section Brake Resistor Temperature Switch.



Warning: There is a risk of substantial power being transmitted to the brake resistor if the brake transistor is short-circuited.

ALARM/WARNING 28, Brake check failed:

Brake resistor fault: the brake resistor is not connected/working.

ALARM 29, Drive overtemperature:

If the enclosure is IP 20 or IP 21/Type 1, the cut-out temperature of the heatsink is 203° F +5° F [95° C +5° C]. The temperature fault cannot be reset until the temperature of the heatsink is below 158° C +5° F [70° C +5° C].

The fault could be a result of:

- Ambient temperature too high
- Motor cable too long

ALARM 30, Motor phase U missing:

Motor phase U between the adjustable frequency drive and the motor is missing.

Turn off the adjustable frequency drive and check motor phase U.

ALARM 31, Motor phase V missing:

Motor phase V between the adjustable frequency drive and the motor is missing. Turn off the adjustable frequency drive and check motor phase V.

ALARM 32, Motor phase W missing:

Motor phase W between the adjustable frequency drive and the motor is missing. Turn off the adjustable frequency drive and check motor phase W.

ALARM 33, Soft-charge fault:

Too many power-ups have occurred within a short time period. See the chapter *General Specifications* for the allowed number of power-ups within one minute.

WARNING/ALARM 34, Serial communication bus fault:

The serial communication bus on the communication option card is not working.

WARNING/ALARM 36, Line failure:

This warning/alarm is only active if the supply voltage to the adjustable frequency drive is lost and parameter 14-10 is NOT set to OFF. Possible correction: check the fuses to the adjustable frequency drive

ALARM 38, Internal fault:

When this alarm sounds, it may be necessary to contact your Danfoss supplier. Some typical alarm messages:

0	The serial port cannot be initialized. Serious hardware failure
256	The power EEPROM data is defective or too old.
512	The control board EEPROM data is defective or too old.
513	Communication timeout Reading EEPROM data
514	Communication timeout Reading EEPROM data
515	The Application Orientated Control cannot recognize the EEPROM data.
516	Cannot write to the EEPROM because a write command is on progress
517	The write command has timed out.
518	Failure in the EEPROM
519	Missing or invalid barcode data in EEPROM 1024 – 1279 CAN telegram cannot be sent. (1027 indicates a possible hardware failure)
1281	Digital Signal Processor flash timeout
1282	Power micro software version mismatch
1283	Power EEPROM data version mismatch
1284	Cannot read Digital Signal Processor software version
1299	Option SW in slot A is too old.
1300	Option SW in slot B is too old.
1301	Option SW in slot C0 is too old.
1302	Option SW in slot C1 is too old.
1315	Option SW in slot A is not supported (not allowed).
1316	Option SW in slot B is not supported (not allowed).
1317	Option SW in slot C0 is not supported (not allowed).
1318	Option SW in slot C1 is not supported (not allowed).

1536	An exception in the Application Orientated Control is registered. Debug information written in LCP
1792	DSP watchdog is active. Debugging of power part data Motor Orientated Control not transferred correctly
2049	Power data restarted
2315	Missing SW version from power unit
2816	Stack overflow Control board module
2817	Scheduler slow tasks
2818	Fast tasks
2819	Parameter thread
2820	LCP stack overflow
2821	Serial port overflow
2822	USB port overflow
3072-5122	Parameter value is outside its limits. Perform an initialization. Parameter number causing the alarm: Subtract the code from 3072. Ex Error code 3238: 3238-3072 = 166 is outside the limit
5123	Option in slot A: Hardware incompatible with Control board hardware
5124	Option in slot B: Hardware incompatible with Control board hardware
5125	Option in slot C0: Hardware incompatible with Control board hardware
5126	Option in slot C1: Hardware incompatible with Control board hardware
5376-6231	Out of memory

WARNING 40, Overload of Digital Output Terminal 27:

Check the load connected to terminal 27 or remove short-circuit connection. Check parameters 5-00 and 5-01.

WARNING 41, Overload of Digital Output Terminal 29:

Check the load connected to terminal 29 or remove short-circuit connection. Check parameters 5-00 and 5-02.

WARNING 42, Overload of Digital Output On X30/6:

Check the load connected to X30/6 or remove short-circuit connection. Check parameter 5-32.

WARNING 42, Overload of Digital Output On X30/7:

Check the load connected to X30/7 or remove short-circuit connection. Check parameter 5-33.

WARNING 47, 24 V supply low:

The external 24 V DC backup power supply may be overloaded; otherwise, contact your Danfoss supplier.

WARNING 48, 1.8 V supply low:

Contact your Danfoss supplier.

WARNING 49, Speed limit:

The speed is not within the range specified in par. 4-11 and par. 4-13.

ALARM 50, AMA calibration failed:

Contact your Danfoss supplier.

ALARM 51, AMA check Unom and Inom:

The setting of motor voltage, motor current and motor power is presumably wrong. Check the settings.

ALARM 52, AMA low Inom:

The motor current is too low. Check the settings.

ALARM 53, AMA motor too big:

The motor is too big for the AMA to be carried out.

ALARM 54, AMA motor too small:

The motor is too big for the AMA to be carried out.

ALARM 55, AMA par. out of range:

The par. values found from the motor are outside the acceptable range.

ALARM 56, AMA interrupted by user:

The AMA has been interrupted by the user.

ALARM 57, AMA timeout:

Try to start the AMA again a number of times until it is carried out. Please note that repeated runs may heat the motor to a level where the resistances R_s and R_r are increased. In most cases, however, this is not critical.

ALARM 58, AMA internal fault:

Contact your Danfoss supplier.

WARNING 59, Current limit:

Contact your Danfoss supplier.

WARNING 61, Encoder loss:

Contact your Danfoss supplier.

WARNING 62, Output Frequency at Maximum Limit:

The output frequency is higher than the value set in par. 4-19.

ALARM 63, Mechanical Brake Low:

The actual motor current has not exceeded the "release brake" current within the "Start delay" time window.

WARNING 64, Voltage Limit:

The load and speed combinations demand a motor voltage higher than the actual DC link voltage.

WARNING/ALARM/TRIP 65, Control Card Overtemperature:

Control card overtemperature: The cut-out temperature of the control card is 176° F [80° C].

WARNING 66, Heatsink Temperature Low:

The heatsink temperature is measured at 32° F [0° C]. This may indicate that the temperature sensor is defective, and thus the fan speed is increased to the maximum if the power part or control card is very hot.

ALARM 67, Option Configuration has Changed:

One or more options has either been added or removed since the last power-down.

ALARM 68, Safe Stop Activated:

Safe Stop has been activated. To resume normal operation, apply 24 V DC to terminal 37, then send a reset signal (via bus, digital I/O, or by pressing [RESET]). For correct and safe use of the Safe Stop function, follow the related information and instructions in the Design Guide

ALARM 70, Illegal FC Configuration:

Current combination of control board and power board is illegal.

ALARM 80, Drive Initialized to Default Value:

Parameter settings are initialized to default setting after a manual (three-finger) reset.

ALARM 91, Analog Input 54 Wrong Settings:

Switch S202 has to be set in position OFF (voltage input) when a KTY sensor is connected to analog input terminal 54.

ALARM 250, New Spare Part:

The power or switch mode power supply has been exchanged. The adjustable frequency drive type code must be restored in the EEPROM. Select the correct type code in Par 14-23 according to the label on unit. Remember to select 'Save to EEPROM' to complete.

ALARM 251, New Type Code:

The adjustable frequency drive has a new type code.

Index

2

24 V Dc Backup	3
----------------------	---

A

Abbreviations	5
Access To Control Terminals	63
Airflow	30
Alarm Messages	127
Ama	71
Analog Inputs	112
Analog Output	113
Approvals	4
Automatic Motor Adaptation (ama)	70, 81

B

Back Cooling	31
Brake Cable	58
Brake Control	131
Brake Resistor Temperature Switch	63

C

Cable Length And Cross-section:	51
Cable Lengths And Cross-sections	115
Cable Positions	25
Cabling	50
Communication Option	133
Control Cable Routing	49
Control Cables	68
Control Cables	67
Control Card Performance	115
Control Card, +10 V Dc Output	114
Control Card, 24 V Dc Output	114
Control Card, Rs-485 Serial Communication	114
Control Card, Usb Serial Communication	114
Control Characteristics	115
Control Terminals	63
Cooling	30

D

Dc Link	131
Default Settings	83
Devicenet	3
Digital Inputs:	111
Digital Output	113
Disposal Instructions	7
Drip Shield Installation	36
Duct Cooling	31
Duct Kit Ordering Numbers	31
Duct Work Cooling Kits	36

E

Elcb Relays	56
Electrical Installation	63, 67
Etr	131
External Fan Supply	60

F

Floor Mounting	33
Fuses	60
Fusing	50

G

General Considerations	22
General Warning	8
Graphical Display	75
Ground Leakage Current	8
Grounding	55

I

Input Polarity Of Control Terminals	68
Installation Of 24 Volt External Dc Supply	50
Installation Of Rittal Enclosures	37
Installation On Pedestal	46
Installation On The Wall - Ip 21 (nema 1) And Ip 54 (nema 12) Units	32
Intermediate Circuit	131
It Line Power	56

K

Kit Contents	37
Kty Sensor	131

L

Language	78
Language Package 1	78
Language Package 2	78
Language Package 3	78
Language Package 4	78
Lcp	75
Lcp 101	76
Lcp 102	75
Leakage Current	9
Leds	75, 76
Lifting	15
Line Connection	59
Line Supply (L1, L2, L3)	111
Load Sharing	58
Local Control Panel	76

M

Main Reactance	81
Maximum Reference	82
Mct 10	3
Mechanical Brake Control	72
Mechanical Dimensions	20
Mechanical Dimensions	16
Mechanical Installation	22
Minimum Reference	82
Motor Cable	57
Motor Current	79
Motor Frequency	79
Motor Nameplate	70
Motor Nominal Speed, 1-25	79

Motor Output	111
Motor Overload Protection	8
Motor Power	79
Motor Protection	116
Motor Thermal Protection	73
Motor Voltage	79
Motor Voltage, 1-22	79
N	
Nameplate Data	70
Non-ul Compliance	62
Numerical Display	76
O	
Ordering	37
Output Performance (u, V, W)	111
P	
Parallel Connection Of Motors	73
Pedestal Installation	33
Planning The Installation Site	14
Potentiometer Reference	66
Power Connections	50
Product Specification	117
Profibus	3
Protection	60
Protection And Features	116
Pulse Start/stop	65
Pulse/encoder Inputs	113
R	
Ramp 1 Ramp-down Time	83
Ramp 1 Ramp-up Time	82
Rated Power	21
Receiving The Adjustable Frequency Drive	14
Relay Outputs	114
Repair Work	9
Required Tools:	46
Residual Current Device	9
Rfi Switch	56
S	
Safe Stop	10
Safe Stop Installation	11
Safety Category 3 (en 954-1)	11
Safety Instructions	8
Serial Communication	114
Serial Communication Bus Connection	49
Shielded Cables	57
Shielded/armored	68
Shielding Of Cables:	51
Sine-wave Filter	51
Space	22
Speed Up/slow	66
Start/stop	65
Stator Leakage Reactance	81
Status Messages	75
Stopping Category 0 (en 60204-1)	11

Surroundings	115
Switches S201, S202, And S801	69
Switching Frequency:	51
Symbols	4
T	
Terminal Locations	24, 26
Torque	56
Torque Characteristics	111
Torque For Terminals	57
U	
Unintended Start	9
Unpacking	14
V	
Voltage Level	111
Voltage Reference Via A Potentiometer	66
W	
Warnings	127
Wire Access	23



www.danfoss.com/drives

Danfoss shall not be responsible for any errors in catalogs, brochures or other printed material. Danfoss reserves the right to alter its products at any time without notice, provided that alterations to products already on order shall not require material changes in specifications previously agreed upon by Danfoss and the Purchaser. All trademarks in this material are property of the respective companies. Danfoss and the Danfoss logotype are trademarks of Danfoss A/S. All rights reserved.

For: Industrial Sales, Application Engineering

Danfoss Drives

Division of Danfoss Inc.
4401 N. Bell School Road
Loves Park, IL, 61111
Toll free: 800/432-6367
Telephone: 815/639-8600
Fax: 815/639-8000
www.namc.danfoss.com

For: HVAC Sales, Water Sales, Engineered Panels

Danfoss Graham and Danfoss US Water

Division of Danfoss Inc.
8800 W. Bradley Road
Milwaukee, WI, 53224
Toll free: 800/621-8806
Telephone: 414/355-8800
Fax: 414/355-6117
www.namc.danfoss.com

